

RTF428KNM-N/U

Communicating Fan Coil Thermostat

SPECIFICATION DATA



Specifications

Physical Layer	EIA485
Protocol	Modbus RTU
Baud rate	9600(Default)
Parity	None
Occupancy Mode	Yes
Remote Sensor Terminal	Support NTC10/ 20K
Error Checking Mechanism	CRC
Rated Power & Frequency	90~240VAC ±10%, 50/60Hz
Power consumption	<2W
Control	PI, On/off output
Accuracy	±0.5°C at 25°C
Auto Cycle times	100,000 times
Manual Cycle times	10,000 times
Protection class	IP20
Set point range	5 ~ 45°C
Display range	0 ~ 60°C
Ambient operating limits	0~ +49°C
Ambient storage limits	-30 ~ +60°C
Humidity limits	5~90% RH, non-condensing
Action Type:	1
Pollution Degree	2
Protection against electric shock class	For Class II application
Electronic control software class	Class A
Rated Impulse Voltage:	2500V
Maximum Temperature for Relay wiring	155°C
Wire Sectional area (Recommendation)	1.0~1.5mm ²
Applied altitude up to 2000m above sea level	
Rating Capacity	
Working current for the whole product	: 5(3)A
5A: When the load of the thermostat is resistance	
3A: When the load of the thermostat is inductance	
For Fan load 5(2)A	
5A:when the load is resistance; 2A:When the load is inductance	
For Valve load 2(1)A	
2A: when the load is resistance;1A: when the load is inductance	
The valve need have overtravel-limit organ to turn off the load.	

General

The RTF428KNM-N/U communicating thermostat is designed for 3-speed fan and valve control in a fan coil system, including:

- 2-pipe cool only/heat only/manual changeover
- 4-pipe cool/heat manual/automatic changeover
- Ventilation mode
- Manual or automatic 3 speed fan control
- Water valve on/off control

The RTF428KNM-N/U is available in Modbus RTU protocol and can be easily integrated into building automation system.

Features

- RS485 interface in Modbus RTU slave mode
- Memorized time off
- Random startup
- LCD display with simple user interface
- Soundless keypad
- Configurable dual inputs for occupancy mode
- Manual or automatic fan speed selectable
- User setting can be stored when power loss
- Freeze protection function available
- Keypad lock options
- Preset fan speed configuration in occupancy mode
- Configurable dual inputs for occupancy mode
- Room temperature or set point temperature display available

Model Selection

Model Number	Backlight	Application	Power Supply	Ventilation Mode	Energy Saving Mode
RTF428KNM-N/U	White	2/4 pipe FCU	220/230Vac; 50/60Hz	Y	Y

Product Design

Thermostat appearance

Dimensions (mm)

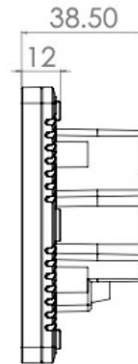
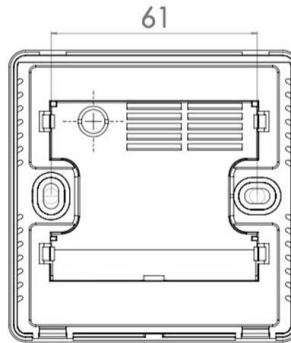
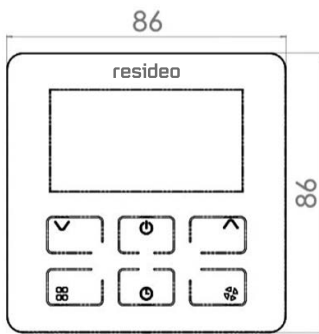

LCD display

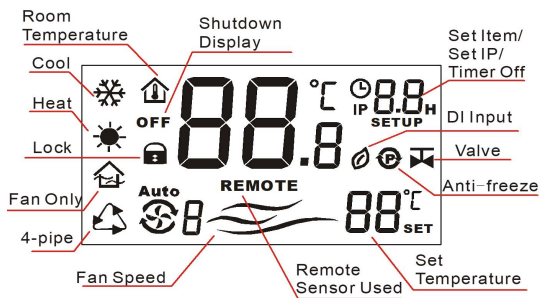

Function

Valve Control

Thermostat measures the room temperature via integrated sensor and maintains the setpoint by delivering on/off valve control command outputs.

The fan setting can be selected as manual or automatic 3 speed operation. When in "manual" mode, the fan is switched to the selected speed via control output FH (high), FM (Medium) , FL (Low).

While in "automatic" mode, fan speed depends on the difference between room temperature and setpoint. When room temperature reaches the setpoint, the valve will be closed, and the fan will be closed in the meanwhile.

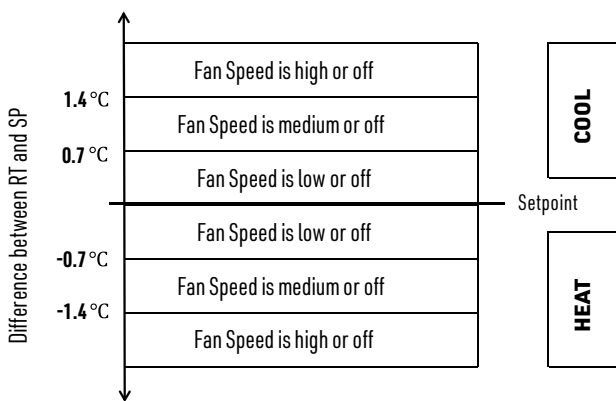
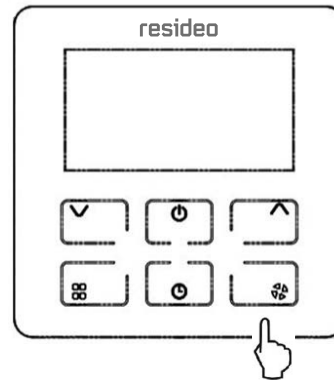
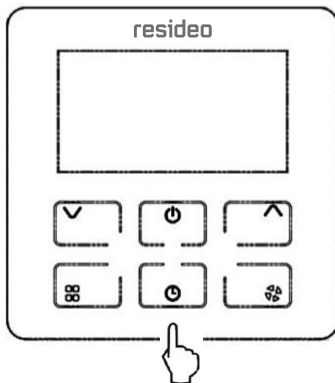

Fig. 1. Fan Speed Ramping Control Algorithm

Memorized Time Off

The time off feature will automatically turn off the thermostat after a selectable amount of time. To change the time setting, press the clock button for time adjustment.

NOTE: The setting range is from 0 to 12 hours. The step is 1 hour and the default value is 0.



Backlight

To turn on the backlight, press any key. The backlight will timeout 8 seconds after the last key is pressed. When in ISU and Installation test mode, the backlight will timeout 60 seconds after the last key is pressed.

Keypad Lockout

Keypad lockout can be set in ISU or over Modbus. The default status is "all keys available". Press "UP" and "DOWN" key together to activate keypad lockout.

Temperature Display

The room temperature set point temperature are display on the screen.

Operating Mode

Comfort Mode

In comfort mode, the setpoint and fan speed can be changed by pressing corresponding buttons. Comfort mode including 2-pipe cool only/heat only/manual changeover and 4-pipe manual /auto changeover applications.

Energy Saving Mode

Energy saving mode can be activated over Modbus.

If energy saving mode is activated over Modbus, then all keys will be locked to prevent the individual control on site. When disable the energy saving mode over Modbus, all keys will be available.

The setpoint will change to the energy saving heating/cooling setpoint when the energy saving mode is enabled.

Ventilation Mode

Press "function" button to enter "ventilation" mode. In "ventilation" mode, no output for valve while the fan will operate at selected fan speed.

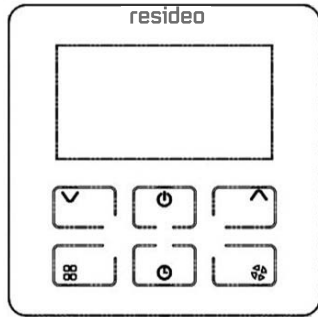

Freeze Protection Mode

Freeze protection can be selected as disabled or enabled (default) in the ISU or over Modbus. In freeze protection mode only in heating applications), when thermostat is off and the temperature is below 5°C, the thermostat will activate heating mode until the temperature rises to 7°C.

Installation and Wiring

RTF428KNM-N/U can be installed in standard 86 size junction box directly.



The screws must be locked tightly to avoid wire break off from the terminals.
The temperature of mounting box and wall should be in the operating temperature range.

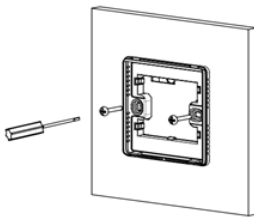

1

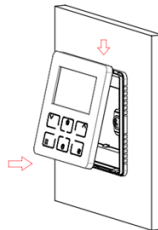

2

Wiring Diagram

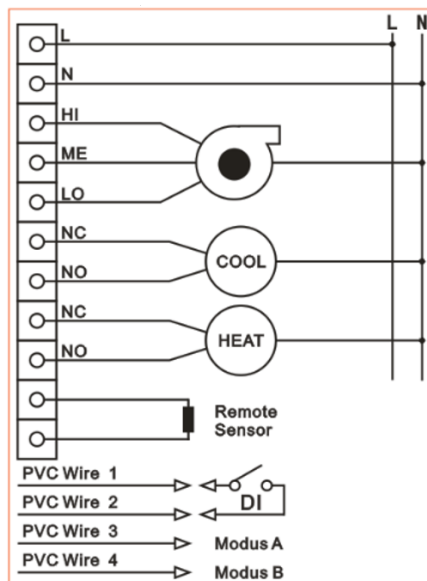

ISU (Installation Setup)

Press and hold the "mode" and "up" buttons together for more than 3 seconds to enter or exit ISU. Change the ISU code by pressing the "mode" button and then change the option setting by pressing the "up" and "down" button refer to the following introduction.

ISU Code	Description	Default	ISU Code	Description	Default
0	Modbus address: Range: 01~31; Step:1	1	8	Fan Operation 1: Stop the Fan when Temp. Set point is achieved 0: Never Stop the Fan	0
1	Set Temp. upper limit Range:(5~45°C); Step:1°C	30°C	9	(Cooling) energy-saving Temp. Range:(25~30°C) Step:1°C	25
2	Set temp. low limit Range:(5~45°C); Step: 1°C	10°C	10	(Heating) energy-saving Temp. Range:(25~30°C) Step:1°C	15
3	Display Temp. Adjustment (offset) Range: (-5 ~ 5°C); Step: 1°C	0°C	11	DI (Digital Input): 0: Energy saving 1: Remote on/off	0
4	Diff Temp. Adjustment (offset) Range: (1 ~ 5°C); Step: 1°C	1°C	12	DI ECO Fan Speed : 0: Low 1: Mid 2: High 3: Auto	3
5	Power Recovery Status: 0: Off Status 1: On Status 2: Last Status	0	13	Valves 0: Four pipe 1: Two Pipe	0
6	Power off Show : 0: No content displayed 1: Room Temp.& "OFF"	1	14	Power supply linkage 0: Off 1: On	0
7	Sensor : 0: Built-in sensor 1: Remote sensor 10K 2: Remote sensor 20K	0	15	0: No anti-freeze 1: With anti-freeze	0

Modbus Address Table

When the thermostat is integrated into building automation system. Please make configuration refer below list.

Address Registers	Parameters	Properties and Value	Properties	Address Registers	Parameters	Properties and Value	Properties
1	Thermostat Status	0: On 1: Off	R/W	10	Set upper temp limit	Set temperature value 50~450 (5.0°C~45.0°C)	R/W
2	Room Temp.	100~300 (10.0°C~30.0°C)	R	11	Set lower temp limit	Set temperature value 50~450 (5.0°C~45.0°C)	R/W
3	Set Temp.	Set temperature value 100~300 (10.0°C~30.0°C)	R/W	12	lock & unlock	0: unlock 1: lock	R/W
4	Fan Status	1: Low 2: Med 3: High 4: Auto High 5: Auto Med 6: Auto Low 7: Auto Stop	R/W	13	DI Function	0: Energy saving 1: Remote n/off	R/W
5	System mode	0: Ventilation 1: Heat 2: Cool	R/W	14	DI Status	0: Short 1: Open	R
6	Valve1 status	0: valve Off 1: valve on	R	15	ECO Fan speed	0: Low 1: Med 2: High 3: Auto	R/W
7	Power Recovery status	0: Off Status 1: On Status 2: Last Status	R/W	16	Delay off time	0~12	R/W
8	Valve2 status	0: valve Off 1: valve on	R	17	Remain time to turn off	0~12	R
9	Temp calibration setting	Low byte: 0~50 (+0.0°C~5.0°C) 255~206 (-0.1°C~-5.0°C) High byte: 0x00	R/W				



Products & Solutions
Resideo Singapore Pte.Ltd
#04-01, 1 Paya Lebar Link
Paya Lebar Quarter 1
Singapore 408533
Subject to change without notice.