

RT6800 Series Digital Thermostat

2-pipe fan coil control

DATA SHEET



Application

RT6800 digital thermostats are designed for application of 3-speed fan and valves in 2-pipe fan coil system.

Including:

2-pipe cool only/heat only/manual changeover between heat and cool

Ventilation mode

Manual or automatic 3-speed fan control

Water valve control

Fan speed can be selected to automatic or manual 3-speed control mode.

In ventilation mode, fan only support manual speed control.

Features

- Super modern appearance design, suitable for office, hotel and residential building
- Horizontal and vertical model available for variant application
- Slim design, direct installation on 86 size box
- Big LCD with English and icon display
- Easy to install and set-up
- Selectable room temperature or setpoint temperature display
- Manual or automatic fan speed selection by button press
- Remote temperature sensor
- Energy saving mode activation by button press or dry contact (key card)
- Cycle per Hour (CPH) function
- Adjustment of display room temperature
- Temperature unit either °C or °F
- User setting can be kept when power off
- Freezing protection function available
- Lock or unlock keys or part of keys in Installer Set-up
- Heat and cool setpoint limitation for energy saving

Model Summary

Model	Horizontal/ Vertical	2-pipe/ 4-pipe	Operating Voltage(Vac)	Energy Saving	Ventilation	Manual/ Automatic Fan	Remote Sensor
RT6800H2WN	Horizontal	2	220/230	Y	Y	Y	Y
RT6800V2WN	Vertical	2	220/230	Y	Y	Y	Y

Mechanical Design

Thermostat appearance



LCD display

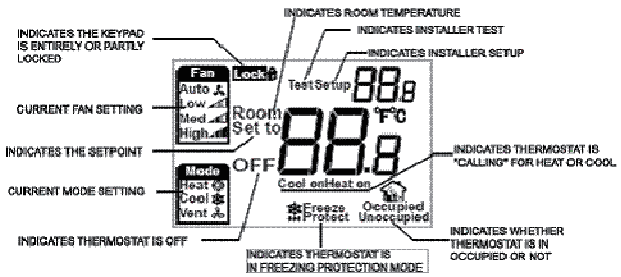

Function

Valve control

Thermostat acquires the room temperature via its integrated sensor or external temperature sensor and maintains the setpoint by delivering on/off valve control commands output.



PRESS THE MODE BUTTON TO SELECT HEAT, COOL OR VENT

Fan Operation



PRESS THE FAN BUTTON TO SELECT LOW, MED, HIGH OR AUTO

Fan can be selected as manual or automatic 3-speed operation. In Manual mode, the fan is switched to the selected speed via control output Gh, Gm, Gl. While in automatic mode, fan speed depends on the difference between room temperature and setpoint. When room temperature reaches setpoint, valve will be closed and meanwhile, fan will be closed either.

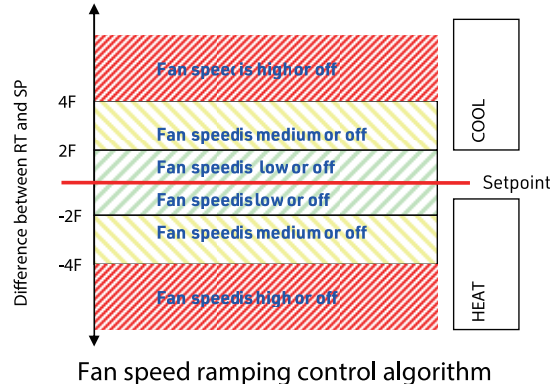

Temperature display

The displayed temperature can be set to acquired room temperature or setpoint. The setting can be made during Installer Set-Up process.

Cycle per hour (CPH)

In order to get a more accurate temperature control, CPH function may enable the thermostat to open the valve for several times per hour even the temperature is close to setpoint (difference less than 1/2 P-band). The default value is 4 for heating and 3 for cooling and can be changed in Installer Set-Up process.

Remote temperature sensor

RT6800 provides control either depending on the acquired room temperature or depends on the return air temperature

Keypad lock

Keypad lock can be set in ISU with default status is all keys available. You may change into mode button locked out, Fan and mode buttons locked out and All buttons locked out by changing the ISU.

Operating modes

The following operating modes are available:

Comfort mode

In comfort mode, the setpoint can be changed by pressing up and down button. Different applications include cool only, heat only and manual heat/cool changeover.

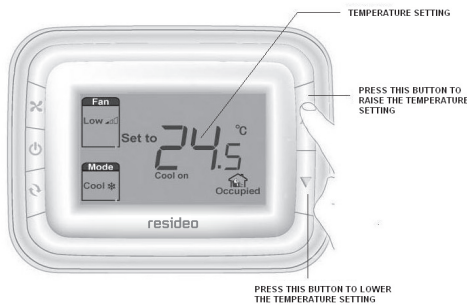

Ventilation mode

Press mode button to enter ventilation mode. In ventilation mode, no output for valve while the fan will operate according to selected fan speed.

Energy saving mode

A potential-free dry contact (such as hotel key card) or button press (pressing mode button for continuous 3 seconds) can activate the energy saving mode with  icon appearing on screen. The dry contact can be selected as normal open or normal close type in ISU.

If activated by dry contact, all buttons will be locked except the multi-key for ISU. If energy saving by button press, then any following button press will stop energy saving mode.

For heating mode, if the energy saving function is enabled, the setpoint will change to remote setback heating setpoint. The range of remote setback heating setpoint is from 10°C to 21°C and default value is 18°C. The value may change in ISU with step of 0.5°C.

For cooling mode, if the energy saving function is enabled, the setpoint will change to remote setback cooling setpoint. The range of remote setback cooling setpoint is from 22°C to 32°C and default value is 26°C. The value may change in ISU with step of 0.5°C.



Freezing protection mode

Freezing protection can be selected as disabled (default) or enabled. In freezing protection mode (no such mode in cool only application), when thermostat is in OFF mode while the acquired temperature is below 6°C, the thermostat will start heat mode until the temperature rises to 8°C or the thermostat is turned on.



On/off mode

Pressing power button can switch between on and off mode.



Technical specification

Power supply	230(+10%, -15%)VAC
Frequency	50/60Hz
Control algorithm	PI, On/off output
Accuracy	+/-1°C at 21°C
Rating capacity	For 220V power supply: 4(2)A for fan load, 2(1)A for zone valve
Cycle times	100,000 times
Setpoint range	10~32°C
Display range	0~37°C
Installation	Installed on 86x86mm junction box or US2x4 inch.
Protection Class	IP20
Environmental Conditions	
Operation temperature	-18~49°C
Shipping temperature	-35~65°C
Relative humidity	5~90%

Terminal Designations

Item	Terminal	Description
1	L	AC Power
2	Ch/Cc	Heating close/Cooling close
3	W/Y	Heating open/Cooling open
4	N	AC Ground
5	Gh	High speed fan relay
6	Gm	Medium speed fan relay
7	Gl	Low speed fan relay
8	Sc	Ground for remote sensor and remote setback
9	RSB	Remote set back
10	Rs	Remote sensor

Application 2: 2 pipes Cool only wiring diagram

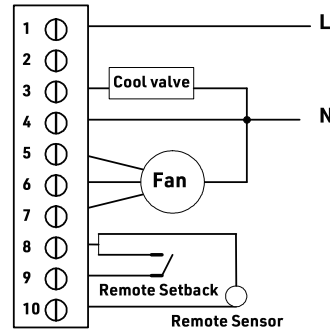

Typical wiring for ON/OFF control in 2 pipe cooling only (RVC4013)

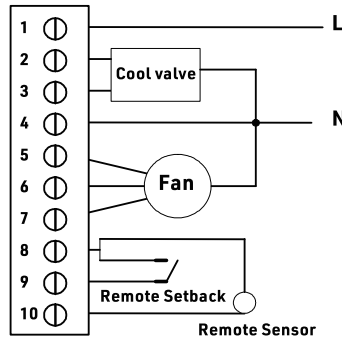

Typical wiring for 3-wire control in 2 pipe cooling only (RVN6013)

Wiring diagrams

Application 1: 2 pipes heat only wiring diagram

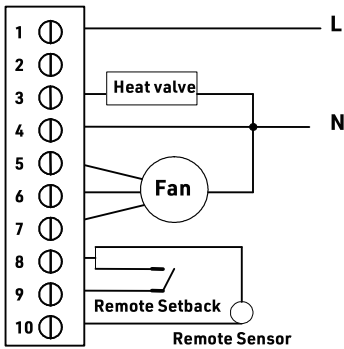

Typical wiring for ON/OFF control in 2 pipe heating only (RVC4013)

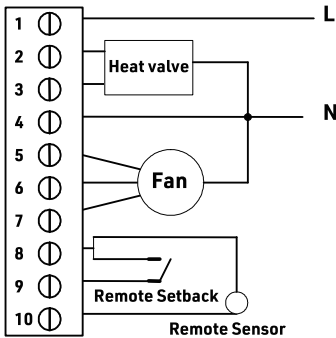

Typical wiring for 3-wire control in 2 pipe heating only (RVN6013)

Application 3: 2 pipes 1 stage Heat or 1 stage Cool MCO wiring diagram

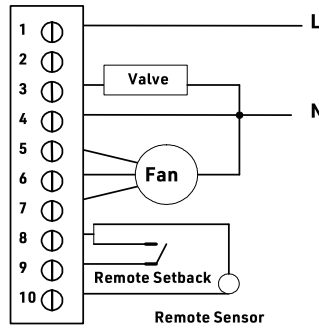

Typical wiring for ON/OFF control in 2 pipes 1H1C (RVC4013)

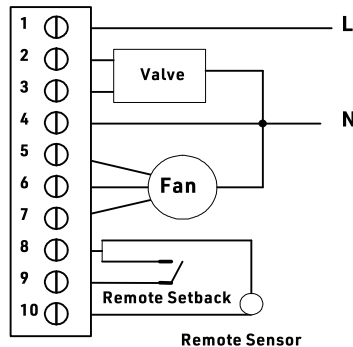

Typical wiring for 3-wire control in 2 pipes 1H1C (RVN6013)

Installation & Commissioning

Install the thermostat about 5 feet (1.5m) above the floor in an area with good air circulation at average temperature.

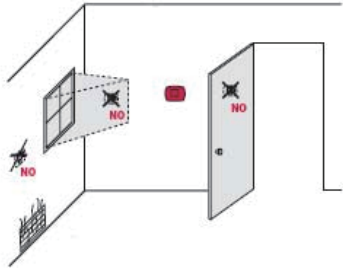

Do not install in locations where the thermostat can be affected by:

- Drafts or dead spots behind doors and in corners
- Hot or cold air from ducts
- Sunlight or radiant heat from appliances
- Concealed pipes or chimneys
- Unheated/uncooled areas such as an outside wall

Wiring

Pull wires through wire hole. Loosen screw terminals, insert wires into terminal block, then retighten screws.

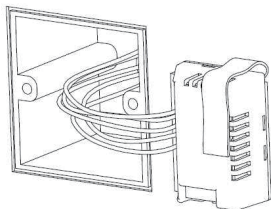

Push the Power box into the junction box.

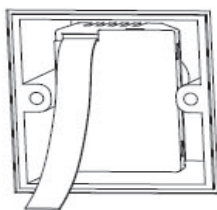

Place Back cover over junction box, insert and tighten mounting screws.

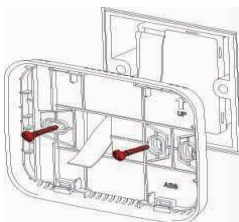

Insert the cable into connector on circuit board of thermostat.

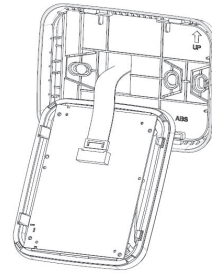

Align the 4 tabs on the Back cover with corresponding slots on the back of the thermostat, and then push it until the thermostat snaps in place.

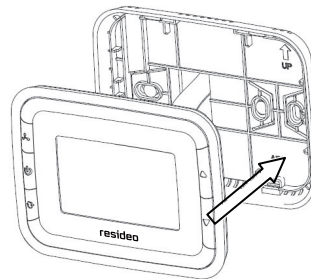

Installer Set-Up (ISU) setting

Press ▲ and ↻ simultaneously for 3 seconds to enter ISU as below:

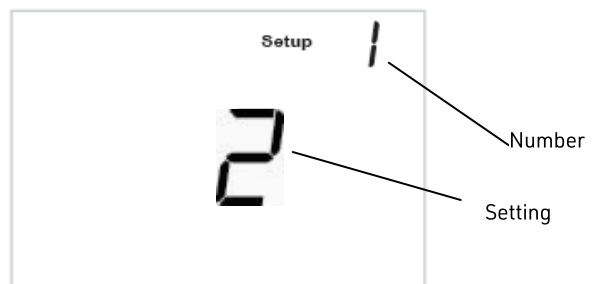

Press ▲ or ▼ to change settings

Press ↻ to advance to next function

Press and hold ▲ and ↻ buttons 3 seconds to exit and save settings

Setup Function Settings & Options

Number	Description	Possible Options
1	System type	0 Heat only
		1 Cool only
		2 Two pipes 1H1C manual(Default)
5	Remote sensor	0 Onboard sensor (Default)
		1 Remote sensor, NTC20K
9	Temperature scale	0 °F
		1 °C(Default)
10	Fan control type	0 Cycle only
		1 Constant only (3 speed: Low->Med->High-> Low)
		2 User can choose Cycle or Constant (3 speed: Low->Med->High->Auto->Low)(Default)
13	CPH value for heating	1
		2
		3
		4 (Default)
		5
		6
		7
		8
		9
		10
		11
		12
14	CPH value for cooling	1
		2
		3(Default)
		4
		5
		6
18	Display temperature adjustment	-2 °C (-4 °F)
		-1.5 °C (-3 °F)
		-1 °C (-2 °F)
		-0.5 °C (-1 °F)
		0 °C(0 °F) (Default)
		0.5 °C (1 °F)
		1 °C (2 °F)
		1.5 °C (3 °F)
2 °C (4 °F)		
19	Temperature display mode	0 Display room temperature
		1 Display setpoint
		2 Display both (Default)
20	Heating range stops	10-32 °C Default 32 °C (50-90 °F Default 90°F)
21	Cooling range stops	10-32 °C Default 10 °C (50-90 °F Default 50°F)

22	Keypad lockout	0 All keys available (Default)
		1 Mode button Locked out
		2 Fan and Mode buttons locked out
		3 All buttons locked out
23	Remote setback enable method	0 Hotel card NO
		1 Hotel card NC 2 Button (Default)
24	Remote setback heating setpoint	Range 10-21°C Default: 18 °C (Range 50-70°F Default: 64)
25	Remote setback cooling setpoint	Range 22-32°C Default: 26 °C (Range 72-90 °F Default: 79 °F)
27	Freeze protection	0 Disabled (Default)
		1 Enabled

Installer system test

After completing the installer setup above, press the button again to begin a system test.

Follow the procedure below to test the heating and cooling and fan system.

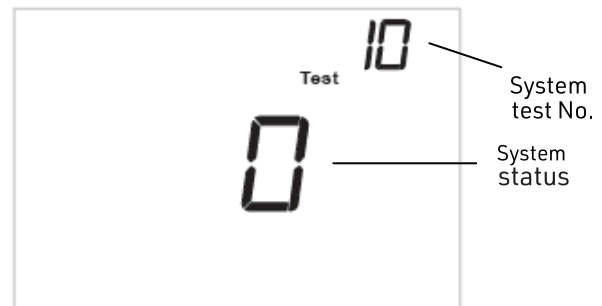

Press and hold ▲ and ▼ buttons 3 seconds to enter test mode.

Press ▲ or ▼ button to change system status.

Press ↻ button to advance to next test number.

Press ▲ and ▼ button hold to terminate system test at any time.

System Test System Status

10 Heat 0 Heat turn off.
1 Heat turns on.

30 Cool 0 Cool off.
1 Cool on.

40 Fan 0 Fan off
1 Low speed Fan on
2 Medium speed Fan on
3 High speed Fan on

- 70 Thermostat information (for reference only)
- 71 Software revision number (major revisions)
- 72 Software revision number (minor revisions)
- 73 Configuration identification code (major)
- 74 Configuration identification code (minor)
- 75 Production configuration date code (week)
- 76 Production configuration date code (year)

Troubleshooting Tips

If...	Then...
Heating system does not turn on.	<ul style="list-style-type: none"> • Set the mode to Heat by pressing the Mode button. • Check that the heat temperature setting is set above the room temperature and "Heat On" shows solidly in the display. • Wait five minutes for the heating system to respond.
Cooling system does not turn on.	<ul style="list-style-type: none"> • Set the mode to Cool by pressing the Mode button. • Check that the cool temperature setting is set below the room temperature and "Cool On" shows solidly in the display. • Wait five minutes for the cooling system to respond.
The fan doesn't work.	<ul style="list-style-type: none"> • Check whether the Fan mode is set to Auto • Check whether the heating or cooling system works well.
The Mode button doesn't work.	<ul style="list-style-type: none"> • Check whether the keypad is locked or not. • Check whether the system is working in Energy saving mode. • Check whether the thermostat is off.

The Fan button doesn't work.	<ul style="list-style-type: none"> • Check whether the keypad is locked or not. • Check whether the system is working in Energy saving mode. • Check whether the thermostat is off.
The Up or Down button doesn't work.	<ul style="list-style-type: none"> • Check whether the keypad is locked or not. • Check whether the system is working in Energy saving mode. • Check whether the thermostat is off.

Dimension

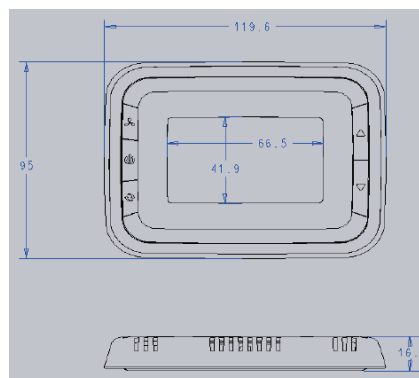

Products & Solutions
Resideo Singapore Pte.Ltd
#04-01, 1 Paya Lebar Link

Paya Lebar Quarter 1
Singapore 408533

Subject to change without notice.

Pittway Sarl, Z.A. La Pièce 4, 1180 Rolle, Switzerland

Country of origin: China

©2021 Resideo Technologies, Inc.
All rights reserved.