

**Honeywell**



# MAXON Series 8000 Pneumatic Shut-off Valves

TECHNICAL CATALOG



32M-05003-03

## Table of contents

<b>MAXON Series 8000 Pneumatic Shut-off Valves</b> .....	<b>1</b>
<b>PRODUCT OVERVIEW</b> .....	<b>3</b>
<b>FEATURES &amp; BENEFITS</b> .....	<b>3</b>
Body styles .....	4
Valve body material and trim selections .....	4
Fire safe valves .....	5
<b>AGENCY APPROVALS AND CERTIFICATIONS</b> .....	<b>6</b>
<b>VALVE MODEL NUMBER DESCRIPTION</b> .....	<b>8</b>
Options and accessories .....	9
<b>VALVE BODY ASSEMBLY SPECIFICATIONS</b> .....	<b>12</b>
<b>VALVE BODY ASSEMBLY – COMMON GAS COMPATIBILITY</b> .....	<b>13</b>
<b>VALVE ACTUATOR ASSEMBLY SPECIFICATIONS</b> ...	<b>14</b>
<b>ELECTRICAL DATA</b> .....	<b>15</b>
General Purpose – Series 8011, 8111, 8021 & 8121 ...	16
Non-incendive Valves – Series 8012, 8112, 8022 & 8122 .....	16
<b>DIMENSIONS &amp; WEIGHTS</b> .....	<b>20</b>
Series 8100 valve bodies: .75” (DN20) to 3” (DN80) ...	20
Series 8100 actuator: .75” (DN20) to 3” (DN80) .....	21
Series 8000 valve body: 2.5” CP (DN65), 3” CP (DN80), 4” CP (DN100) .....	22
Series 8000 actuator: 2.5” CP (DN65), 3” CP (DN80), 4” CP (DN100) .....	23
Series 8100 valve body: 2.5” CP, 3” CP, 4” CP .....	24
Series 8100 actuator: 2.5” CP, 3” CP, 4” CP .....	25
Series 8000 and 8100: 6” and 8” .....	26
<b>ACCESSORIES</b> .....	<b>27</b>
<b>INSTALLATION, OPERATION AND MAINTENANCE INSTRUCTIONS</b> .....	<b>30</b>
Component identification .....	31
Installation .....	31
<b>AGENCY APPROVALS AND CERTIFICATIONS</b> .....	<b>36</b>
<b>ELECTRICAL DATA</b> .....	<b>38</b>
Normally-Closed Shut-Off Valves .....	38
Normally-Open Vent Valves .....	40
<b>OPERATING INSTRUCTIONS</b> .....	<b>42</b>
<b>MAINTENANCE INSTRUCTIONS</b> .....	<b>45</b>
Solenoid replacement procedure .....	46
Actuator assembly rotation/replacement .....	48
Field installation of valve position switch .....	49
<b>IEC 61508 INSTRUCTION REQUIREMENTS</b> .....	<b>51</b>
<b>FITTING CERTIFICATE</b> .....	<b>52</b>

## PRODUCT OVERVIEW

- **Pneumatically actuated valves** safety shutoff or vent
- **Compact design** with internally mounted solenoid, quick exhaust and position switches (that are protected from the environment) simplify piping and minimize space requirements
- **FM, CSA, CE, IECEX, INMETRO KC, CCC, and UKCA marked** industrial valves
- **Hazardous Location approved:** Intrinsically Safe (ia) and Non-Incendive (nA) constructions available
- Full assessment to IEC 61508 as **SIL 3 capable**
- **Large top mounted 360-degree open-shut visual position indicator**, configurable in red/green or yellow/black color schemes
- **Cast iron, carbon steel, low temperature carbon steel and stainless steel body assemblies** with internal trim options to handle general purpose or corrosive gases; oxygen compatibility, NACE compliance, and fire safe conformance to API 6FA
- **Ambient temperature ranges** of -58°F (-50°C) to 140°F (60°C); Gas temperature range of -58°F (-50°C) to 212°F (100°C)
- **Metal to metal seals** meet Fluid Control Institute (FCI) 70-2 control valve standard for Class VI seat leakage

## FEATURES & BENEFITS

**MAXON Series 8000 Pneumatic Safety Shut-off Valves** are a Valve and Actuator combination that are purposely designed together. No mix and match components that are adapted to fit together.

**The valve's quick exhaust and powerful spring** provide valve closure in less than one second and reliable, long-life operation.

**The field-replaceable actuator** provides easier maintenance and reduced downtime. The actuator can also be rotated around the valve body in 90° increments to fit your specific application requirements.

**A unique bonnet design** eliminates packing adjustments for reduced maintenance and minimized drag on closing.

**The large top-mounted open-shut indicator** is visible from all angles for easy proof of valve position. SIL 3 capable design provides easy design for safety instrumented systems in the IEC 61508 and 61511 process. FM, CSA and CE approvals for use as a fuel safety shut-off valve making easy integration with worldwide certifications.

**MAXON offers MAXON PSCheck partial stroke test technology** designed especially for Series 8000 valves,

to minimize probability of failure on demand by testing valve function without line shutdown. The combination of MAXON PSCheck and SIL 3 capable Series 8000 valves will help ensure safe, reliable operation of your process.

**Replacement Actuator assemblies** are available in 120VAC 50/60 Hz, 240VAC 50/60 Hz, and 24VDC (with low power option), rated for NEMA 4, NEMA 4X and IP65.

Option available to utilize customer-supplied, externally mounted solenoids. When used in hazardous locations, the component must be rated for the Class and Division of the hazardous area.

Option available for speed control for adjustment of actuation speed.

Option available for manual reset (a control mounted on the valve must be physically reset for valve to actuate—but will then operate normally until tripped).

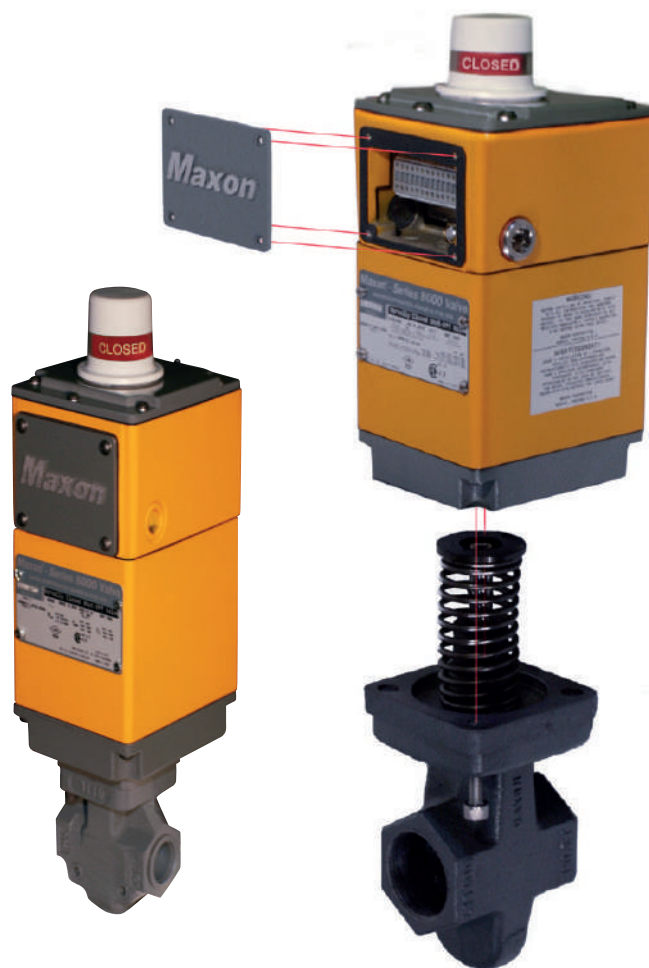

## Body styles

**Normally-closed shut-off valves** use instrument air to open quickly. Removal of electrical signal allows release of control air through solenoid and quick exhaust valve allowing the powerful closing spring in the Series 8000 Valve to close the valve in less than one second.

**Series 8011, 8012 & 8013**

requires 40-100 psig instrument air

**Series 8111, 8112 & 8113**

requires 65-100 psig instrument air

**Normally-open vent valves** use instrument air to close the valve quickly. Removal of electrical signal allows release of control air through solenoid and quick exhaust valve allowing the Series 8000 Valve to open in less than one second.

**Series 8021, 8022 & 8023**

requires 45-100 psig instrument air

**Series 8121, 8122 & 8123**

requires 70-100 psig instrument air



## Valve body material and trim selections

Cast iron, carbon steel and stainless steel body assemblies feature metal-to-metal seating that meets the FCI 70-2 control valve standard for Class VI seat leakage. Various trim options are available depending on the fuel gas used in your application. Industrial trim options are available with cast iron, stainless steel and PEEK wetted materials for corrosive fuels that may contain H<sub>2</sub>S and/or CO<sub>2</sub>, or other aggressive gases.

Options also available which meet NACE MR0175 requirements. Contact MAXON with your specific application details.

Valve bodies are available in your choice of threaded, flanged, and socket-welded connections. Bodies are currently available in 3/4" (DN20) through 8" (DN200) sizes. MAXON valve bodies are designed in accordance with many ASME/ANSI piping and valve standards. While no single ASME/ANSI specification covers our valve line in its entirety, our valve pipe connections comply with the applicable standard(s) listed below.

• NPT threaded connections (end connections, test connections)	ASME/ANSI B.1.20.2
• Cast iron valve flanged ends (125# Class end connections)	ASME/ANSI B.16.1
• Cast iron valve threaded connections (end connections)	ASME/ANSI B.16.4
• Steel & stainless steel valve flanged ends (Class 150# ends)	ASME/ANSI B.16.5
• Face-to-face and end-to-end dimensions	ASME/ANSI B.16.10
• Flanged facings	MSS SP-6
• Valve body wall thickness	ASME/ANSI B16.34

## Fire safe valves

Fire safe valves are offered with carbon steel and stainless steel body and bonnet materials. Fire safe trim options feature a stainless steel seat, disc and follower, preserving the high quality MAXON metal-to-metal seating and providing tight shut-off according to FCI 70-2 Class VI seat leakage requirements. A fire safe trim option is also available for those applications which also necessitate NACE MR0175 compliance. All fire safe trims include graphite packing which provides a redundant stem seal to prevent leakage in case of extreme heat from a fire. The graphite packing used in fire safe trims is maintenance-free and requires no adjustment, allowing for the long life and reliability inherent to MAXON valves. MAXON fire safe design is validated against API 6FA requirements.

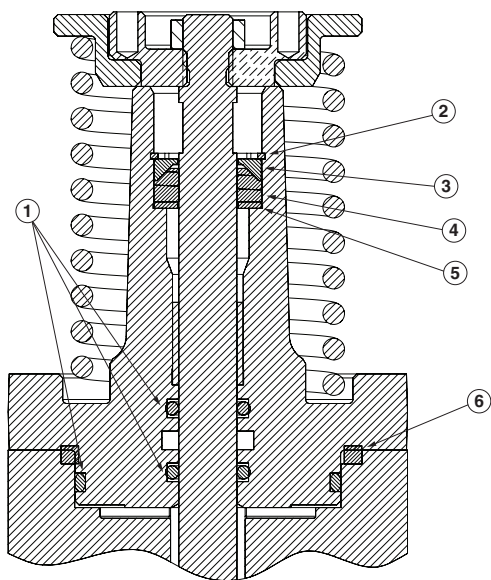

1)	O-rings
2)	Retaining ring
3)	Packing washer
4)	Graphoil stem ring
5)	Flat washer
6)	Graphoil body-to-bonnet ring











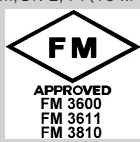









## Valve cycle requirements





This is based on the standards that MAXON valves are approved to and the corresponding minimum number of cycles to be completed without failure as shown in the chart.

	CSA (CSA 6.5)	FM (FM 7400)	European (EN161)
Automatic - Normally Closed Series 8011, 8111, 8012, 8112, 8013, 8113	100,000	20,000	<= 1" 200,000 <= 3" 100,000 <= 8" 50,000
Vent Valves Series 8021, 8121, 8022, 8122, 8023, 8123	No special requirements	No special requirements	No special requirements

## AGENCY APPROVALS AND CERTIFICATIONS

(Will vary with specific options selected)

	General Purpose Valves 8111, 8121, 8011, 8021 Series		Non-Incendive/Non-Sparking Valves 8112, 8122, 8012, 8022 Series		Intrinsically Safe Valves 8113, 8123, 8013, 8023 Series	
	Standards	Markings	Standards	Markings	Standards	Markings
FM Approvals	FM 7400		FM 3611 FM 3600 FM 3810 NEMA 250 IIEC 60529	Class I, Div 2, Groups ABCD, T4 (T5 w/ IS coil) Class II, Div 2, Groups FG, T4 (T5 w/ IS coil) Class III, Div 2, T4 (T5 w/ IS coil) 	FM 3610 FM 3600 FM 3810 NEMA 250 IIEC 60529	Class I, Div 1, Groups ABCD, T5 Class II, Div 1, Groups EFG, T5 Class III, Div 1, T5 
CSA/SIRA Approvals-IECEX Certification	Not Applicable	None	IEC 60079-0 IEC 60079-15 IEC 60079-31	IECEX SIR 19.0017X Ex nA nC IIC T4 Gc (T5 w/ IS coil) -40°C ≤ Ta ≤ 60°C (50°C max w/ IS coil) Ex tc IIIC T135°C Dc IP65	IEC 60079-0 IEC 60079-11	IECEX SIR 19.0017X Ex ia IIC T5 Gb Ex tc IIIC T135°C Dc -50°C ≤ Ta ≤ 50°C
CSA International	CSA 6.5 - 2015	 	CSA Std. C22.2: No. 0-M91 No. 25-1966 No. 94-M91 No. 213-M1987 CAN/CSA-E60079-0 CAN/CSA-E60079-15 IEC 60529	Class I, Div 2, Groups ABCD, T4 Class II, Div 2, Groups FG, T4 Class III, Div 2, T4 Ex nA IIC T4 Ta = 60C (w/ std coil) Ex nA IIC T5 Ta = 50C (w/ IS coil) (Zone 2 approval)  	CSA Std. C22.2: No. 0-M91 No. 25-1966 No. 94-M91 No. 157-M1992 CAN/CSA-E60079-0 CAN/CSA-E60079-11 IEC 60529	Class I, Div 1, Groups ABCD, T5 Class II, Div 1, Groups EFG, T5 Class III, Div 1, T5 Ex ia IIC T5, -50°C ≤ Ta ≤ 50°C (Zone 0 Approval)  
United Kingdom GAR, LVD Compliance <sup>1</sup>	BS EN 161 BS EN 13774		BS EN 161 BS EN 13774		BS EN 161 BS EN 13774	
European GAR, LVD Compliance <sup>1</sup>	EN 161 EN 13774		EN 161 EN 13774		EN 161 EN 13774	
United Kingdom Approvals (Hazardous Locations) <sup>2</sup>	Not Applicable	None	Not Applicable	None	BS EN 60079-0 BS EN 60079-11 BS EN 60529+A1 BS EN 13463-1 BS EN 13463-5	Sira 19ATEX2040X II 2GD Ex ia IIC T5 Gb Ex ia IIIC T100°C Db Ta = -50°C to +50°C IP65  
European Approvals (Hazardous Locations) <sup>2</sup>	Not Applicable	None	Not Applicable	None	EN 60079-0 EN 60079-11 EN 60529+A1 EN 13463-1 EN 13463-5	Sira 19ATEX2040X II 2GD Ex ia IIC T5 Gb Ex ia IIIC T100°C Db Ta = -50°C to +50°C IP65  
United Kingdom PED Compliance <sup>1</sup>						
European PED Compliance <sup>1</sup>						
IEC Approvals	IEC 61010-1 IEC 61508	None	IEC 61010-1 IEC 61508	None	IEC 61010-1 IEC 61508	None
NCC/Inmetro	Not Applicable	None	ABNT NBR: IEC 60079-0 IEC 60079-15 IEC 60079-31	Ex nA nC IIC T4 Gc (T5 w/ I.S. Coil) Ex tc IIIC T135°C Dc IP65 -40°C ≤ Ta ≤ +60°C (+50°C w/ I.C. Coil)   Ex nA nC IIC T4 Gc -50°C ≤ Ta ≤ +60°C Ex nA nC IIC T5 Gc -50°C ≤ Ta ≤ +50°C Ex tc IIIC T135°C Dc IP65 Ex tc IIIC T135°C Dc IP65	ABNT NBR: IEC 60079-0 IEC 60079-11 IEC 60079-31	 Ex ia IIC T5 Gb -50°C ≤ Ta ≤ +50°C Ex tc IIIC T135°C Dc IP65
KTL	Not Applicable	None	Announcement No. 2010-36 of Ministry of Employment and Labor 	Ex nA nC IIC T4 (-50°C ≤ Ta ≤ +60°C)	Announcement No. 2010-36 of Ministry of Employment and Labor 	Ex ia IIC T5 (-50°C ≤ Ta ≤ +50°C)

	General Purpose Valves 8111, 8121, 8011, 8021 Series		Non-Incendive/Non-Sparking Valves 8112, 8122, 8012, 8022 Series		Intrinsically Safe Valves 8113, 8123, 8013, 8023 Series	
	Standards	Markings	Standards	Markings	Standards	Markings
<b>AGA Certifications</b>	AS 4629	None	AS 4629	None	AS 4629	None
<b>EAC Certifications</b>	RUC-BE. AM30.B.00711		Not Applicable	None	TP TC 012/2011 ГОСТ 31610.0-2014 (IEC 60079-0) ГОСТ 31610.11-2014 (IEC 60079-11) ГОСТ Р МЭК (IEC 60079-31)	 RUC-US.AЖ58.B.01684/21
<b>Chinese Approvals</b>	None	None	GB 3836.1 GB 3836.8 GB 12476.1 GB 12476.5	 Ex nA nC IIC T4 Gc (T5 w/ IS coil) -50°C < Ta < +60°C (+50°C w/ IS coil) Ex tD A22 IP65 T135°C	GB 3836.1 GB 3836.4 GB 12476.1 GB 12476.5	 Ex ia IIC T5 Gb -50°C < Ta < +50°C Ex tD A22 IP65 T135°C

<sup>1</sup> Product complies with the essential requirements of the following: Gas Appliance Regulation (EU) 2016/426, Low Voltage Directive (2014/35/EU), and Pressure Equipment Directive (2014/68/EU) up to 4"

<sup>2</sup> Product certified to meet the following: ATEX Directive 2014/34/EU Class A, Group 2 per EN 161

## VALVE MODEL NUMBER DESCRIPTION

Every MAXON Series 8000 Valve can be accurately identified by the model number shown on the valve nameplate. The example below shows a typical Series 8000 Valve model number, along with the available choices for each item represented in the model number. The first five choices determine the valve's configured item number. Valve body and actuator options are identified by the next nine characters in the model number. Options and accessories are listed on the next page.

Configured Item Number					Valve Body					Actuator					
Valve Size	Flow Capacity	Pressure Rating	Normal Position	Area Classification	Body Connection	Body Seals	Body Material	Internal Trim Package	Primary Voltage	Switch Option	Enclosure Rating	Instruction Language	Visual Indication		
300	C	81	1	1	-	A	A	1	1	-	B	1	A	1	1

### Valve Size

075 – 3/4" (DN 20)  
 100 – 1" (DN 25)  
 125 – 1-1/4" (DN 32)  
 150 – 1-1/2" (DN 40)  
 200 – 2" (DN 50)  
 250 – 2-1/2" (DN 65)  
 300 – 3" (DN 80)  
 400 – 4" (DN 100)  
 600 – 6" (DN 150)  
 800 – 8" (DN 200)

### Flow Capacity

S – Standard  
 C – CP Body Construction

### Operating Pressure Rating

80 – Pneumatic Standard Pressure  
 81 – Pneumatic High Pressure

### Normal Position

1 – Normally-Closed Shut-Off Valve  
 2 – Normally-Open Vent Valve

### Area Classification

1 – General Purpose  
 2 – Non-incendive, Class I, II and III Division 2  
 3 – Intrinsically Safe, Class I, II and III Division 1 (and ATEX Zone 1/21 when ordered with the ATEX IS solenoid) <sup>1</sup>  
 4 – Valve Body Only

### Body Connection

A – NPT  
 B – ANSI Flanged (ISO 7005 PN 20)  
 C – ISO 7-1 Threaded  
 D – DIN PN 16 Flanged  
 E – Socket Welded Nipple  
 F – Socket Welded Nipple w/Class 150 Flange (ISO 7005 PN 20)  
 G – Socket Welded Nipple w/Class 300 Flange (ISO 7005 PN 50)  
 H – EN1092-1 PN16 (ISO 7005-1 PN16)  
 J – ANSI Class 300 Flange (ISO 7005 PN 50)  
 U – Actuator Only

### Body Seals

A – Buna-N  
 B – Viton  
 C – Ethylene Propylene <sup>2</sup>  
 F – Omniflex <sup>5</sup>  
 X – Special  
 U – Actuator Only

### Body Material

1 – Cast Iron  
 2 – Carbon Steel  
 5 – Stainless Steel  
 6 – Low Temp Carbon Steel  
 X – Special  
 U – Actuator Only

### Internal Trim Package

1 – Trim Package 1  
 2 – Trim Package 2  
 3 – Trim Package 3 (NACE)  
 4 – Trim Package 2 + oxy clean <sup>2</sup>  
 5 – Trim Package 3 + oxy clean <sup>2</sup>  
 6 – Trim Package 2 + fire safe  
 7 – Trim Package 3 + fire safe  
 X – Special <sup>2</sup>  
 U – Actuator Only

### Primary Voltage <sup>4</sup>

A – 120VAC 50Hz  
 B – 120VAC 60Hz  
 D – 240VAC 50Hz  
 E – 240VAC 60Hz  
 G – 24VDC  
 H – 24VDC IS <sup>1</sup>  
 J – 24VDC IS-ATEX <sup>1</sup>  
 X – Special  
 Z – None (customer-supplied, external mount) <sup>3</sup>

### Switch Option <sup>4</sup>

0 – None  
 1 – VOS1/VCS1 - V7  
 2 – VOS2/VCS2 - V7  
 3 – VOS1/VCS1 - IP67  
 4 – VOS2/VCS2 - IP67  
 X – Special

### Enclosure Rating <sup>4</sup>

A – NEMA 4, IP65  
 B – NEMA 4X, IP65  
 X – Special

### Instruction Language <sup>4</sup>

0 – English  
 1 – French  
 3 – German  
 4 – Portuguese  
 5 – Spanish

### Visual Indication <sup>4</sup>

1 – Red closed/green open  
 2 – Green closed/red open  
 3 – Black closed/yellow open

<sup>1</sup> 122°F maximum ambient temperature limit

<sup>2</sup> 0°F minimum ambient temperature limit

<sup>3</sup> FM Approvals not applicable

<sup>4</sup> Not a selection on Body Only

<sup>5</sup> Omniflex seals mandatory with -58°F fuel temperature option



## Options and accessories

Certifications <sup>1</sup>							Inspections			
Material Cert Required	Casting Inspection Specification	Casting Inspection (NDE) 1	Casting Inspection (NDE) 2	Weld Inspection Specification	Weld Inspection (NDE) 1	Weld Inspection (NDE) 2	Pre-build Material FAT	Final Verification FAT	Redundant Solenoid	Speed Control
N	1	1	1	1	1	0	N	N	1	2

**Material Cert Required**

N – No

Y – Yes

**Casting Inspection Specification**

0 – None

1 – Casting per ASME B31.1

2 – Casting per ASME B31.3

3 – Casting per ASME B16.34

4 – MSS-SP55

**Casting Inspection (NDE) 1<sup>1</sup>**

0 – None

1 – Liquid Penetrant Inspection (PT)

2 – Magnetic Particle Inspection (MT)

4 – Positive Material Identification (PMI)

**Casting Inspection (NDE) 2<sup>1</sup>**

0 – None

1 – Liquid Penetrant Inspection (PT)

2 – Magnetic Particle Inspection (MT)

4 – Positive Material Identification (PMI)

**Weld Inspection Specification**

0 – None

1 – Weld per ASME B31.1

2 – Weld per ASME B31.3

**Weld Inspection (NDE) 1<sup>1</sup>**

0 – None

1 – Liquid Penetrant Inspection (PT)

2 – Magnetic Particle Inspection (MT)

**Weld Inspection (NDE) 2<sup>1</sup>**

0 – None

1 – Liquid Penetrant Inspection (PT)

2 – Magnetic Particle Inspection (MT)

**Pre-build Material FAT**

N – No

X – Special

**Final Verification FAT**

N – No

X – Special

**Redundant Solenoid<sup>3</sup>**

0 – None

1 – External Redundant Solenoid

2 – External Redundant Manual Reset Solenoid

**Speed Control<sup>3</sup>**

0 – None

1 – Speed Control Valve, Steel

2 – Speed Control Valve, Stainless Steel

<sup>1</sup> Material certifications provided for valve body, bonnet, pipe nipples (when applicable) and flanges (when applicable). Material certifications for other components may be available by special request.

<sup>2</sup> Agency approvals and certifications apply to valve only and do not apply to optional external accessories, such as redundant solenoids.

<sup>3</sup> Not a selection on Body Only

## VALVE BODY ASSEMBLY OPTIONS & SPECIFICATIONS

Series 8000 Normally-Closed Shut-Off Valves								
Nominal Pipe Size	Flow Capacity	Actuator Pressure Class	Body Connections Available	Body Material	Trim Package Options	Cv Rating	Flow @ MOPD (in SCFM)	MOPD Rating (psig)
.75"	Std.	High Press.	A, C	1, Cast Iron	1, 2, 3, 4, 5	19	3500	200
			A, C, E, F, G	2, 6 Carbon Steel 5, Stainless Steel	2, 3, 4, 5, 6, 7		4400	255
1"	Std.	High Press.	A, C	1, Cast Iron	1, 2, 3, 4, 5	20	3700	200
			A, C, E, F, G	2, 6 Carbon Steel 5, Stainless Steel	2, 3, 4, 5, 6, 7		4650	255
1.25"	Std.	High Press.	A, C	1, Cast Iron	1, 2, 3, 4, 5	45	8300	200
1.5"	Std.	High Press.	A, C	1, Cast Iron	1, 2, 3, 4, 5	53	9800	200
			A, C, E, F, G	2, 6 Carbon Steel 5, Stainless Steel	2, 3, 4, 5, 6, 7		12300	255
2"	Std.	High Press.	A, B, C, D, H	1, Cast Iron	1, 2, 3, 4, 5	86	15900	200
			A, C, E, F, G	2, 6 Carbon Steel 5, Stainless Steel	2, 3, 4, 5, 6, 7		20000	255
2.5"	Std.	High Press.	A, B, C, D	1, Cast Iron	1	127	18000	150
			A, B, C, D	1, Cast Iron	1, 2, 3, 4, 5		304	16600
	CP	Std.	B, D, H, G	2, 6 Carbon Steel 5, Stainless Steel	2, 3, 4, 5	49700		175
			High Press.	A, B, C, D, H	1, Cast Iron		1, 2, 3, 4, 5	5, Stainless Steel
3"	Std.	High Press.		A, C	1, Cast Iron	1	173	
			CP	Std.	A, B, C, D, H	1, Cast Iron		1, 2, 3, 4, 5
	High Press.	B, D, H, G			2, 6 Carbon Steel 5, Stainless Steel	2, 3, 4, 5	54500	135
		A, B, C, D, H	1, Cast Iron	1, 2, 3, 4, 5	2, 3, 4, 5, 6, 7			
4"	CP	Std.	B, D, H, G	1, Cast Iron		1, 2, 3, 4, 5	490	22300
				2, 6 Carbon Steel 5, Stainless Steel	2, 3, 4, 5	63100		135
	High Press.	1, Cast Iron	1, 2, 3, 4, 5	2, 3, 4, 5, 6, 7				
		2, 6 Carbon Steel 5, Stainless Steel	2, 3, 4, 5, 6, 7					
6"	Std.	Std.	B, D, H	1, Cast Iron	1, 2, 3, 4, 5	1172	74200	60
				2, 6 Carbon Steel 5, Stainless Steel	2, 3, 4, 5, 6, 7		115000	100
	High Press.			1, Cast Iron	1, 2, 3, 4, 5			2, 3, 4, 5, 6, 7
				2, 6 Carbon Steel 5, Stainless Steel	2, 3, 4, 5, 6, 7			
8"	Std.	Std.	B, D, H, J	2, 6 Carbon Steel	2, 3, 4, 5, 6, 7	1320	83600	60
				5, Stainless Steel	2, 3, 4, 5, 6, 7		130000	100
	High Press.			2, 6 Carbon Steel				2, 3, 4, 5, 6, 7
				5, Stainless Steel				

### Body Connections:

**A** - NPT  
**B** - ANSI Flanged (ISO 7005 PN20)  
**C** - ISO 7-1 Threaded  
**D** - DIN PN16 Flanged  
**E** - Socket Welded Nipple  
**F** - Socket Welded Nipple w/Class 150 Flange (ISO 7005 PN20)  
**G** - Socket Welded Nipple w/Class 300 Flange (ISO 7005 PN50)  
**H** - EN1092-1 PN16 (ISO 7005-1 PN16)  
**J** - ANSI Class 300 Flange (ISO 7005 PN50)

### Body Material:

**1** - Cast Iron  
**2** - Carbon Steel  
**5** - Stainless Steel  
**6** - Low Temp Carbon Steel

### Trim Package Options and Typical Material:

**1** - 400 Series Stainless Steel Seat, Hardened Ductile Iron Disc, PEEK Follower Ring, 17-4 Stainless Steel Stem  
**2** - 300 Series Stainless Steel Seat, 300 Series Stainless Steel Disc, PEEK Follower Ring, 17-4 Stainless Steel Stem  
**3** - 300 Series Stainless Steel Seat, 300 Series Stainless Steel Disc, 300 Series Stainless Steel Stem, PEEK Follower Ring (NACE compliant), 300 Series Stainless Steel Stem  
**4** - Oxy Clean, Trim 2  
**5** - Oxy Clean, Trim 3  
**6** - Trim 2 fire safe + Stainless Steel Follower Ring, and compressed graphite backup Seals  
**7** - Trim 3 fire safe + Stainless Steel Follower Ring, and compressed graphite backup Seals

### Body Seals:

All configurations allow for Buna-N and Viton elastomers as standard. Omniflex and Ethylene Propylene are available for special services. Consult MAXON for proper application.

Series 8000 Normally-Open Vent Valves								
Nominal Pipe Size	Flow Capacity	Actuator Pressure Class	Body Connections Available	Body Material	Trim Package Options	Cv Rating	Flow @ MOPD (in SCFM)	MOPD Rating (psig)
.75"	Std.	High Press.	A, C	1, Cast Iron	1, 2, 3, 4, 5	19	3500	200
			A, C, E, F, G	2, 6 Carbon Steel	2, 3, 4, 5, 6, 7		4400	255
				5, Stainless Steel				
1"	Std.	High Press.	A, C	1, Cast Iron	1, 2, 3, 4, 5	20	3700	200
			A, C, E, F, G	2, 6 Carbon Steel	2, 3, 4, 5, 6, 7		4650	255
				5, Stainless Steel				
1.5"	Std.	High Press.	A, C	1, Cast Iron	1, 2, 3, 4, 5	53	9800	200
			A, C, E, F, G	2, 6 Carbon Steel	2, 3, 4, 5, 6, 7		12300	255
				5, Stainless Steel				
2"	Std.	High Press.	A, B, C, D, H	1, Cast Iron	1, 2, 3, 4, 5	86	15900	200
			A, C, E, F, G	2, 6 Carbon Steel	2, 3, 4, 5, 6, 7		20000	255
				5, Stainless Steel				
2.5"	CP	Std.	A, B, C, D	1, Cast Iron	1, 2, 3, 4, 5	304	16600	50
			B, D, H	2, 6 Carbon Steel	2, 3, 4, 5			
				5, Stainless Steel				
		High Press.	A, B, C, D, H	1, Cast Iron	1, 2, 3, 4, 5		49700	175
			B, D, H	2, 6 Carbon Steel	2, 3, 4, 5, 6, 7			
				5, Stainless Steel				
3"	CP	Std.	A, B, C, D, H	1, Cast Iron	1, 2, 3, 4, 5	423	19300	40
			B, D, H	2, 6 Carbon Steel	2, 3, 4, 5			
				5, Stainless Steel				
		High Press.	A, B, C, D, H	1, Cast Iron	1, 2, 3, 4, 5		54500	135
			B, D, H	2, 6 Carbon Steel	2, 3, 4, 5, 6, 7			
				5, Stainless Steel				
4"	CP	Std	B, D, H	1, Cast Iron	1, 2, 3, 4, 5	490	22300	40
				2, 6 Carbon Steel	2, 3, 4, 5			
		High Press.		1, Cast Iron	1, 2, 3, 4, 5		63100	135
				2, 6 Carbon Steel	2, 3, 4, 5, 6, 7			
				5, Stainless Steel				

**Body Connections:**

- A - NPT
- B - ANSI Flanged (ISO 7005 PN20)
- C - ISO 7-1 Threaded
- D - DIN PN16 Flanged
- E - Socket Welded Nipple
- F - Socket Welded Nipple w/Class 150 Flange (ISO 7005 PN20)
- G - Socket Welded Nipple w/Class 300 Flange (ISO 7005 PN50)
- H - EN1092-1 PN16 (ISO 7005-1 PN16)

**Body Material:**

- 1 - Cast Iron
- 2 - Carbon Steel
- 5 - Stainless Steel
- 6 - Low Temp Carbon Steel

**Trim Package Options and Typical Material:**

- 1 - 400 Series Stainless Steel Seat, Hardened Ductile Iron Disc, PEEK Follower Ring, 17-4 Stainless Steel Stem
- 2 - 300 Series Stainless Steel Seat, 300 Series Stainless Steel Disc, PEEK Follower Ring, 17-4 Stainless Steel Stem
- 3 - 300 Series Stainless Steel Seat, 300 Series Stainless Steel Disc, 300 Series Stainless Steel Stem, PEEK Follower Ring (NACE compliant), 300 Series Stainless Steel Stem
- 4 - Oxy Clean, Trim 2
- 5 - Oxy Clean, Trim 3
- 6 - Trim 2 fire safe + Stainless Steel Follower Ring, and compressed graphite backup Seals
- 7 - Trim 3 fire safe + Stainless Steel Follower Ring, and compressed graphite backup Seals

**Body Seals:**

All configurations allow for Buna-N and Viton elastomers as standard. Omniflex and Ethylene Propylene are available for special services. Consult MAXON for proper application.

# VALVE BODY ASSEMBLY SPECIFICATIONS

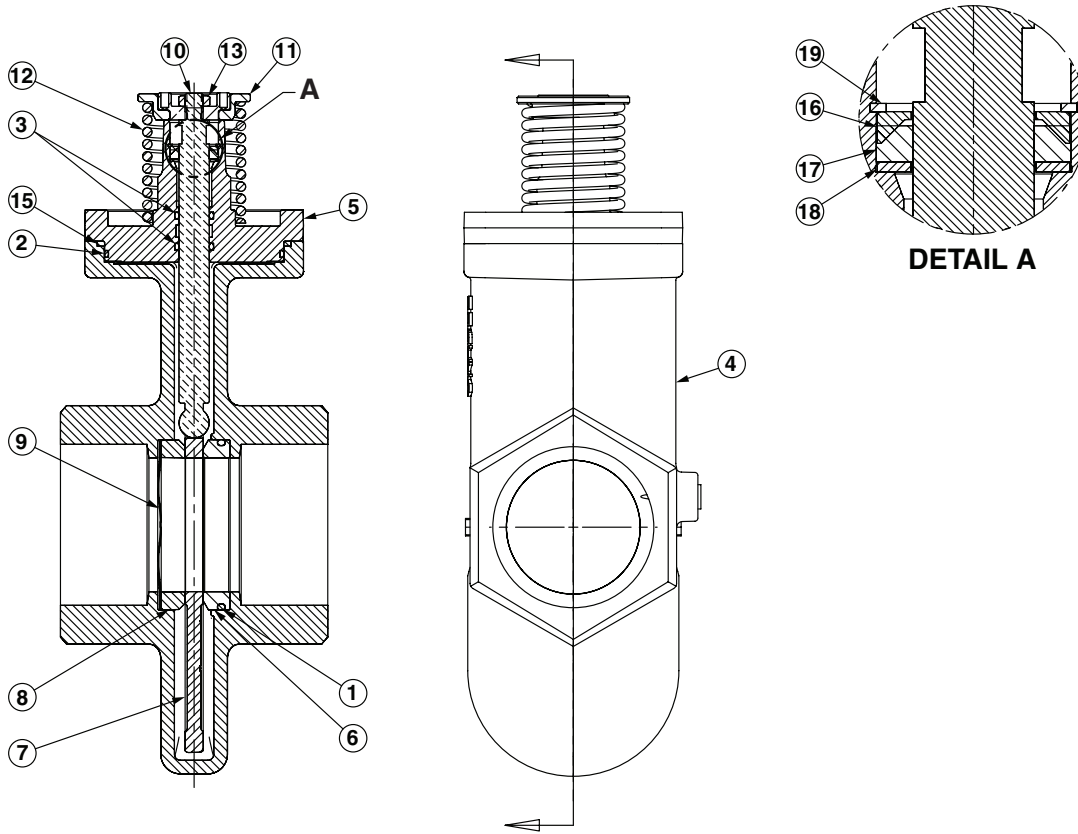

Body Seal Material		
Item No.	Description	Material
1	Seat O-Ring	Standard material options are Buna-N and Viton. Omniflex and Ethylene Propylene are available for special service. Consult MAXON for proper material selection.
2	Body O-Ring	
3	Stem O-Ring	

Body and Bonnet Materials					
Item No.	Description	Material Code			
		1	2	5	6
4	Body	Cast Iron ASTM A126, Class B	Cast Steel ASTM A216 Gr. WCB	Stainless Steel ASTM A351 Gr. CF8M	Low Temp Carbon Steel ASTM A352 Gr. LCB
5	Bonnet				

Trim Package Materials						
Item No.	Description	Internal Trim Package				
		1	2 & 4	3 & 5	6	7
6	Seat	Hardened 440C Stainless Steel	316 Stainless Steel (ASTM A276-67)			
7	Disc	ASTM A536 Ductile Iron (80-55-06)	316 Stainless Steel (ASTM A240/A240M-97a)			
8	Follower Ring	PEEK 30% reinforced with carbon fiber/graphite/PTFE			316 Stainless Steel (ASTM A276-67)	
9	Wavy Spring	302 Stainless Steel				
10	Stem	17-4 PH Stainless Steel		316 Stainless Stl (ASTM A276-67)	17-4 PH Stainless Steel	316 Stainless Stl (ASTM A276-67)
11	Spring Retainer	ASTM A108-72 GRADE 1020 Carbon Steel (Blackened)				
12	Compression Spring	17-7 PH Stainless Steel ASTM A313 TYPE 631				
13	Jam Nut	Zinc Plated Carbon Steel				
14	Spring Pin (when req'd.)	Carbon Steel				
15	Body Graphite Ring	---	---	---	Flexible Graphite	
16	Packing Washer	---	---	---	316 Stainless Steel (ASTM A276-67)	
17	Stem Graphite Ring	---	---	---	Flexible Graphite	
18	Flat Washer	---	---	---	316 Stainless Steel (ASTM A276-67)	
19	Retaining Ring	---	---	---	Zinc Plated Carbon Steel	

## VALVE BODY ASSEMBLY – COMMON GAS COMPATIBILITY

Gas	Gas Code	Suggested Material Options			MOPD Rating	Agency Approvals and Certifications			
		Seals & Bumper	Body & Bonnet <sup>7</sup>	Trim Option <sup>5</sup>		FM	CSA <sup>3</sup>	CE <sup>4</sup>	
								GAR <sup>6</sup>	PED <sup>7</sup>
Air (dry)	AIR	A, B, F	1, 2, 5, 6	1, 2, 3, 6, 7	Std.	X	X		X
Ammonia	AMM	A <sup>8</sup> , C, F	1, 2, 5, 6	1, 2, 3, 6, 7	Std.	X			X
Butane Gas	BUT	A, B, F	1, 2, 5, 6	1, 2, 3, 6, 7	Std.	X	X	X	X
Coke Oven Gas	COKE	B, F	5	Analysis Required	Std.	X			X
Digester <sup>1</sup>	DIG	Analysis Required	5	Analysis Required	Std.	X			X
Endothermic AGA	ENDO	A, B, F	1, 2, 5, 6	1, 2, 3, 6, 7	Std.	X	X		X
Exothermic Gas	EXO	A, B, F	1, 2, 5, 6	1, 2, 3, 6, 7	Std.	X	X		X
Hydrogen Gas	HYD	A, B, C, F	1, 2, 5, 6	1, 2, 3, 6, 7	Reduced <sup>2</sup>	X			X
Manufactured <sup>1</sup>	MFGD	Analysis Required	5	Analysis Required	Std.	X	X		X
Natural Gas	NAT	A, B, F	1, 2, 5, 6	1, 2, 3, 6, 7	Std.	X	X	X	X
Nitrogen	NIT	A, B, C, F	1, 2, 5, 6	1, 2, 3, 6, 7	Std.	X	X		X
Oxygen (High P)	OXYH	B, C, F	2, 5, 6	4, 5	200 psig	X			X
Oxygen (Low P)	OXYL	B, C, F	1, 2, 5, 6	4, 5	30 psig	X			X
Oxygen X	OXYX	B, C, F	2, 5, 6	4, 5	Std.	X			X
Propane	PROP	A, B, F	1, 2, 5, 6	1, 2, 3, 6, 7	Std.	X	X	X	X
Refinery <sup>1</sup>	REF	Analysis Required	5	Analysis Required	Std.	X			X
Sour Natural Gas <sup>1</sup>	SOUR	Analysis Required	5	Analysis Required	Std.	X			X
Town Gas <sup>1</sup>	TOWN	Analysis Required	5	Analysis Required	Std.	X	X	X	X
Land Fill Gas <sup>1</sup>	LAND	Analysis Required	5	Analysis Required	Std.	X			X

### Notes:

<sup>1</sup> Other body and trim packages may be acceptable pending fuel analysis. For pricing inquiries, Viton or Omniflex o-rings should be used. Contact MAXON for details.

<sup>2</sup> Valve maximum operating pressure differential (MOPD) to be reduced by 25% from standard ratings.

<sup>3</sup> ISO connections are not recognized by CSA or UL standards.

<sup>4</sup> 8000 Series electro-pneumatic valves meet the essential requirements of the Low Voltage - LVD (2014/35/EU), Gas Appliances - GAR (EU) 2016/426, and Pressure Equipment - PED (2014/68/EU) Directives.

<sup>5</sup> Trim Option 1 is only allowed with Body and Bonnet Option 1.

<sup>6</sup> The Gas Appliance Regulation only covers the use of commercially available fuels (natural gas, butane, town gas and propane).

<sup>7</sup> PED certification limited to 1-1/2" through 4" valves with steel or stainless steel body options (2, 5, 6). Body option 2 has a min ambient temp of -20°F.

<sup>8</sup> Buna components in Ammonia service are limited to a maximum fluid temp of 70°F

### Body Seals:

**A** - Buna-N B - Viton  
**C** - Ethylene Propylene  
**F** - Omniflex

### Body & Bonnet:

**1** - Cast Iron  
**2** - Carbon Steel  
**5** - Stainless Steel  
**6** - Low Temp Carbon Steel

### Trim Package:

**1** - Trim Package 1  
**2** - Trim Package 2  
**3** - Trim Package 3 (NACE)  
**4** - Trim Package 2, Oxy Clean  
**5** - Trim Package 3, Oxy Clean  
**6** - Trim 2 fire safe  
**7** - Trim 3 fire safe

# VALVE ACTUATOR ASSEMBLY SPECIFICATIONS

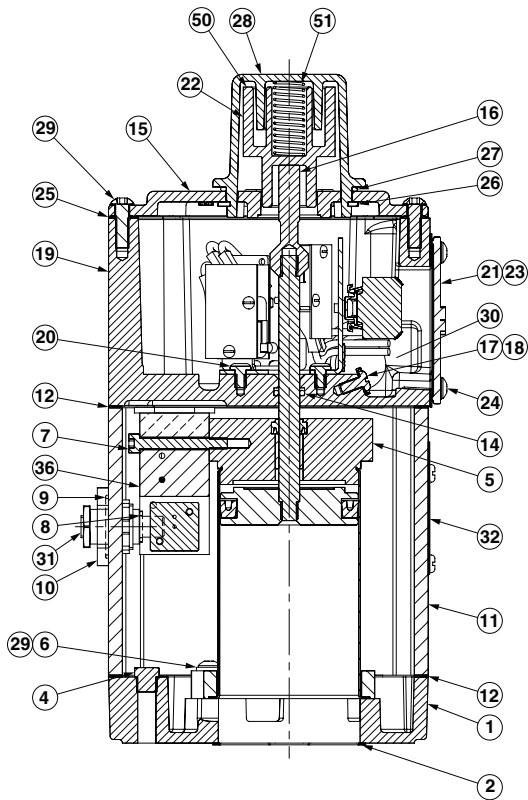

Typical Actuator Assembly

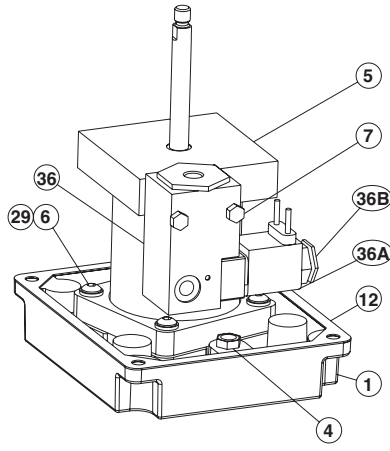

Typical Cylinder Assembly Mounting

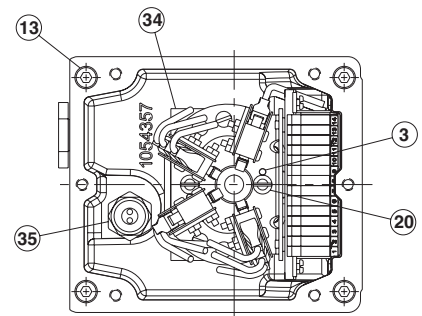

View Without Top Plate

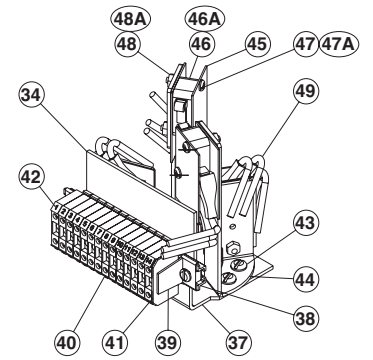

General Purpose Switch Assembly

Item Number	Description	Item No.	Description
1	Base Plate	29	M6-1.0 x 20 Cap Screw
2	Bonnet Gasket	30	3/4" Pipe Plug
3	Drive Pin	31	.125 Inlet Pipe Plug
4	Filter Vent	32	Info Plate
5	Cylinder Assembly	33	Actuator Bolts (not shown)
6	M6 Lock Washer	34	Switch Assembly
7	M5-0.8 x 40 Hex Screw	35	Liquid Tight Connector
8	O-Ring	36	Solenoid w/Quick Exhaust Assembly
9	O-Ring	36A	Solenoid Coil
10	Solenoid Adapter Inlet	36B	Solenoid Cap
11	Housing	37	Switch & Terminal Bracket
12	Housing Gasket	38	DIN Rail
13	M6-1.0 x 60 Soc HD Cap Screw	39	End Stop
14	O-Ring	40	Terminal Block
15	Top Plate	41	End Cover
16	Switch Indicator	42	Marker Strips
17	Washer	43	M4-0.7 x 6 Slotted Screw
18	M5-0.8 x 10 Ground Screw	44	Switch Bracket
19	Top Housing	45	Switch Insulator
20	M4-0.7 x 6 Slotted Screw	46	V7 Switch
21	Terminal Block Cover Gasket	46A	IP67 Switch
22	Info Label	47	#4-40 x .75 Slotted Screw
23	Terminal Block Cover	47A	#2-56 x .437 Slotted Screw
24	M5-0.8 x 12 Cap Screw	48	#4-40 Hex Nut
25	Top Housing Gasket	48A	#2-56 Hex Nut
26	External Retaining Ring	49	Wire
27	O-Ring	50	Visual Indicator
28	Indicator Cover	51	Spring

# ELECTRICAL DATA

## GENERAL

Series 8000 Valves are pneumatically operated and a solenoid valve controls the air supply. The solenoid valve is directly wired into the control system.

**Position switch wiring diagrams** (reproduced below) are part of each valve assembly, summarizing electrical data and wiring for a valve equipped with terminal block and a full complement of optional switches.

Good practice normally dictates that auxiliary switches in valves should be used for signal duty only, not to operate additional safety devices.

**Valve position switches** are offered in SPDT (Single Pole/Double Throw). Recommended packages include one open switch and one closed switch (VOS1/VCS1) and additional auxiliary switches designated by VOS2/VCS2.

**VCS** (Valve Closed Switch) is actuated at the end of the closing stroke.

**VOS** (Valve Open Switch) is actuated at the end of the opening stroke.

Switch current ratings are shown on the schematic wiring diagrams below. **DO NOT EXCEED** rated current or total load shown. Diagrams show valve with a full complement of switches. The indicated internal wiring is present only when the appropriate auxiliary switches are specified.

Figure 1: Normally-Closed Shut-Off Valve

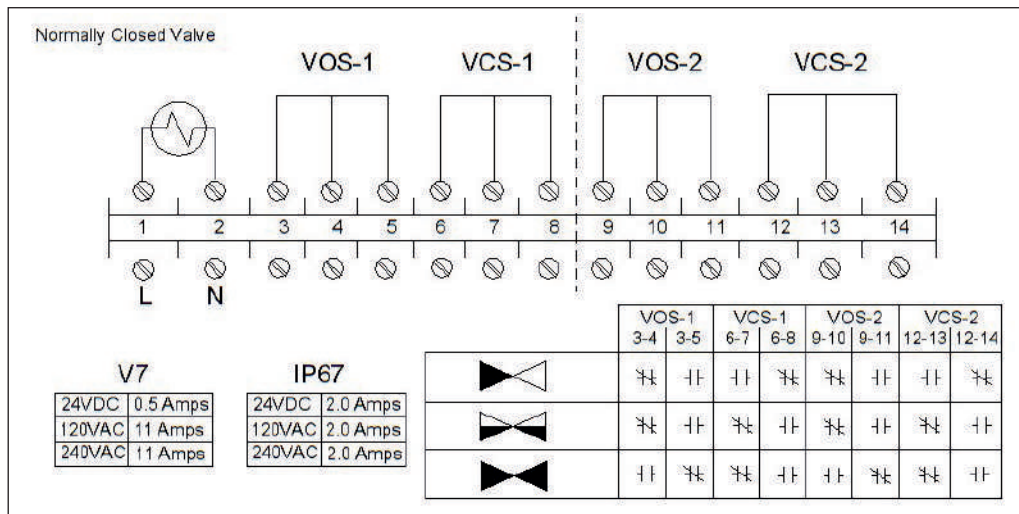
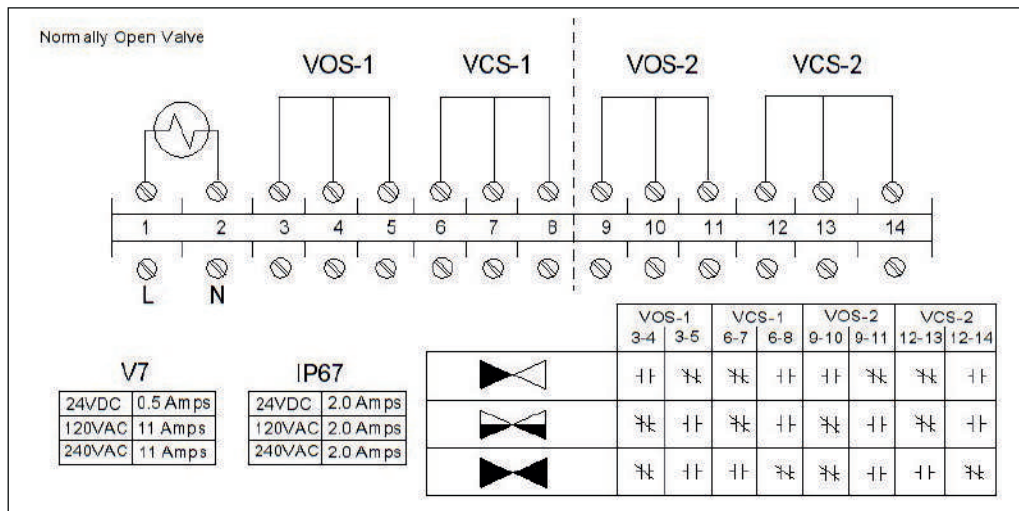

Figure 2: Normally-Open Vent Valve



**General Purpose - Series 8011, 8111, 8021 & 8121**

Solenoid valve power ratings <sup>1</sup>				
Voltage	Current (A)		Power	
	In-Rush	Holding	In-Rush	Holding
24VDC	0.20	0.20	4.8 W	4.8 W
120VAC 50 Hz	0.09	0.07	11 VA	8.5 VA
120VAC 60 Hz	0.08	0.05	9.4 VA	6.9 VA
240VAC 50 Hz	0.05	0.04	11 VA	8.5 VA
240VAC 60 Hz	0.04	0.03	9.4 VA	6.9 VA

Standard switch current ratings as shown on the valve switch wiring diagram	
Voltage	Maximum Current (A)
24VDC	0.5
120VAC 50/60 Hz	11
240VAC 50/60 Hz	11

**Non-incendive Valves - Series 8012, 8112, 8022 & 8122**

Solenoid valve power ratings <sup>1</sup>				
Voltage	Current (A)		Power	
	In-Rush	Holding	In-Rush	Holding
24VDC	0.20	0.20	4.8 W	4.8 W
120VAC 50 Hz	0.09	0.07	11 VA	8.5 VA
120VAC 60 Hz	0.08	0.05	9.4 VA	6.9 VA
240VAC 50 Hz	0.05	0.04	11 VA	8.5 VA
240VAC 60 Hz	0.04	0.03	9.4 VA	6.9 VA
24VDC IS	0.09	0.09	2.1 W	2.1 W

IP67 switch current ratings as shown on the valve switch wiring diagram	
Voltage	Maximum Current (A)
24VDC	2.0
120VAC 50/60 Hz	2.0
240VAC 50/60 Hz	2.0

<sup>1</sup> Does not apply to Voltage Option Z



## INTRINSICALLY SAFE VALVES - SERIES 8013, 8023, 8113 & 8123

The Series 8000 Valve achieves Class I Div.1 hazardous location certification through the Intrinsically Safe (IS) protection method. Below is a representation of the Control Drawing. The MAXON standard offering does not include the barriers/isolators that are depicted below in the non-hazardous location; however, they can be provided as an additional accessory. Consult MAXON for details.

The intrinsic safety and operational criteria for most applications can be met with a 24 VDC supply and the barriers described in the Control Drawing. Specific installations with long cable runs, low power requirements, or other complications may require a barrier with different parameters.

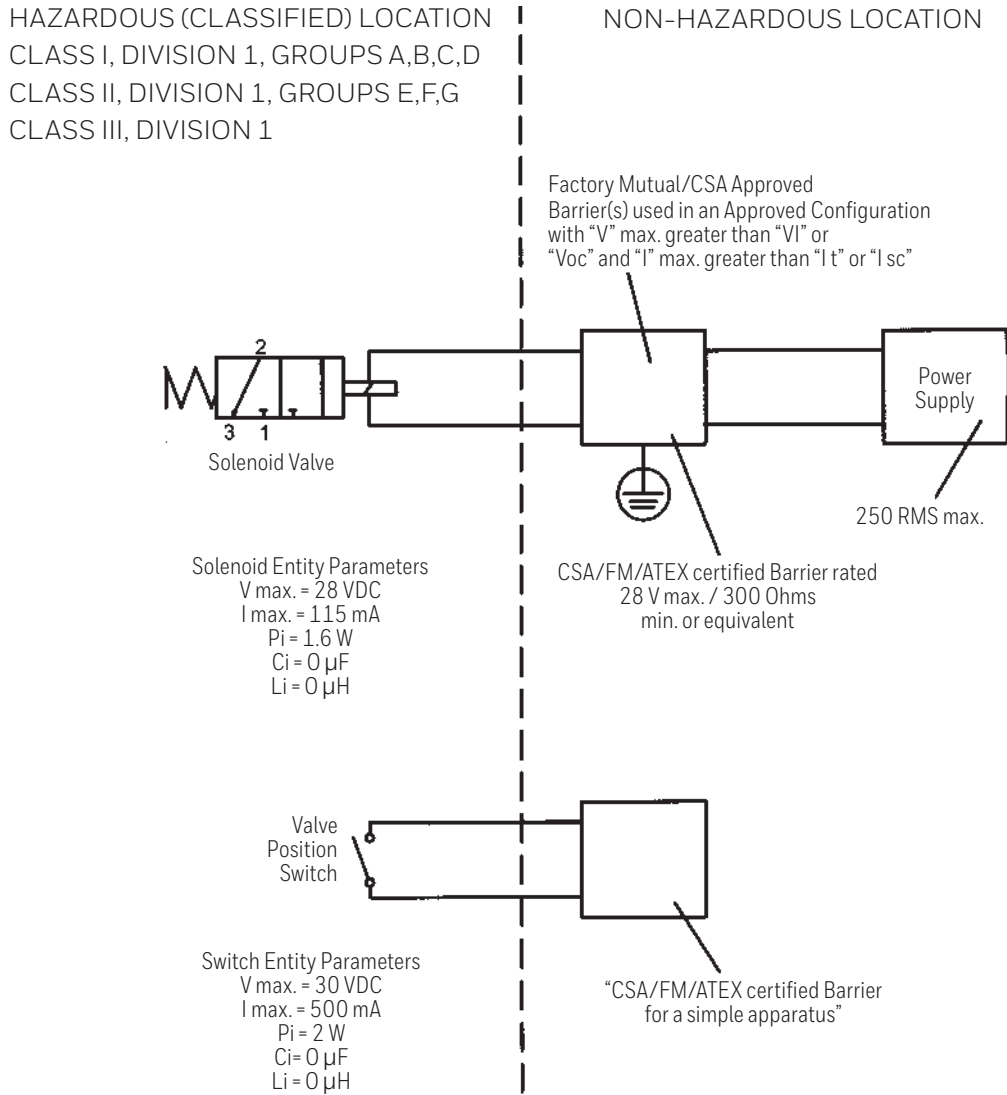

### NOTES:

- 1) The Intrinsic Safety Entity concept allows the interconnection of two FM approved (CSA Certified when installed in Canada) Intrinsically Safe devices with entity parameters not specifically examined in combination as a system when:  
 $V_{oc} \text{ or } U_o \text{ or } V_i \leq V_{max}$ ,  $I_{sc} \text{ or } I_o \text{ or } I_t \leq I_{max}$ ,  $C_a \text{ or } C_o \geq C_i + C_{cable}$ ,  $L_a \text{ or } L_o \geq L_i + L_{cable}$ , and for FM only:  $P_o \leq P_i$ .
- 2) Dust-tight conduit seal must be used when installed in Class II and Class III environments.
- 3) Control equipment connected to the Associated Apparatus must not use or generate more than 250 Vrms or Vdc.
- 4) Installation in the U.S. should be in accordance with ANSI/ISA RP12.06.01 "Installation of Intrinsically Safe Systems for Hazardous (Classified) Locations" and the National Electric Code® (ANSI/NFPA 70) Sections 504 and 505.
- 5) Installation in Canada should be in accordance with the Canadian Electrical Code, CSA C22.1, Part 1, Appendix F.
- 6) Installation in the European Union should be in accordance to Directive 2014/34/EU (ATEX).
- 7) The configuration of associated Apparatus must be FM Approved (CSA Certified when in Canada) under Entity Concept.
- 8) Associated Apparatus manufacturer's installation drawing must be followed when installing this equipment.
- 9) No revision to drawing without prior authorization from FM Approval and CSA International.

## CONTROL DRAWING FOR CUSTOMER-SUPPLIED, EXTERNALLY MOUNTED SOLENOIDS

HAZARDOUS (CLASSIFIED) LOCATION  
 CLASS I, DIVISION 1, GROUPS A,B,C,D  
 CLASS II, DIVISION 1, GROUPS E,F,G  
 CLASS III, DIVISION 1

NON-HAZARDOUS LOCATION

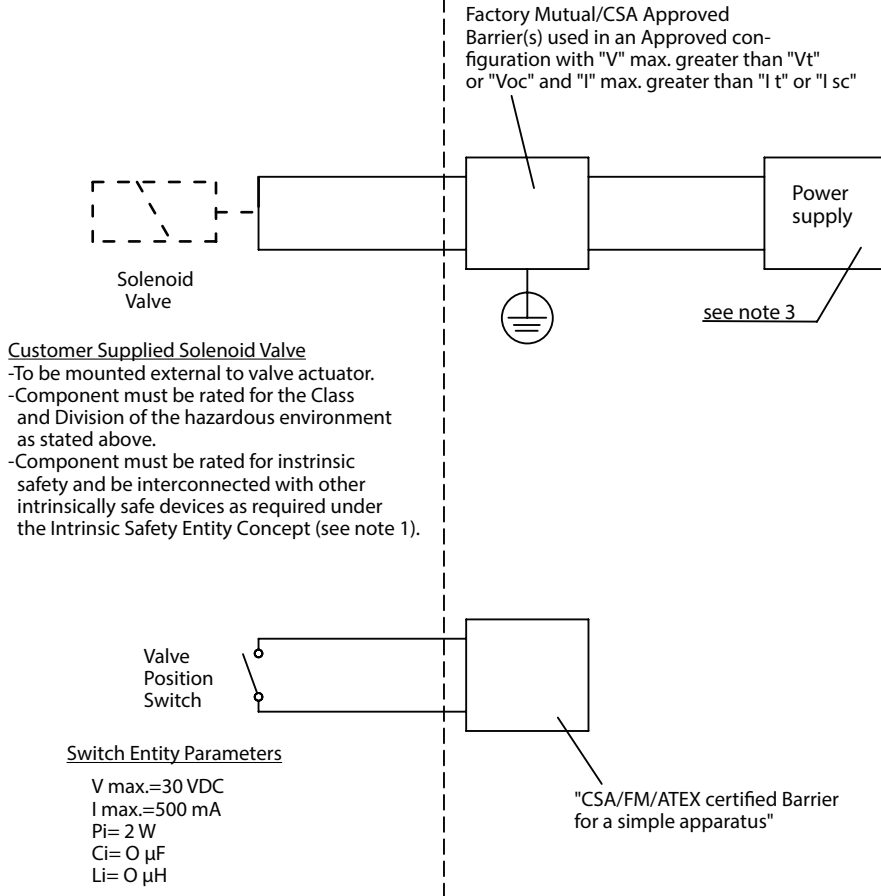

### NOTES:

- 1) The Intrinsic Safety Entity concept allows the interconnection of two FM approved (CSA Certified when installed in Canada) Intrinsically Safe devices with entity parameters not specifically examined in combination as a system when:  
 $V_{oc} \text{ or } U_o \text{ or } V_t \leq V_{max}, I_{sc} \text{ or } I_o \text{ or } I_t \leq I_{max}, C_a \text{ or } C_o \geq C_i + C_{cable}, L_a \text{ or } L_o \geq L_i + L_{cable}$ , and for FM only:  $P_o \leq P_i$ .
- 2) Dust-tight conduit seal must be used when installed in Class II and Class III environments.
- 3) Control equipment connected to the Associated Apparatus must not use or generate more than the maximum permissible safe area voltage ( $U_m$ ) for the barrier.
- 4) Installation in the U.S. should be in accordance with ANSI/ISA RP12.06.01 "Installation of Intrinsically Safe Systems for Hazardous (Classified) Locations" and the National Electric Code® (ANSI/NFPA 70) Sections 504 and 505.
- 5) Installation in Canada should be in accordance with the Canadian Electrical Code, CSA C22.1, Part 1, Appendix F.
- 6) Installation in the European Union should be in accordance to Directive 2014/34/EU (ATEX).
- 7) The configuration of associated Apparatus must be FM Approved (CSA Certified when in Canada) under Entity Concept.
- 8) Associated Apparatus manufacturer's installation drawing must be followed when installing this equipment.
- 9) No revision to drawing without prior authorization from FM Approval and CSA International.

To select a different safety barrier, choose a design that limits voltage, current, and power under worst-case fault conditions to values less than the IS entity parameters, while still meeting the minimum operational requirements under worst-case non-fault conditions. The IS entity parameters and operational requirements are listed in the following tables.

The barrier will specify a maximum voltage peak  $V_{oc}^1$ , a maximum short-circuit current,  $I_{sc}^2$  and maximum power output  $P_o^3$ . These barrier ratings must be less than or equal to the IS entity parameters of the field device, i.e.,  $V_{oc} \leq V_{max}$ ,  $I_{sc} \leq I_{max}$ , and  $P_o \leq P_i$ . The barrier will also specify a maximum allowed capacitance  $C_a$  and inductance  $L_a$ , which must be greater than or equal to the sum of those of the load device and field wiring, i.e.,  $C_a \geq C_i + C_{cable}$  and  $L_a \geq L_i + L_{cable}$ .

The solenoid requires a minimum current ( $I_{min}$ ) to operate properly. The nominal barrier input voltage ( $V_{working}$ , as specified by the barrier) must be adequate to provide  $I_{min}$  through the maximum barrier resistance, the maximum wiring resistance, the resistance of any fuses, and the maximum solenoid resistance ( $R_i$ ).



**NOTE:  $V_{working}$  will always be less than  $V_{max}$  or  $V_{oc}$ . Never intentionally supply  $V_{oc}$  to the barrier, as this could blow an internal fuse and ruin the barrier.**

- <sup>1</sup> The maximum voltage possible at the barrier input or output under a no-load condition.
- <sup>2</sup> Found when the barrier input is at  $V_{oc}$  and a short-circuit appears on the barrier output.
- <sup>3</sup> Found when the barrier input is at  $V_{oc}$  and a matched load appears on the barrier output. Note that this value is the transmitted power, and does not include the power dissipated by the barrier itself.

## BARRIER SELECTION CRITERIA FOR SOLENOID

IS entity parameters <sup>4</sup>	
Maximum voltage input ( $V_{max}$ )	28 V <sup>5</sup>
Maximum current input ( $I_{max}$ )	1.15 mA
Maximum power input ( $P_i$ )	1.6 W
Internal capacitance ( $C_i$ )	0 $\mu$ F
Internal inductance ( $L_i$ )	0 $\mu$ H
Operational Parameters	
Minimum operational current ( $I_{min}$ )	37 mA
Solenoid internal resistance ( $R_i$ )	275 ohms $\pm$ 8%

## BARRIER SELECTION CRITERIA FOR SWITCH

IS entity parameters (simple apparatus)	
Maximum voltage input ( $V_{max}$ )	30 V <sup>6</sup>
Maximum current input ( $I_{max}$ )	500 mA <sup>6</sup>
Maximum power input ( $P_i$ )	1.3 W <sup>7</sup>
Internal capacitance ( $C_i$ )	0 $\mu$ F
Internal inductance ( $L_i$ )	0 $\mu$ H
Operational Parameters	
Minimum operational current ( $I_{min}$ )	Application specific
Switch internal on-resistance ( $R_i$ )	< 1 ohm

- <sup>4</sup> Obtained from the manufacturer's published entity parameters.
- <sup>5</sup> Never intentionally supply  $V_{max}$  to the barrier, as this could blow an internal fuse and ruin the barrier.
- <sup>6</sup> Obtained from the switch's safety ratings.
- <sup>7</sup> Standard  $P_i$  for a simple apparatus.

## DIMENSIONS & WEIGHTS

### Series 8100 valve bodies: .75" (DN20) to 3" (DN80)

1) 2x 1/4" NPT test connection

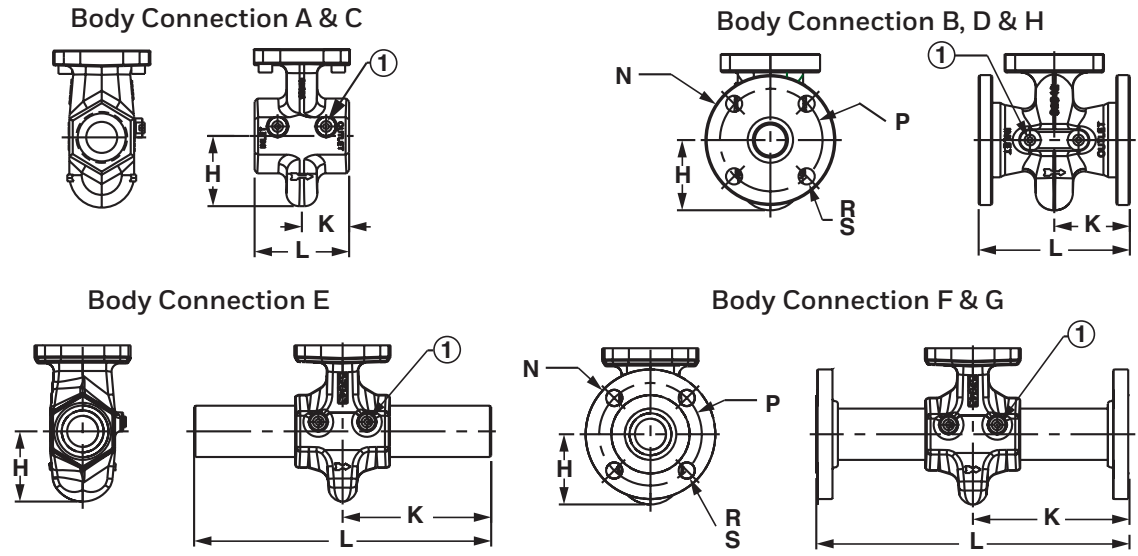

Valve Size	Flow Capacity	Body Connection	Body/ Bonnet Material	Approximate Dimensions (inches)							Approximate Weight (lbs)		
				H	K	L	N Ø	P Ø	R Ø	S # of holes	Body Assembly	Actuator Assembly	Total Weight
.75"	S	A, C	Cast Iron	2.0	1.9	3.8	N/A			4	8	12	20
		A, C	Carbon Steel & Stainless Steel		1.9	3.8	N/A				9		21
		E			6.9	13.8	N/A				11		23
		F			7.3	14.5	3.88	2.75	0.62	15	27		
		G					4.62	3.25	0.75	17	29		
1"	S	A, C	Cast Iron		1.9	3.8	N/A			8	20		
		A, C	Carbon Steel & Stainless Steel		1.9	3.8	N/A			9	21		
		E			6.9	13.8	N/A			11	23		
		F			7.3	14.5	4.3	3.1	0.62	15	27		
		G					4.9	3.5	0.75	17	29		
1.25"	S	A, C	Cast Iron	2.4			N/A			9	21		
1.5"	S	A, C	Cast Iron	2.7	2.0		4.0			11	23		
		A, C	Carbon Steel & Stainless Steel				N/A			11	23		
		E			6.8	13.6	N/A			14	26		
		F			7.2	14.4	5.0	3.9	0.62	21	33		
		G					6.1	4.5	0.88	26	38		
2"	S	A, C	Cast Iron		2.2	4.4	N/A			16	28		
		B			7.0	6.0	4.8	0.75	4	26	38		
		D, H				6.5	4.9	0.71		26	38		
		A, C	Carbon Steel & Stainless Steel		3.3	2.2	4.4	N/A			18	30	
		E			6.9	13.8	N/A			23	35		
		F		7.3	14.5	6.0	4.8	0.75	4	33	45		
		G				6.5	5.0	0.75	8	37	49		
2.5"	S	A, C	Cast Iron	2.9	2.5	5.0	N/A			19	31		
		B		3.1	3.8	7.5	7.0	5.5	0.75	4	30	42	
		D					7.3	5.7	0.71		30	42	
3"	S	A, C	Cast Iron	3.0	2.6	5.2	N/A			20	32		

**Flow Capacity:**  
S - Standard  
C - CP Body Construction

**Body Connection:**  
A - NPT  
B - ANSI Flanged (ISO 7005 PN20)  
C - ISO 7-1 Threaded

D - DIN PN16 Flanged  
E - Socket Welded Nipple  
F - Socket Welded Nipple w/ Class150 Flange (ISO 7005 PN20)  
G - Socket Welded Nipple w/ Class 300 Flange (ISO 7005 PN50)  
H - EN1092-1 PN16 (ISO 7005-1 PN16)

Series 8100 actuator: .75" (DN20) to 3" (DN80)

- 1) 1/8" NPT air inlet connection
- 2) Visual indication of valve position
- 3) Air exhaust - do not block
- 4) 2x 3/4" conduit connection
- 5) 2x 1/4" NPT test connection

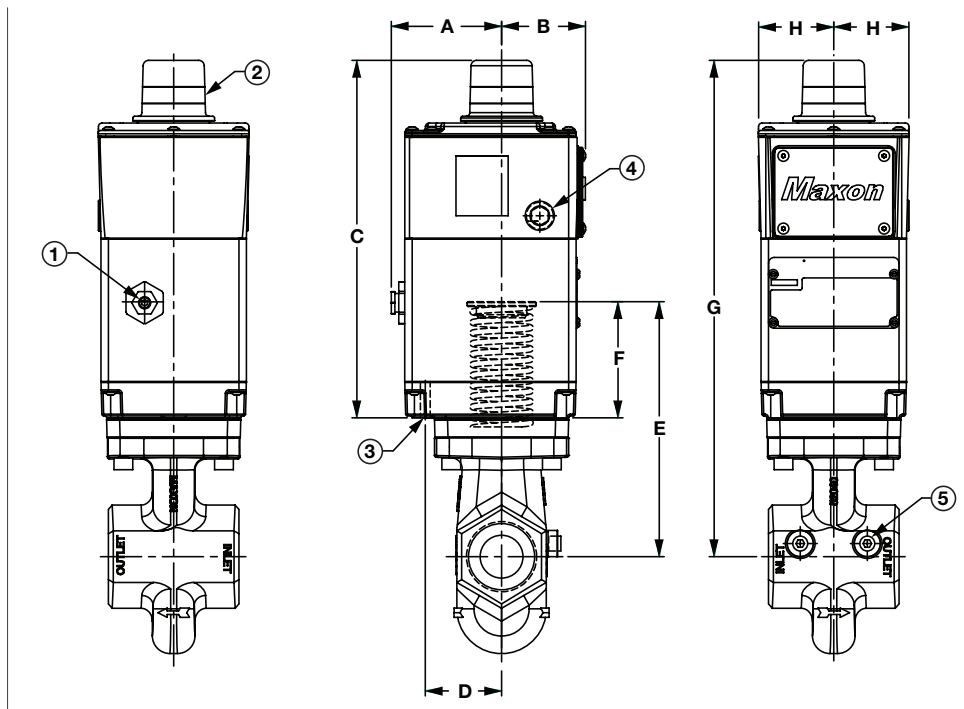

Valve Size	Approximate dimensions (inches)							
	A	B	C	D	E	F	G	H
.75"	3.5	2.8	12	2.6	7	4	15	2.5
1"					8		16	
1.25"					9		17	
1.5"								
2"								
2.5"								
3"								

Series 8000 valve body: 2.5" CP (DN65), 3" CP (DN80), 4" CP (DN100)

1) 2x 1/4" NPT test connection

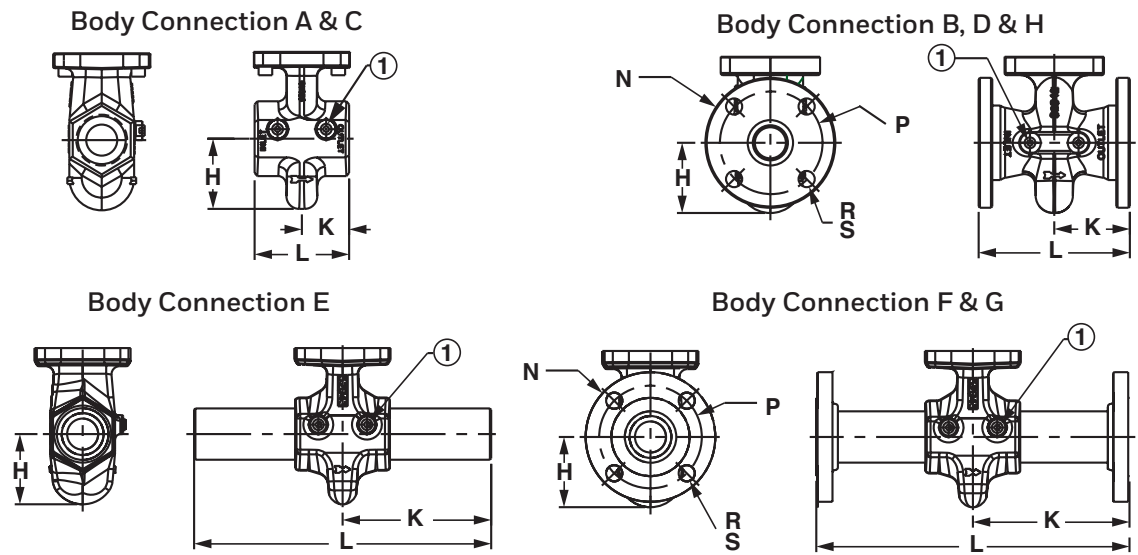

Valve Size	Flow Capacity	Body Connection	Body/ Bonnet Material	Approximate Dimensions (inches)						Approximate Weight (lbs)			
				H	K	L	N Ø	P Ø	R Ø	S # of holes	Body Assembly	Actuator Assembly	Total Weight
2.5"	C	A, C	Cast Iron	4.3	2.5	5.0	N/A				19	13	32
		B		4.5	3.8	7.5	7.0	5.5	0.75	4	31		44
		D					7.3	5.7	0.75	8	31		44
		H	7.3				5.7	0.75	8	31	44		
		B	Carbon Steel & Stainless Steel	7.0	5.5	0.75	4	34	47				
		D		7.3	5.7	0.71	8	34	47				
	H	7.3		5.7	0.71	8	30	43					
C	G	CS & SS	4.4	6.1	12.3	7.5	5.9	0.88	8	39	51		
3"	C	A, C	Cast Iron	5.1	2.8	5.5	N/A				24	37	
		B		5.2	4.0	8.0	7.5	6.0	0.75	4	46	59	
		D, H	7.9				6.3	0.75	8	46	59		
		B	Carbon Steel & Stainless Steel	7.5	6.0	0.75	4	47	60				
	D, H	7.9		6.3	0.71	8	47	60					
	C	G	CS & SS	5.2	6.6	13.3	8.3	6.6	0.88	8	56	68	
4"	C	B	Cast Iron	5.5	4.5	9.0	9.0	7.5	0.75	8	64	77	
		D, H					8.7	7.1	0.75		64	77	
		B	Carbon Steel & Stainless Steel				9.0	7.5	0.75		64	77	
		D, H					8.7	7.1	0.71		64	77	
	C	G	CS & SS	5.1	7.4	15.3	10	7.9	0.88	8	83	96	

**Flow Capacity:**

S - Standard  
C - CP Body Construction

**Body Connection**

A - NPT  
B - ANSI Flanged (ISO 7005 PN20)  
C - ISO 7-1 Threaded D - DIN PN16 Flanged  
E - Socket Welded Nipple  
F - Socket Welded Nipple w/ Class 150 Flange (ISO 7005 PN20)  
G - Socket Welded Nipple w/ Class 300 Flange (ISO 7005 PN50)  
H - EN1092-1 PN16 (ISO 7005-1 PN16)

Series 8000 actuator: 2.5" CP (DN65), 3" CP (DN80), 4" CP (DN100)

- 1) 1/8" NPT air inlet connection
- 2) Visual indication of valve position
- 3) Air exhaust - do not block
- 4) 2x 3/4" conduit connection
- 5) 2x 1/4" NPT test connection

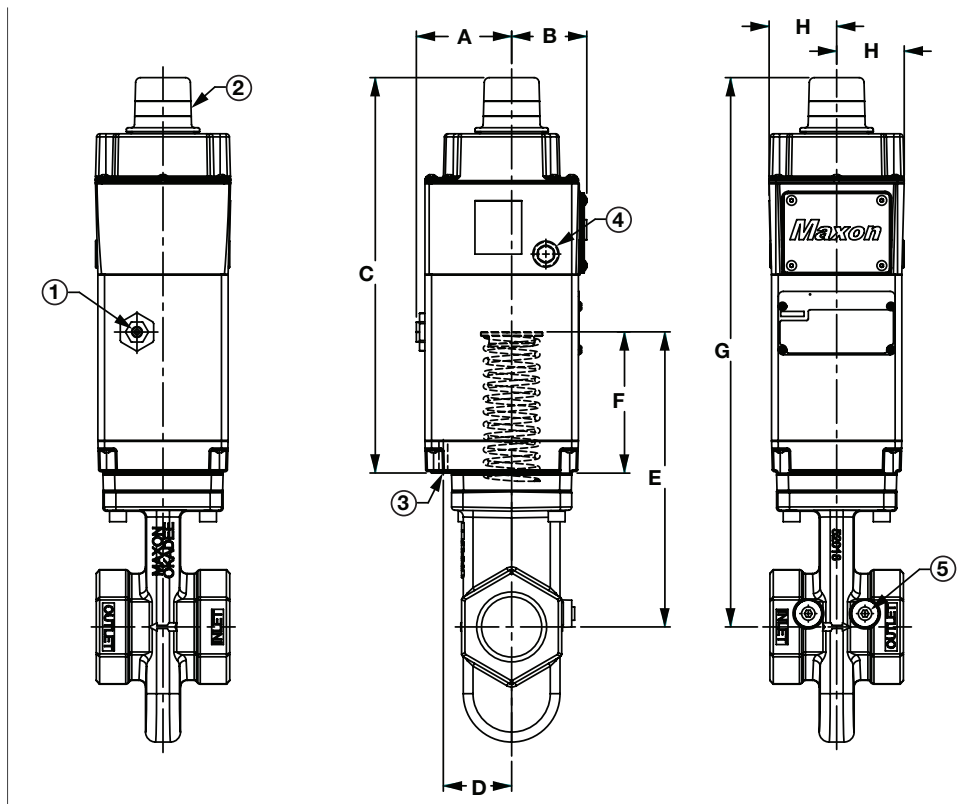

Valve Size	Flow Capacity	Approximate dimensions (inches)							
		A	B	C	D	E	F	G	H
2.5"	CP	3.5	2.8	14.8	2.6	11.1	5.3	20.6	2.5
3"	CP					11.8		21.3	
4"	CP					11.8		21.3	

Series 8100 valve body: 2.5" CP, 3" CP, 4" CP

1) 2x 1/4" NPT test connection

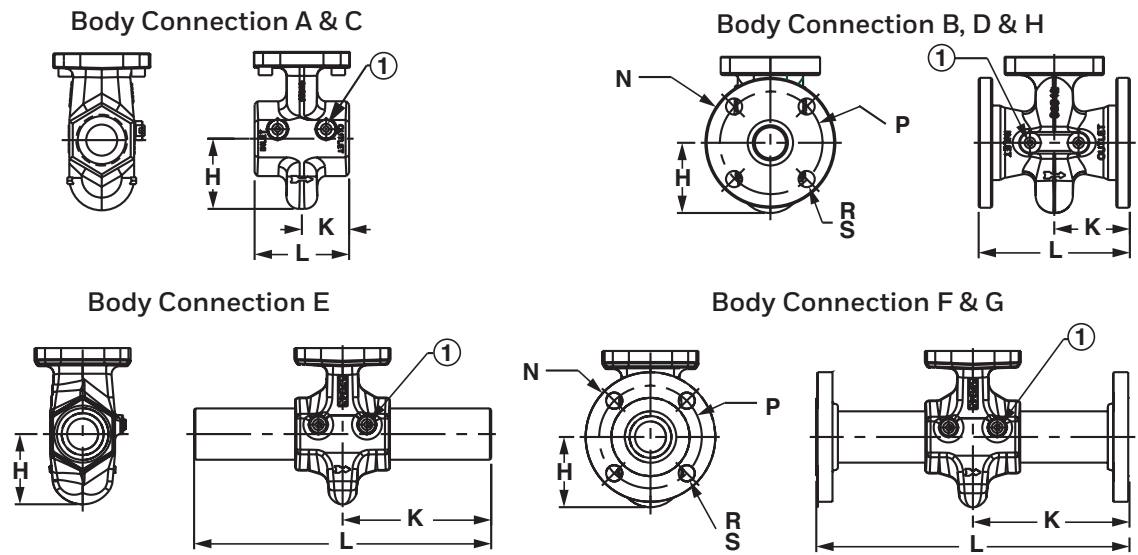

Valve Size	Flow Capacity	Body Connection	Body/ Bonnet Material	Approximate Dimensions (inches)						Approximate Weight (lbs)			
				H	K	L	N Ø	P Ø	R Ø	S # of holes	Body Assembly	Actuator Assembly	Total Weight
2.5"	C	A, C	Cast Iron	4.3	2.5	5.0	N/A				19	13	32
		B		4.5	3.8	7.5	7.0	5.5	0.75	4	31		44
		D					7.3	5.7	0.75	8	31		44
		H	7.3				5.7	0.75	8	31	44		
		B	Carbon Steel & Stainless Steel	7.0	5.5	0.75	4	34	47				
		D		7.3	5.7	0.71	8	34	47				
	H	7.3		5.7	0.71	8	34	43					
C	G	CS & SS	4.4	6.1	12.3	7.5	5.9	0.88	8	39	51		
3"	C	A, C	Cast Iron	5.1	2.8	5.5	N/A				27	37	
		B		5.2	4.0	8.0	7.5	6.0	0.75	4	48	59	
		D, H	7.9				6.3	0.75	8	48	59		
		B	Carbon Steel & Stainless Steel				7.5	6.0	0.75	4	49	60	
		D, H		7.9	6.3	0.71	8	49	60				
	C	G	CS & SS	5.2	6.6	13.3	8.3	6.6	0.88	8	56	68	
4"	C	B	Cast Iron	5.5	4.5	9.0	9.0	7.5	0.75	8	66	77	
		D, H					8.7	7.1	0.75		66	77	
		B	Carbon Steel & Stainless Steel				9.0	7.5	0.75		67	77	
		D, H					8.7	7.1	0.71		67	77	
	C	G	CS & SS	5.1	7.4	15.3	10	7.9	0.88	8	83	96	

**Flow Capacity:**

S - Standard  
C - CP Body Construction

**Body Connection:**

A - NPT  
B - ANSI Flanged (ISO 7005 PN20)  
C - ISO 7-1 Threaded D - DIN PN16 Flanged  
E - Socket Welded Nipples  
F - Socket Welded Nipples w/ Class 150 Flange (ISO 7005 PN20) G - Socket Welded Nipples w/ Class 300 Flange (ISO 7005 PN50) H - EN1092-1 PN16 (ISO 7005-1 PN16)



Series 8100 actuator: 2.5" CP, 3" CP, 4" CP

- 1) 1/8" NPT air inlet connection
- 2) Visual indication of valve position
- 3) 1/8" NPT air exhaust - do not block
- 4) 2x 3/4" conduit connection
- 5) 2x 1/4" NPT test connection

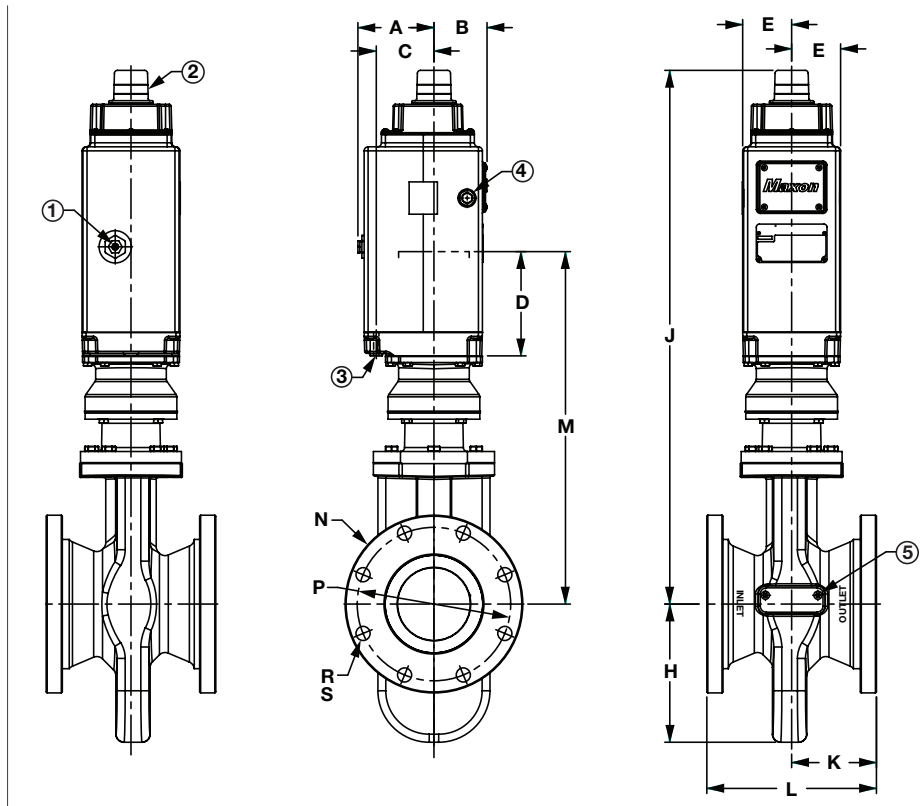

Valve Size	Flow Capacity	Approximate dimensions (inches)							
		A	B	C	D	E	F	G	H
2.5"	CP	4.5	3.3	16.3	3.6	12.2	6.4	22.1	3.0
3"	CP					12.9		22.8	
4"	CP								

Series 8000 and 8100: 6” and 8”

- 1) 1/8” NPT air inlet connection
- 2) Visual indication of valve position
- 3) Air exhaust - do not block
- 4) 2x 3/4” conduit connection
- 5) 2x 1/4” NPT test connection

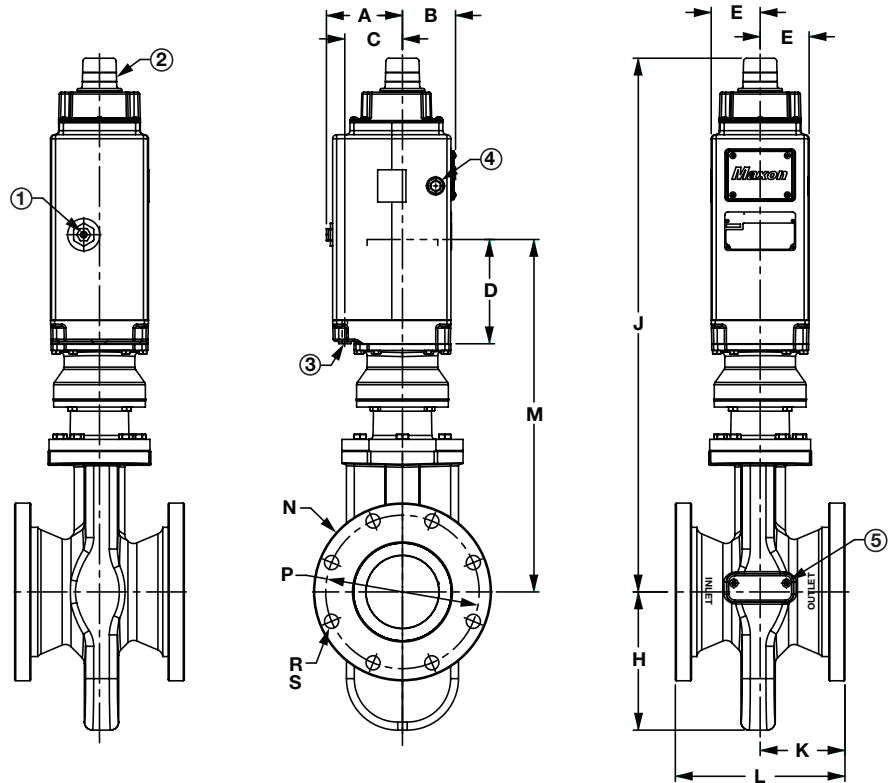

Valve Size	Flow Capacity	Body Conn.	Body/Bonnet Material	Approximate Dimensions (inches)													Approximate Weight (lbs)			
				A	B	C	D	E	H	J	K	L	M	N Ø	P Ø	R Ø	S # of holes	Body Assembly	Actuator Assembly	Total Weight
6"	S	B	Cast Iron	4.6	3.3	3.6	6.5	3.0	8.6	33.1	5.25	10.5	21.8	11.0	9.5	0.88	8	19	23	140
		D,H												11.2	9.5	0.86		31		140
		B	Carbon Steel & Stainless Steel											11.0	9.5	0.88		31		149
		D												11.2	9.5	0.86		31		149
8"	S	B	Carbon Steel & Stainless Steel	4.6	3.3	3.6	6.5	3.0	8.6	33.1	5.75	11.5	21.8	13.5	11.75	0.88	8	34	23	193
		D,H												13.38	11.61	0.86	12	34		193
		H												15.0	13.0	1.0	12	34		240

**Flow Capacity:**

S - Standard

**Body Connection:**

- B - ANSI 150 lbs (ISO7005 - PN20)
- D - DIN PN16 Flanged
- H - EN1092-1 PN16 (ISO 7005-1 PN16)
- J - ANSI Class 300 Flange (ISO 7005 PN50)

## ACCESSORIES

### SPEED CONTROL SET

Manually adjustable valve restricts flow to the actuator inlet and so reduces opening speed of the normally- closed shut-off valve or reduces the closing speed of normally-open vent valves.

- Available in carbon steel and stainless steel construction
- 90° mating elbow provided for easy assembly
- Tamper-proof set screw prevents accidental misadjustment



Carbon Steel construction



Stainless Steel construction

1) Speed control adjustment knob

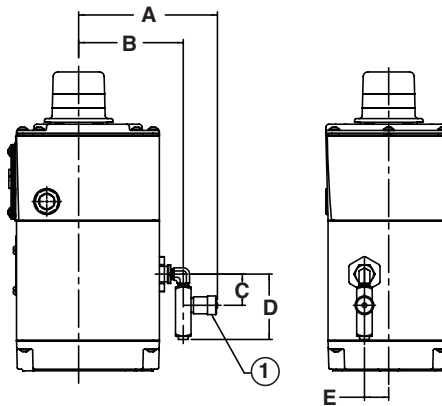

Speed Control Set	A	B	C	D	E
Carbon Steel	5.6	4.2	1.3	2.6	1.0
Stainless Steel	6.2	4.6	1.7	2.8	1.0

### EXTERNAL REDUNDANT SOLENOID WITH MANUAL RESET

Combination of both external redundant solenoids and manual reset option. If either solenoid trips, the valve will close and cannot be reset until it is done manually at the site of the valve before operations can resume.

- 1) Manual reset latching pin
- 2) Manual reset button
- 3) 1/8" NPT exhaust filter (do not block)
- 4) Speed control (optional)
- 5) Speed adjustment lock screw
- 6) Speed control adjustment knob
- 7) 1/8" NPT air inlet connection

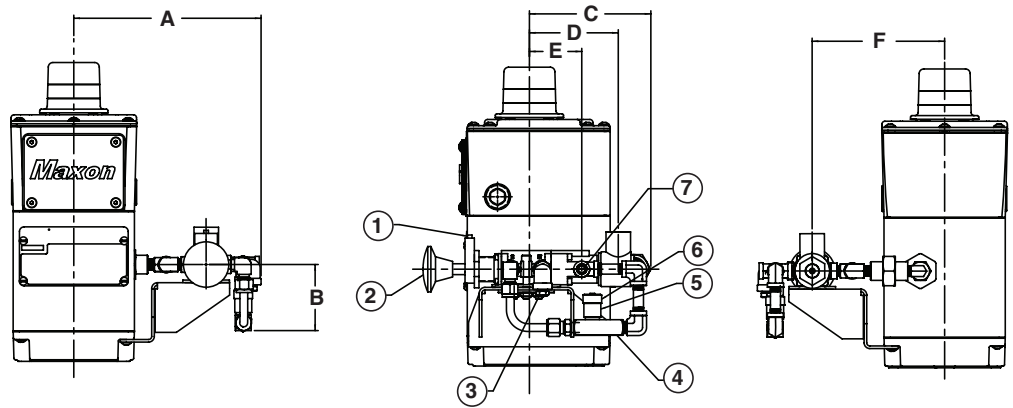

A	B	C	D	E	F
7.5	2.7	4.9	3.6	2.1	5.3

### EXTERNAL REDUNDANT SOLENOID

Dual shut-off solenoids provide additional SIL 2 certification levels to offer a higher level of protection against potential solenoid failure. The double redundant solenoid valve will automatically trip as a series shut-down mode and will close or open the valve (depending on set-up) if either of the solenoid valves trip.

#### General Purpose

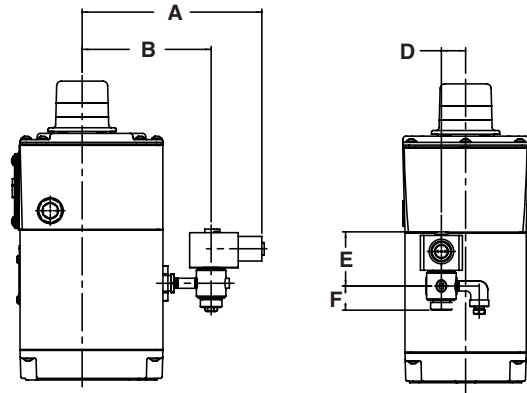

#### Intrinsically Safe

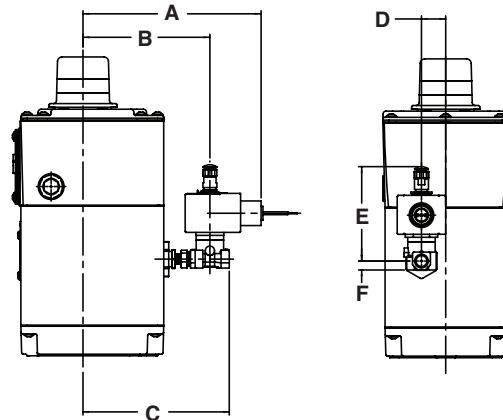

Solenoid type	A	B	C	D	E	F
General Purpose	7.2	5.2	---	1.0	2.2	1.0
Intrinsically Safe	7.2	5.1	5.9	1.0	3.8	0.4

### EXTERNAL REDUNDANT SOLENOID WITH SPEED CONTROL SET

Combination of both external redundant solenoids and speed control set option. If either solenoid trips, the valve will close and cannot be reset until it is done manually. Speed control set features manually adjustable valve that restricts flow to the actuator inlet and so reduces opening speed of the normally-closed shut-off valve or reduces the closing speed of normally-open vent valves.

#### General Purpose

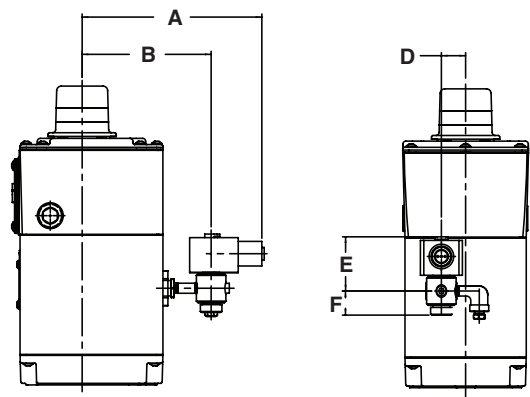

#### Intrinsically Safe

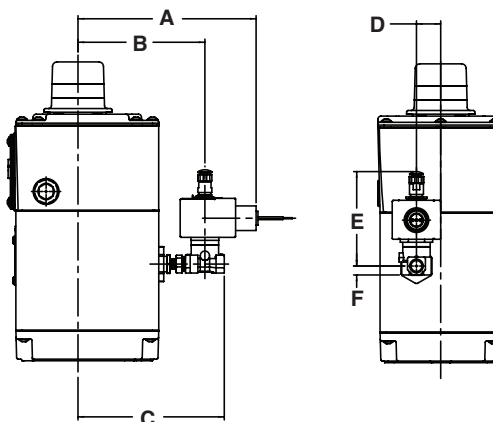

Solenoid type / speed control set type	A	B	C	D	E	F
General Purpose / carbon steel	5.2	2.2	2.7	1.1	1.0	0.5
General Purpose / stainless steel	5.2	2.2	2.8	1.1	1.0	0.5
Intrinsically Safe / stainless steel	5.1	---	2.8	1.7	1.0	---

### INTRINSIC SAFETY INTERFACES

Approved units interposed between the hazardous and safe area circuits limit parameters such as voltage, current or power.

- Suitable for use in Class I, Div. 2 areas
- DIN rail mounted
- Complements intrinsically safe Series 8000 Valves

Engineering recommendations for barriers and isolator option				
Manufacturer	IS interface type	Model no.	Application	MAXON no.
MTL	Zener Diode <sup>1</sup>	MTL 7728+	Solenoid	1067656
		MTL 7787+	Switch <sup>2</sup>	1067655
	Isolator <sup>3</sup>	MTL 5525	Solenoid	1067660
		MTL 5516C	Switch <sup>4</sup>	1067659

<sup>1</sup> Circuit must be isolated from earth in hazardous area

<sup>2</sup> Two barriers required for VOS1 / VCS1

<sup>3</sup> Circuit may be earthed at one point in hazardous area

<sup>4</sup> One barrier required for VOS1 / VCS1

## INSTALLATION, OPERATION AND MAINTENANCE INSTRUCTIONS

 ^ Please read the operating and mounting instructions before using the equipment. Install the equipment in compliance with the prevailing regulations.

 ^ Bedrijfs- en montagehandleiding voor gebruik goed lezen! Apparaat moet volgens de geldende voorschriften worden geïnstalleerd.

 ^ Lire les instructions de montage et de service avant utilisation! L'appareil doit impérativement être installé selon les réglementations en vigueur.

 ^ Betriebs- und Montageanleitung vor Gebrauch lesen! Gerät muß nach den geltenden Vorschriften installiert werden.

### European Sales Office

BELGIUM

MAXON International BVBA Luchthavenlaan 16-18

1800 Vilvoorde, Belgium

Tel: 32.2.255.09.09

Fax: 32.2.251.82.41

 **The Installation, Operating and Maintenance Instructions contain important information that must be read and followed by anyone operating or servicing this product. Do not operate or service this equipment unless the instructions have been read. IMPROPER INSTALLATION OR USE OF THIS PRODUCT COULD RESULT IN BODILY INJURY OR DEATH.**

### DESCRIPTION

The Series 8000 Valve is a pneumatically operated fuel shut-off valve. These valves require compressed air for actuation. The 8000 Series valve will open or close by the addition of a control voltage signal. Removal of the signal will cause a fast acting return to the at rest position. Options are available in both normally-closed and normally-open versions.

Series 8\*1\* Normally-Closed will shut off flow when de-energized and pass flow when energized.





Series 8\*2\* Normally-Open will shut off flow when energized and pass flow when de-energized.

The Series 8000 Valve has optional configurations that meet hazardous locations.

The Series 8000 Valve has fire safe trim configurations that meet API 6FA.

### NAMEPLATE AND ABBREVIATIONS

Consult the nameplate on your valve. This lists the maximum operating pressure, temperature limitations, voltage requirements and service conditions of your specific valve. Do not exceed nameplate ratings.

Abbreviation or Symbol	Description
M.O.P. or MOPD (PS)	Maximum Operating Pressure or Maximum Operating Pressure Differential
P <sub>ACT</sub>	Required actuator pressure
T <sub>S(AMB)</sub>	Ambient service temperature range
T <sub>S(FL)</sub>	Fluid service temperature range
	Visual indication determined by text, color and symbol; valve is shown in open position
	Visual indication determined by text, color and symbol; valve is shown in closed position
	Valve is shut
	Valve is partially open
	Valve is full open
VOS-1/2	Valve open switch(es)
VCS-1/2	Valve closed switch(es); proof of closure

## Component identification

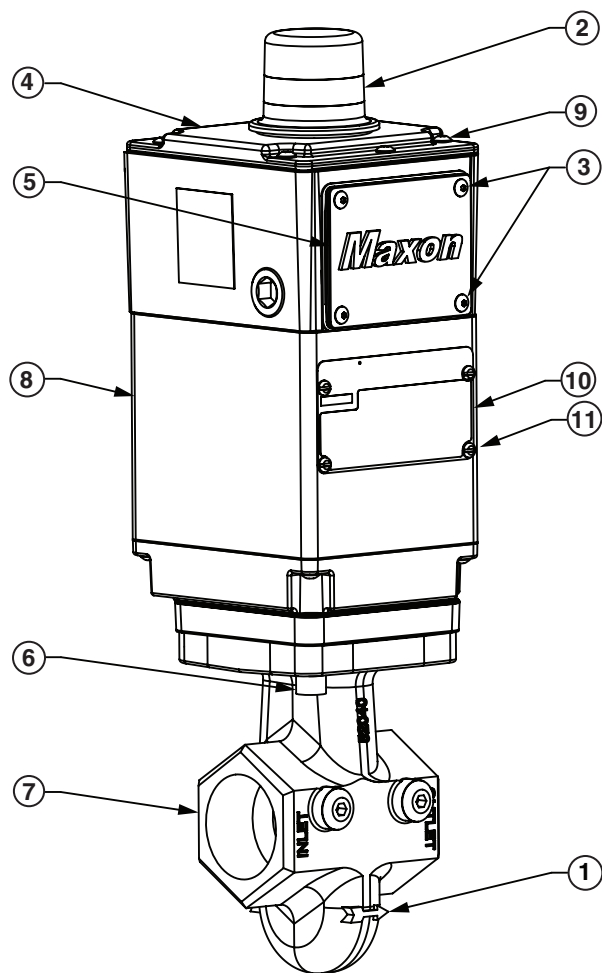

1)	Flow arrow
2)	Visual indication
3)	Terminal block cover screws, M5 x 12
4)	Switch access cover
5)	Terminal block cover
6)	Actuator bolts, M8 x 45 or M10 x 1.50
7)	Valve body
8)	Actuator
9)	Switch access cover screws, M6 x 20
10)	Nameplate
11)	Nameplate screws, M4 x 6

## Installation

1. A gas filter or strainer of 40 mesh (0.6 mm maximum) or greater is recommended in the fuel gas piping to protect the downstream safety shut-off valves.
2. Properly support and pipe the valve in the direction of the flow arrow on the valve body. Valve seats are directional. Sealing will be maintained at full rated pressures in one direction only. Sealing will be provided in reverse flow only at reduced pressures.
3. Series 8000 Valves require clean, dry compressed air or gas piped to the inlet of the actuator. Guidelines for various actuating gases:
  - A. Compressed Air
    - a. The vent, located on the underside of the base plate, should be protected from blockage or piped to a better location.
    - b. Although MAXON Series 8000 Valves do not require lubrication, they do contain Buna-N (-40°F) or silicone (-58°F) seals in the actuator sub-assembly. Compressed air supply must not contain any lubricant that is not compatible with Buna-N or silicone elastomers. MAXON recommends ISO 8573.1 class 3 for oil and particulates, and the dew point to be below the lowest end use temperature.
  - B. Natural gas and other fuel gases can be used to actuate the Series 8000 Valve when the appropriate considerations are taken into account.
    - a. Apply only the Intrinsically Safe Series 8000 Valve for the application. The general purpose and non-incendive options are not suitable for fuel gas activation.
    - b. The activating fuel gas must be clean and free of moisture. The Series 8000 actuator contains Buna-N elastomers and brass, aluminum and stainless steel components that will come in contact with the activating gas. The gas must not contain any constituents that are incompatible with these materials. Actuating gas must meet the quality stds mentioned above in section 3.A.b.
    - c. The exhaust gas must be vented to the atmosphere in a safe manner by piping from the filtered vent, located on the underside of the actuator's base. A 1/8" NPT female connection in the base plate allows for proper piping.
    - d. The use of fuel gases for actuation is not permitted in EC areas due to ATEX Zone 2 restrictions.

- e. Actuators for fuel gas activation are only rated from -40°F to 140°F.
  - C. For applications that are governed by the ATEX Directive (2014/34/EU), use of fuel gas activation is not acceptable.
4. In some instances, it may be desired to utilize a slow opening feature for either application or code-related reasons. If a slow opening feature is required for normally-closed shut-off valves, use MAXON's optional speed control set.
  5. Wire the valve in accordance with all applicable local and national codes and standards. In U.S. and Canada, wiring must conform to the NEC ANSI/NFPA 70 and/or CSA C22.1, Part 1.
    - A. Supply voltages must agree with valve's nameplate voltage within -15%/+10% for proper operation. For electrical wiring schematic, see instructions or sample affixed inside valve terminal block cover.
    - B. Grounding is achieved with a grounding screw, which is located in the top assembly.
    - C. Customer connections are provided via terminal block located in the top assembly.
    - D. Main power wiring (120 VAC or 240 VAC) must be segregated from lower voltage 24 VDC signal wiring, when both are required.
    - E. WARNING: For Division 2 installations using the intrinsically safe solenoid, the power source is not to exceed 28VDC with a minimum series resistance of 300 ohms.
  6. Maintain integrity of the Series 8000 actuator enclosure by using the appropriate electrical connectors for the (2) 3/4" NPT conduit threaded connections. The Series 8000 electrical enclosure is NEMA 4 and IP65 rated with an option for NEMA 4X.
    - A. To eliminate any potential for gas to enter the electrical wiring system, install a conduit seal fitting at the actuator conduit hub.
  7. All access cover plate screws should be tightened using an alternate cross-corner tightening pattern to the values shown in Table 1.
  8. Verify proper installation and operation by electrically actuating the valve for 10-15 cycles prior to the first introduction of gas.
  9. When customer-supplied, externally mounted solenoids are used, the component must be rated for the Class and Division, or Zone of the hazardous area.
  10. Do not test or use MAXON Gas Valves with liquids
    - A. MAXON Gas Valves are constructed for gas usage only, and any liquid used in the pipeline will collect in the valve body and can seriously affect function.

**Table 1 - Torque Specifications**

Item Number	Description	Torque
3	Terminal Block Cover Screws, M5 x 12	20 in-lbs
9	Switch Access Cover Screws, M6 x 20	20 in-lbs
6	Actuator Bolts, M8 x 45	13 ft-lbs
6	Actuator Bolts, M10 x 1.50	13 ft-lbs
11	Nameplate Screws, M4 x 6	10 in-lbs



## SPECIFICATIONS

Valve Body Assemblies									
Valve Size	Flow Capacity	Actuator Pressure Class	Body Connections Available <sup>1</sup>	Body Material	Cv Rating	Flow Rate <sup>2</sup> $\frac{\text{cfh}}{\text{m}^3 \text{ h}}$	MOP/MOPD $\frac{\text{psig}}{\text{bar}}$		
.75" (DN 20)	Std.	High Pressure	A, C	Iron	19	1060 / 30	200/13.8		
			A, C, E, F, G	Steel			255/17.6		
				Stainless					
1" (DN 25)	Std.	High Pressure	A, C	Iron	20	1115 / 31	200/13.8		
			A, C, E, F, G	Steel			255/17.6		
				Stainless					
1.25" (DN 32)	Std.	High Pressure	A, C	Iron	45	2510 / 71	200/13.8		
1.5" (DN 40)	Std.	High Pressure	A, C	Iron	53	2956 / 83	200/13.8		
			A, C, E, F, G	Steel			255/17.6		
				Stainless					
2" (DN 50)	Std.	High Pressure	A, B, C, D, H	Iron	86	4796 / 135	200/13.8		
			A, C, E, F, G	Steel			255/17.6		
				Stainless					
2.5" (DN 65)	Std.	High Pressure	A, B, C, D, H	Iron	127	7083 / 200	150/10.3		
			CP	Std			A, B, C, D, H	Iron	304
	B, D, H	Steel							
		High Pressure		A, B, C, D, H			Iron	175/12.1	
	B, D, H						Steel		
		Stainless							
3" (DN 80)	Std.		High Pressure	A, C	Iron	173	9648 / 273	150/10.3	
		CP		Std	A, B, C, D, H			Iron	423
	B, D, H		Steel						
			High Pressure	A, B, C, D, H	Iron			135/9.3	
	B, D, H				Steel				
		Stainless							
4" (DN 100)	CP		Std.	B, D, H	Iron	490	27328 / 773	40/2.7	
		High Pressure			Steel				
	Stainless								
	Iron		135/9.3						
	Steel								
	Stainless								
6" (DN 150)		Std.	B, D, H	Iron	1172	65364 / 1850	60/4.1		
	High Pressure			Steel					
		Stainless							
		Iron		100/6.9					
		Steel							
	Stainless								
8" (DN 200)		Std.	B, D, H, J	Steel	1320	73406 / 2078	60/4.1		
	High Pressure			Stainless					
		Steel		100/6.9					
		Stainless							
		Stainless							

**1 Body Connections**

A - NPT  
 B - ANSI 150 lb Flange (ISO 7005 PN 20)  
 C - ISO Threaded  
 D - DIN PN16 Flange

E - Socket Welded Nipple  
 F - Socket Welded Nipple w/ANSI 150 lb flange (ISO 7005 PN20)  
 G - Socket Welded Nipple w/ANSI 300 lb flange (ISO 7005 PN50)  
 H - EN 1092-1 PN16 (ISO 7005-1 PN16)  
 J - ANSI Class 300 Flange (ISO 7005 PN50)

**<sup>2</sup> Flow for Natural Gas (S.G. 0.60) at differential pressure = 1" wc and standard temperature (68°F) and pressure (14.696 psi)**

**OPERATING CHARACTERISTICS**

- Opening time varies with valve size, air pressure, temperature, and fuel pressure. Typically about 3 seconds for larger sizes and down to approximately 1 second for smaller valves. For slower opening, a speed control set can be supplied by MAXON.

- Closing time is less than 1 second for all sizes, regardless of application parameters.
- Recommended Construction Options for Common Types of Gas

Gas	Gas Code	Suggested Material Options			MOPD Rating	Agency Approvals and Certifications			
		Seals & Bumper	Body & Bonnet <sup>7</sup>	Trim Option <sup>5</sup>		FM	CSA <sup>3</sup>	CE <sup>4</sup>	
								GAD <sup>6</sup>	PED <sup>7</sup>
Air	AIR	A, B, C, F	1, 2, 5, 6	1, 2, 3, 6, 7	Std.	X	X		X
Ammonia	AMM	A, C, F	1, 2, 5, 6	1, 2, 3, 6, 7	Std.	X			X
Butane Gas	BUT	A, B, F	1, 2, 5, 6	1, 2, 3, 6, 7	Std.	X	X	X	X
Coke Oven Gas	COKE	B, F	5	Analysis Required	Std.	X			X
Digester <sup>1</sup>	DIG	Analysis Required	5	Analysis Required	Std.	X			X
Endothermic AGA	ENDO	A, B, F	1, 2, 5, 6	1, 2, 3, 6, 7	Std.	X	X		X
Exothermic Gas	EXO	A, B, F	1, 2, 5, 6	1, 2, 3, 6, 7	Std.	X	X		X
Hydrogen Gas	HYD	A, B, C, F	1, 2, 5, 6	1, 2, 3, 6, 7	Reduced <sup>2</sup>	X			X
Manufactured <sup>1</sup>	MFGD	Analysis Required	5	Analysis Required	Std.	X	X		X
Natural Gas	NAT	A, B, F	1, 2, 5, 6	1, 2, 3, 6, 7	Std.	X	X	X	X
Nitrogen	NIT	A, B, C, F	1, 2, 5, 6	1, 2, 3, 6, 7	Std.	X	X		X
Oxygen (High P)	OXYH	B, C, F	2, 5, 6	4, 5	200 psig	X			X
Oxygen (Low P)	OXYL	B, C, F	1, 2, 5, 6	4, 5	30 psig	X			X
Oxygen X	OXYX	B, C, F	2, 5, 6	4, 5	Std.	X			X
Propane	PROP	A, B, F	1, 2, 5, 6	1, 2, 3, 6, 7	Std.	X	X	X	X
Refinery <sup>1</sup>	REF	Analysis Required	5	Analysis Required	Std.	X			X
Sour Natural Gas <sup>1</sup>	SOUR	Analysis Required	5	Analysis Required	Std.	X			X
Town Gas <sup>1</sup>	TOWN	Analysis Required	5	Analysis Required	Std.	X	X	X	X
Land Fill Gas <sup>1</sup>	LAND	Analysis Required	5	Analysis Required	Std.	X			X

**Notes:**

<sup>1</sup> Other body and trim packages may be acceptable pending fuel analysis. For pricing inquiries, Viton or Omniflex o-rings should be used. Contact MAXON for details.

<sup>2</sup> Valve maximum operating pressure differential (MOPD) to be reduced by 25% from standard ratings.

<sup>3</sup> ISO connections are not recognized by CSA or UL standards.

<sup>4</sup> 8000 Series electro-pneumatic valves meet the essential requirements of the Low Voltage - LVD (2014/35/EU), Gas Appliances - GAR (2009/142/EC), and Pressure Equipment - PED (2014/68/EU) Directives.

<sup>5</sup> Trim Option 1 is only allowed with Body and Bonnet Option 1.

<sup>6</sup> The Gas Appliance Regulation only covers the use of commercially available fuels (natural gas, butane, town gas and propane).

<sup>7</sup> PED certification limited to 1-1/2" through 4" valves with steel or stainless steel body options (2, 5, 6). Body option 2 has a min ambient temp of -20°F.

**Body Seals:**

A - Buna-N B - Viton  
C - Ethylene Propylene  
F - Omniflex

**Body & Bonnet:**

1 - Cast Iron  
2 - Carbon Steel  
5 - Stainless Steel  
6 - Low Temp Carbon Steel

**Trim Package:**

1 - Trim Package 1  
2 - Trim Package 2  
3 - Trim Package 3 (NACE)  
4 - Trim Package 2, Oxy Clean  
5 - Trim Package 3, Oxy Clean  
6 - Trim 2 fire safe  
7 - Trim 3 fire safe

**AUXILIARY FEATURES**











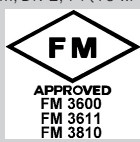









- Non-adjustable Proof of Closure Switch(es) with valve seal over travel interlock.
- Auxiliary switch for indication of full travel (open for normally-closed valves, closed for normally-open valves).





**OPERATING ENVIRONMENT**

- Fluid temperature range of -40°F to 212°F , with options available for -58°F to 212°F.
- Actuators are rated for NEMA 4, IP65 or optional NEMA 4X, IP65.
- Ambient temperature range of -40°F to 140°F for the 8011, 8111, 8021 and 8121 General Purpose and 8012, 8112, 8022 and 8122 Non-Incendive series valves; option of -58°F to 140°F also available. Intrinsically safe coil option on the Non-Incendive valves, is -40°F to 122°F. Low temp option -58°F to 122°F also available.
- Ambient temperature range of -40°F to 122°F for 8013, 8113, 8023 and 8123 Intrinsically Safe series valves; option of -58°F to 122°F also available.
- All valves for oxygen service or using Ethylene Propylene body seals are limited to a minimum ambient and fluid temperature of 0°F.

# AGENCY APPROVALS AND CERTIFICATIONS

(Will vary with specific options selected)

	General Purpose Valves 8111, 8121, 8011, 8021 Series		Non-Incendive/Non-Sparking Valves 8112, 8122, 8012, 8022 Series		Intrinsically Safe Valves 8113, 8123, 8013, 8023 Series	
	Standards	Markings	Standards	Markings	Standards	Markings
FM Approvals	FM 7400		FM 3611 FM 3600 FM 3810 NEMA 250 IIEC 60529	Class I, Div 2, Groups ABCD, T4 (T5 w/ IS coil) Class II, Div 2, Groups FG, T4 (T5 w/ IS coil) Class III, Div 2, T4 (T5 w/ IS coil) 	FM 3610 FM 3600 FM 3810 NEMA 250 IIEC 60529	Class I, Div 1, Groups ABCD, T5 Class II, Div 1, Groups EFG, T5 Class III, Div 1, T5 
CSA/SIRA Approvals-IECEX Certification	Not Applicable	None	IEC 60079-0 IEC 60079-15 IEC 60079-31	IECEX SIR 19.0017X Ex nA nC IIC T4 Gc (T5 w/ IS coil) -40°C ≤ Ta ≤ 60°C (50°C max w/ IS coil) Ex tc IIIC T135°C Dc IP65	IEC 60079-0 IEC 60079-11	IECEX SIR 19.0017X Ex ia IIC T5 Gb Ex tc IIIC T135°C Dc -50°C ≤ Ta ≤ 50°C
CSA International	CSA 6.5 - 2015	 	CSA Std. C22.2: No. 0-M91 No. 25-1966 No. 94-M91 No. 213-M1987 CAN/CSA-E60079-0 CAN/CSA-E60079-15 IEC 60529	Class I, Div 2, Groups ABCD, T4 Class II, Div 2, Groups FG, T4 Class III, Div 2, T4 Ex nA IIC T4 Ta = 60C (w/ std coil) Ex nA IIC T5 Ta = 50C (w/ IS coil) (Zone 2 approval)  	CSA Std. C22.2: No. 0-M91 No. 25-1966 No. 94-M91 No. 157-M1992 CAN/CSA-E60079-0 CAN/CSA-E60079-11 IEC 60529	Class I, Div 1, Groups ABCD, T5 Class II, Div 1, Groups EFG, T5 Class III, Div 1, T5 Ex ia IIC T5, -50°C ≤ Ta ≤ 50°C (Zone 0 Approval)  
United Kingdom GAR, LVD Compliance <sup>1</sup>	BS EN 161 BS EN 13774		BS EN 161 BS EN 13774		BS EN 161 BS EN 13774	
European GAR, LVD Compliance <sup>1</sup>	EN 161 EN 13774		EN 161 EN 13774		EN 161 EN 13774	
United Kingdom Approvals (Hazardous Locations) <sup>2</sup>	Not Applicable	None	Not Applicable	None	BS EN 60079-0 BS EN 60079-11 BS EN 60529+A1 BS EN 13463-1 BS EN 13463-5	Sira 19ATEX2040X II 2GD Ex ia IIC T5 Gb Ex ia IIIC T100°C Db Ta = -50°C to +50°C IP65  
European Approvals (Hazardous Locations) <sup>2</sup>	Not Applicable	None	Not Applicable	None	EN 60079-0 EN 60079-11 EN 60529+A1 EN 13463-1 EN 13463-5	Sira 19ATEX2040X II 2GD Ex ia IIC T5 Gb Ex ia IIIC T100°C Db Ta = -50°C to +50°C IP65  
United Kingdom PED Compliance <sup>1</sup>						
European PED Compliance <sup>1</sup>						
IEC Approvals	IEC 61010-1 IEC 61508	None	IEC 61010-1 IEC 61508	None	IEC 61010-1 IEC 61508	None
NCC/Inmetro	Not Applicable	None	ABNT NBR: IEC 60079-0 IEC 60079-15 IEC 60079-31	Ex nA nC IIC T4 Gc (T5 w/ I.S. Coil) Ex tc IIIC T135°C Dc IP65 -40°C ≤ Ta ≤ +60°C (+50°C w/ I.C. Coil)   Ex nA nC IIC T4 Gc -50°C ≤ Ta ≤ +60°C Ex nA nC IIC T5 Gc -50°C ≤ Ta ≤ +50°C Ex tc IIIC T135°C Dc IP65 Ex tc IIIC T135°C Dc IP65	ABNT NBR: IEC 60079-0 IEC 60079-11 IEC 60079-31	 Ex ia IIC T5 Gb -50°C ≤ Ta ≤ +50°C Ex tc IIIC T135°C Dc IP65
KTL	Not Applicable	None	Announcement No. 2010-36 of Ministry of Employment and Labor	Ex nA nC IIC T4 (-50°C ≤ Ta ≤ +60°C) 	Announcement No. 2010-36 of Ministry of Employment and Labor	Ex ia IIC T5 (-50°C ≤ Ta ≤ +50°C) 

	General Purpose Valves 8111, 8121, 8011, 8021 Series		Non-Incendive/Non-Sparking Valves 8112, 8122, 8012, 8022 Series		Intrinsically Safe Valves 8113, 8123, 8013, 8023 Series	
	Standards	Markings	Standards	Markings	Standards	Markings
<b>AGA Certifications</b>	AS 4629	None	AS 4629	None	AS 4629	None
<b>EAC Certifications</b>	RU C-BE. AM30.B.00711		Not Applicable	None	TP TC 012/2011 ГОСТ 31610.0-2014 (IEC 60079-0) ГОСТ 31610.11-2014 (IEC 60079-11) ГОСТ Р МЭК (IEC 60079-31)	 RU C-US.AЖ58.B.01684/21
<b>Chinese Approvals</b>	None	None	GB 3836.1 GB 3836.8 GB 12476.1 GB 12476.5	 Ex nA nC IIC T4 Gc (T5 w/ IS coil) -50°C < Ta < +60°C (+50°C w/ IS coil) Ex tD A22 IP65 T135°C	GB 3836.1 GB 3836.4 GB 12476.1 GB 12476.5	 Ex ia IIC T5 Gb -50°C < Ta < +50°C Ex tD A22 IP65 T135°C

<sup>1</sup> Product complies with the essential requirements of the following: Gas Appliance Regulation (EU) 2016/426, Low Voltage Directive (2014/35/EU), and Pressure Equipment Directive (2014/68/EU) up to 4"

<sup>2</sup> Product certified to meet the following: ATEX Directive 2014/34/EU Class A, Group 2 per EN 161

## VALVE CYCLE REQUIREMENTS

This is based on the standards that MAXON valves are approved to and the corresponding minimum number of cycles to be completed without failure as shown in the chart below.

	CSA (CSA 6.5)	FM (FM 7400)	European (EN161)
Automatic - Normally-Closed Series 8011, 8111, 8012, 8112, 8013, 8113	100,000	20,000	<= 1" 200,000 <= 3" 100,000 <= 8" 50,000
Vent Valves Series 8021, 8121, 8022, 8122, 8023, 8123	No special requirements	No special requirements	No special requirements

## ELECTRICAL DATA

### Normally-Closed Shut-Off Valves

#### GENERAL PURPOSE NORMALLY-CLOSED VALVES

Series 8011 & Series 8111 Switches: V7

Solenoid Valve: Standard

24 VDC, 4.8W

120VAC, 50/60 Hz, 11/9.4 VA Peak, 8.5/6.9 VA Holding

240VAC, 50/60 Hz, 11/9.4 VA Peak, 8.5/6.9 VA Holding

See page 15 (ELECTRICAL DATA) or inside valve cover for wiring schematic.

#### NON-INCENDIVE NORMALLY-CLOSED VALVES

Series 8012 & Series 8112 Switches: IP67

Solenoid Valve: Standard

24 VDC, 4.8W

120VAC, 50/60 Hz, 11/9.4 VA Peak, 8.5/6.9 VA Holding

240VAC, 50/60 Hz, 11/9.4 VA Peak, 8.5/6.9 VA Holding

24VDC IS, .09A, 2.1W

#### INTRINSICALLY SAFE NORMALLY-CLOSED VALVES

Series 8013 & Series 8113

Switches: V7 with optional IP67

Solenoid Valve: Intrinsically Safe

#### NOTES:

- 1) The Intrinsic Safety Entity concept allows the interconnection of two FM approved (CSA Certified when installed in Canada) Intrinsically safe devices with entity parameters not specifically examined in combination as a system when:  
 $V_{oc}$  or  $U_o$  or  $V_t \leq V_{max}$ ,  $I_{sc}$  or  $I_o$  or  $I_t \leq I_{max}$ ,  $C_a$  or  $C_o \geq C_i + C_{cable}$ ,  $L_a$  or  $L_o \geq L_i + L_{cable}$ , and for FM only:  $P_o \leq P_i$ .
- 2) Dust-tight conduit seal must be used when installed in Class II and Class III environments.
- 3) Control equipment connected to the Associated Apparatus must not use or generate more than 250 Vrms or Vdc.
- 4) Installation in the U.S. should be in accordance with ANSI/ISA RP12.06.01 "Installation of Intrinsically Safe Systems for Hazardous (Classified) Locations" and the National Electric Code® (ANSI/NFPA 70) Sections 504 and 505.
- 5) Installation in Canada should be in accordance with the Canadian Electrical Code, CSA C22.1, Part 1, Appendix F.
- 6) Installation in the European Union should be in accordance to Directive 2014/34/EU (ATEX).

- 7) The configuration of associated Apparatus must be FM Approved (CSA Certified when in Canada) under Entity Concept.
- 8) Associated Apparatus manufacturer's installation drawing must be followed when installing this equipment.
- 9) No revision to drawing without prior authorization from FM Approval and CSA International.

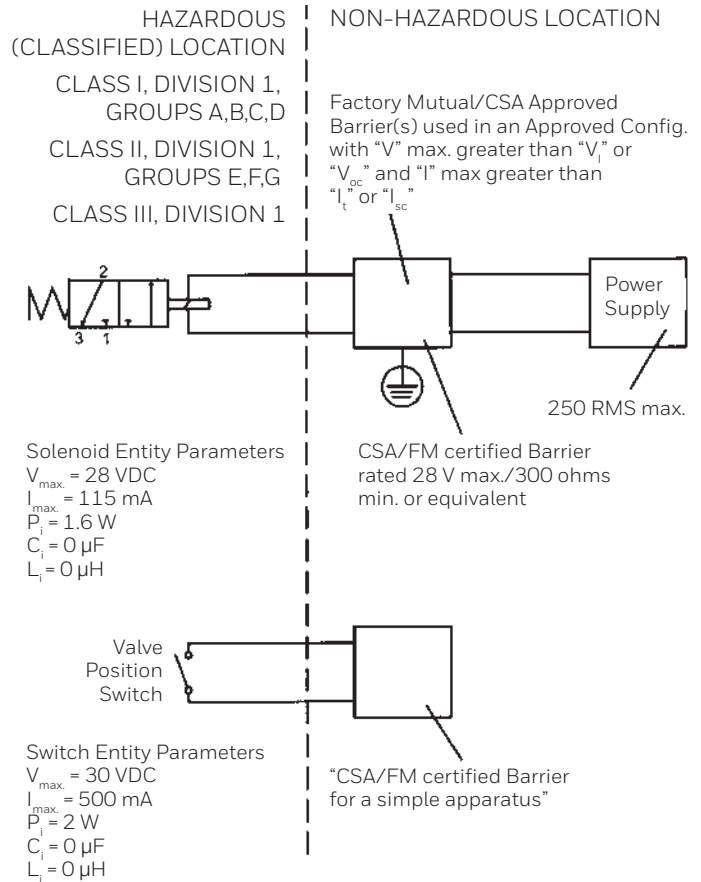

**INTRINSICALLY SAFE NORMALLY-CLOSED VALVES**

Series 8013 & Series 8113

Switches: V7 with optional IP67

Solenoid Valve: Customer-supplied, externally mounted

**NOTES:**

- 1) The Intrinsic Safety Entity concept allows the interconnection of two FM approved (CSA Certified when installed in Canada) Intrinsically safe devices with entity parameters not specifically examined in combination as a system when:  
 $V_{oc}$  or  $U_o$  or  $V_t \leq V_{max}$ ,  $I_{sc}$  or  $I_o$  or  $I_t \leq I_{max}$ ,  $C_a$  or  $C_o \geq C_i + C_{cable}$ ,  $L_a$  or  $L_o \geq L_i + L_{cable}$ , and for FM only:  $P_o \leq P_i$ .
- 2) Dust-tight conduit seal must be used when installed in Class II and Class III environments.
- 3) Control equipment connected to the Associated Apparatus must not use or generate more than the maximum permissible safe area voltage (Um) for the barrier.
- 4) Installation in the U.S. should be in accordance with ANSI/ISA RP12.06.01 "Installation of Intrinsically Safe Systems for Hazardous (Classified) Locations" and the National Electric Code® (ANSI/ NFPA 70) Sections 504 and 505.
- 5) Installation in Canada should be in accordance with the Canadian Electrical Code, CSA C22.1, Part 1, Appendix F.
- 6) Installation in the European Union should be in accordance to Directive 2014/34/EU (ATEX).
- 7) The configuration of associated Apparatus must be FM Approved (CSA Certified when in Canada) under Entity Concept.
- 8) Associated Apparatus manufacturer's installation drawing must be followed when installing this equipment.
- 9) No revision to drawing without prior authorization from FM Approval and CSA International.

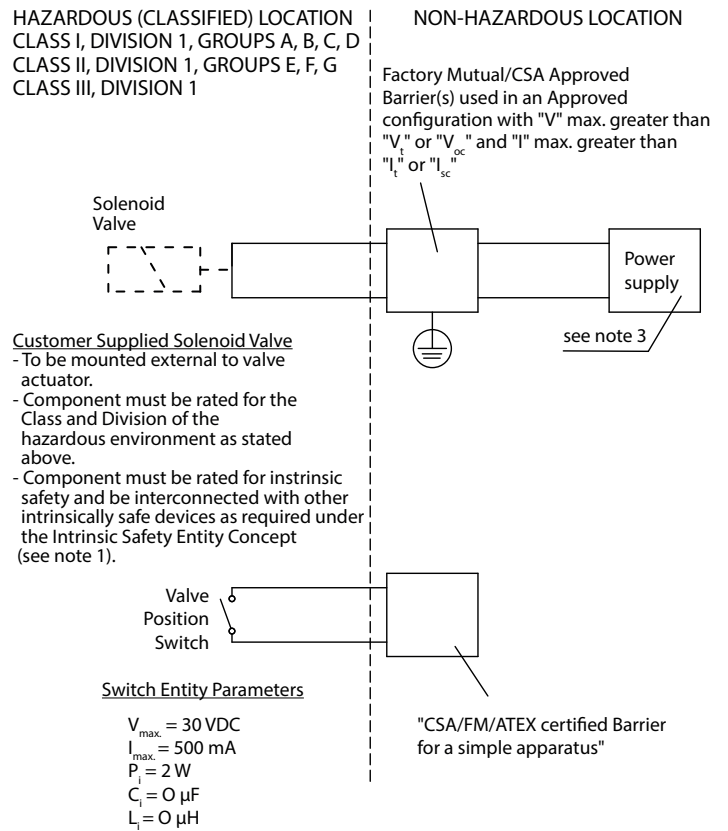

## Normally-Open Vent Valves

### GENERAL PURPOSE NORMALLY-OPEN VENT VALVES

Series 8021 & Series 8121 Switches: V7

Solenoid Valve: Standard

24 VDC, 4.8W

120VAC, 50/60 Hz, 11/9.4 VA Peak, 8.5/6.9 VA Holding

240VAC, 50/60 Hz, 11/9.4 VA Peak, 8.5/6.9 VA Holding

See page 15 (ELECTRICAL DATA) or inside valve cover for wiring schematic..

### NON-INCENDIVE NORMALLY-OPEN VENT VALVES

Series 8022 & Series 8122 Switches: IP67

Solenoid Valve: Standard

24 VDC, 4.8W

120VAC, 50/60 Hz, 11/9.4 VA Peak, 8.5/6.9 VA Holding

240VAC, 50/60 Hz, 11/9.4 VA Peak, 8.5/6.9 VA Holding

24VDC IS, .09A, 2.1W

### INTRINSICALLY SAFE NORMALLY-OPEN VENT VALVES

Series 8023 & Series 8123

Switches: V7 with optional IP67

Solenoid Valve: Intrinsically Safe

#### NOTES:

- 1) The Intrinsic Safety Entity concept allows the interconnection of two FM approved (CSA Certified when installed in Canada) Intrinsically safe devices with entity parameters not specifically examined in combination as a system when:

$$V_{oc} \text{ or } U_o \text{ or } V_t \leq V_{max}, I_{sc} \text{ or } I_o \text{ or } I_t \leq I_{max}, C_a \text{ or } C_o \geq C_i + C_{cable}, L_a \text{ or } L_o \geq L_i + L_{cable}, \text{ and for FM only: } P_o \leq P_i.$$

- 2) Dust-tight conduit seal must be used when installed in Class II and Class III environments.
- 3) Control equipment connected to the Associated Apparatus must not use or generate more than 250 Vrms or Vdc.
- 4) Installation in the U.S. should be in accordance with ANSI/ISA RP12.06.01 "Installation of Intrinsically Safe Systems for
- 5) Installation in Canada should be in accordance with the Canadian Electrical Code, CSA C22.1, Part 1, Appendix F.
- 6) Installation in the European Union should be in accordance to Directive 2014/34/EU (ATEX).
- 7) The configuration of associated Apparatus must be FM Approved (CSA Certified when in Canada) under Entity Concept.

- 8) Associated Apparatus manufacturer's installation drawing must be followed when installing this equipment.
- 9) No revision to drawing without prior authorization from FM Approval and CSA International.

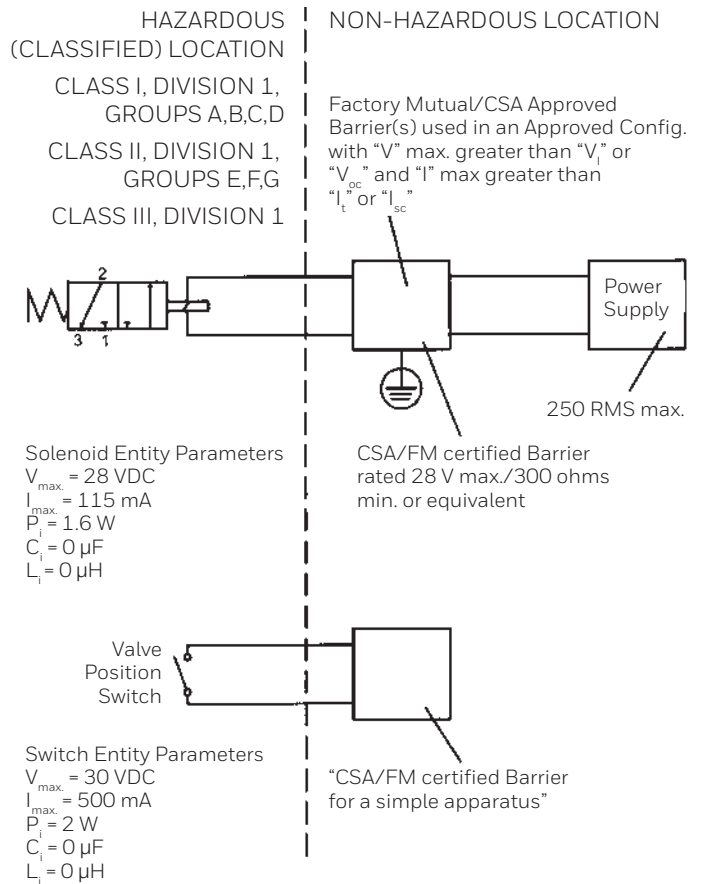



## INTRINSICALLY SAFE NORMALLY-OPEN VENT VALVES

Series 8023 & Series 8123

Switches: V7 with optional IP67

Solenoid Valve: Customer-supplied, externally mounted

### NOTES:

- 1) The Intrinsic Safety Entity concept allows the interconnection of two FM approved (CSA Certified when installed in Canada) Intrinsically safe devices with entity parameters not specifically examined in combination as a system when:  
 $V_{oc}$  or  $U_o$  or  $V_t \leq V_{max}$ ,  $I_{sc}$  or  $I_o$  or  $I_t \leq I_{max}$ ,  $C_a$  or  $C_o \geq C_i + C_{cable}$ ,  $L_a$  or  $L_o \geq L_i + L_{cable}$ , and for FM only:  $P_o \leq P_i$ .
- 2) Dust-tight conduit seal must be used when installed in Class II and Class III environments.
- 3) Control equipment connected to the Associated Apparatus must not use or generate more than the maximum permissible safe area voltage ( $U_m$ ) for the barrier.
- 4) Installation in the U.S. should be in accordance with ANSI/ISA RP12.06.01 "Installation of Intrinsically Safe Systems for Hazardous (Classified) Locations" and the National Electric Code® (ANSI/ NFPA 70) Sections 504 and 505.
- 5) Installation in Canada should be in accordance with the Canadian Electrical Code, CSA C22.1, Part 1, Appendix F.
- 6) Installation in the European Union should be in accordance to Directive 2014/34/EU (ATEX).
- 7) The configuration of associated Apparatus must be FM Approved (CSA Certified when in Canada) under Entity Concept.
- 8) Associated Apparatus manufacturer's installation drawing must be followed when installing this equipment.
- 9) No revision to drawing without prior authorization from FM Approval and CSA International.

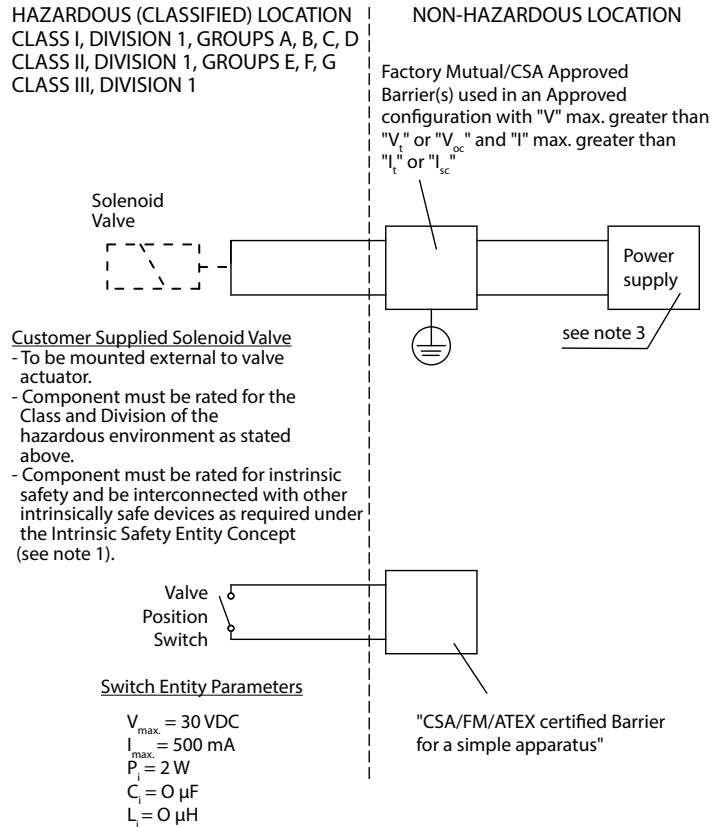

## OPERATING INSTRUCTIONS

Refer to appropriate catalog page for operating features applying to your specific valve. Never operate valve until all essential allied equipment is operative and any necessary purges completed. Failure of valve to operate normally indicates that it is not powered or supply air pressure is not adequate. Check this first!

Main system shut-off should always be accomplished with an upstream leak-tight manual fuel cock.



**The Series 8000 Pneumatic Safety Shut-off Valve is not intended to be used for end of line service.**

Users are responsible for providing protection against surface temperatures.

Users are responsible for providing suitable protective devices to protect against over pressure conditions.

Users are responsible for limiting momentary pressure surges to within 10% of the maximum allowed pressure in accordance with the Pressure Equipment Directive.

- Normally-closed shut-off valves begin opening cycle immediately upon being powered.
- Normally-open vent valves begin to close immediately upon being powered.

When installing three valves in a double block and bleed application, sequence the operation so that the bleed (vent) valve is closed (VCS indicates closed) prior to opening the blocking valves. This will minimize loss of fuel through the vent during the actuation cycle.

### ALTERNATE OPERATOR PRESSURES

Series 8000 Valves may be operated within a range of actuator pressures. Consult charts below for application fluid pressure and corresponding required actuator pressure.

**Pressure Required to Actuator  
Series 8100: .75"-3"**

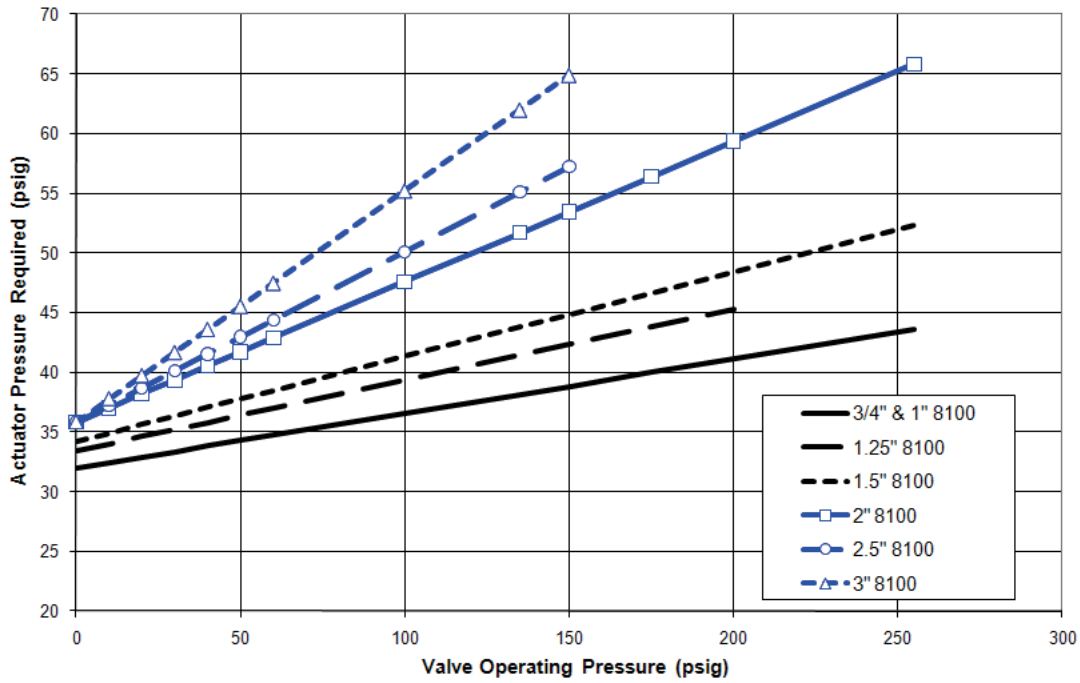

**Pressure Required to Actuator  
Series 8100: 2.5"CP, 3"CP, 4"CP**

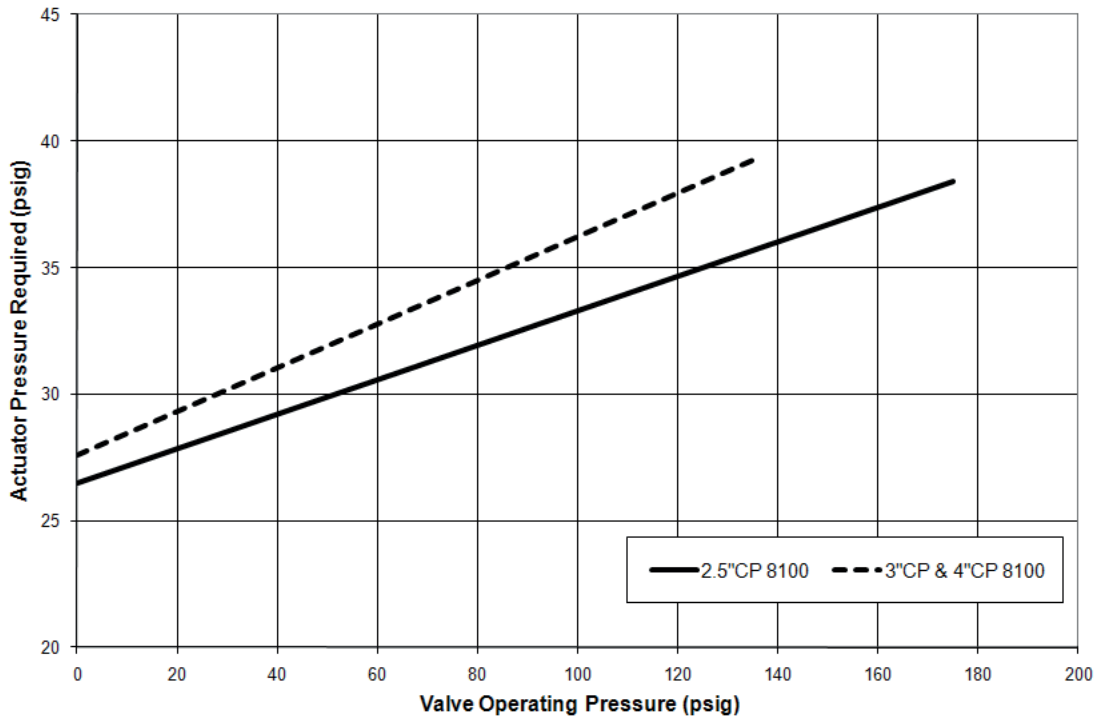

**Pressure Required to Actuator  
Series 8000: 2.5"CP, 3"CP, 4"CP**

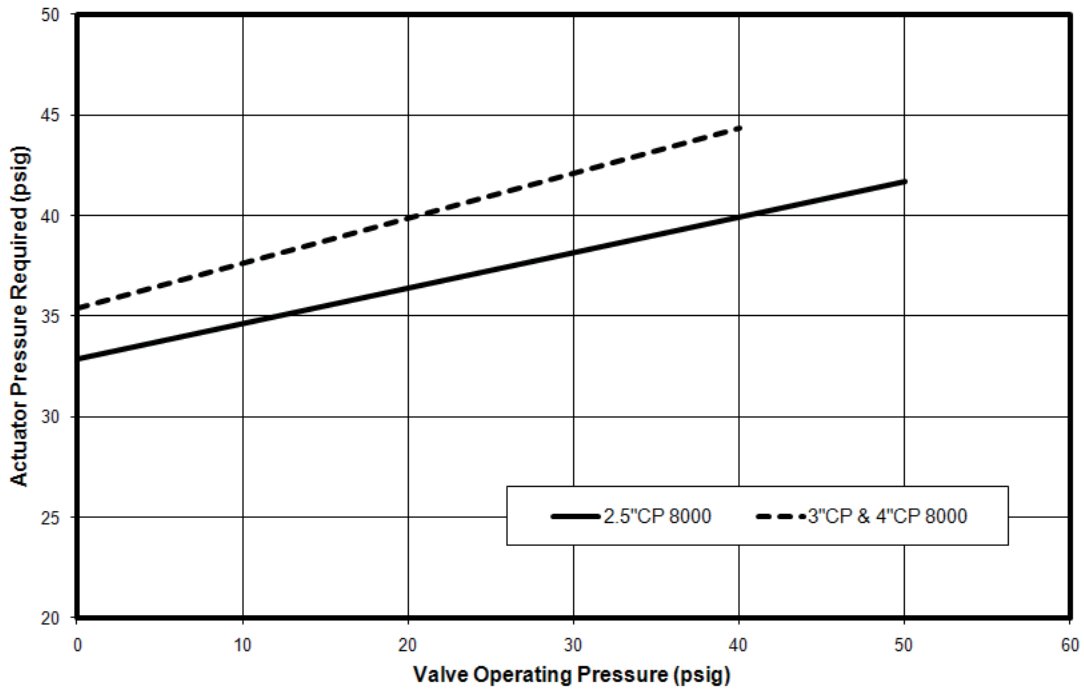

**Pressure Required to Actuator  
6" & 8" Series 8000 & 8100**

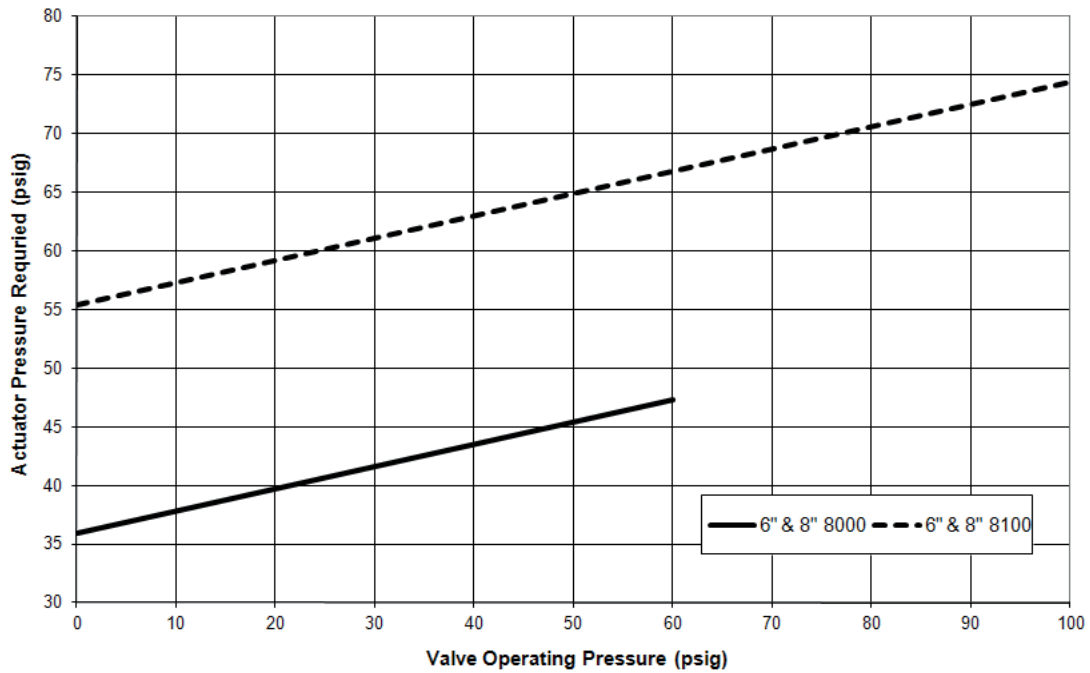

## MAINTENANCE INSTRUCTIONS

MAXON Series 8000 Valves are endurance tested far in excess of the most stringent requirements of the various approval agencies. They are designed for long life even if frequently cycled, and to be as maintenance-free and trouble-free as possible.

A valve operational test should be performed on an annual basis. If abnormal opening or closing is observed, the valve should be removed from service and your MAXON representative should be contacted. (See [Valve Technical Data page 10-35.1](#).)

Valve leak test should be performed on an annual basis to assure continued safe and reliable operation. Every MAXON valve is operationally tested and meets the requirements of FCI 70-2 Class VI Seat Leakage when in good operable condition. Zero leakage may not be obtained in the field after it has been in service. For specific recommendations on leak test procedures, see MAXON [Valve Technical Data page 10-35.2](#). Any valve that exceeds the allowable leakage, as set forth by your local codes or insurance requirements, should be removed from service and your MAXON representative should be contacted.

**Actuator assembly components require no field lubrication** and should **never** be oiled.

Auxiliary switches, solenoids or complete actuator may be replaced in the field.



**Do not attempt field repair of valve body or actuator. Any alterations void all warranties and can create potentially hazardous situations.**

If foreign material or corrosive substances are present in the fuel line, it will be necessary to inspect the valve to make certain it is operating properly. If abnormal opening or closing is observed, the valve should be removed from service. Contact your MAXON representative for instructions.

Operator should be aware of and observe characteristic opening/closing action of the valve. Should operation ever become sluggish, remove valve from service and contact MAXON for recommendations.



**Specific conditions of use:**

**This equipment includes some external non-metallic parts, including the outer protective coating. The user shall therefore ensure that the equipment is not installed in a location where it may be subjected to external conditions (such as high-pressure steam) which might cause a build-up of electrostatic charges on non-conducting surfaces. Additionally, cleaning of the equipment should be done only with a damp cloth.**

**Address inquiries to MAXON.** Local worldwide offices may be located at [www.maxoncorp.com](http://www.maxoncorp.com) or by phoning 011-765-284-3304.

Include valve serial number and nameplate information.

### Solenoid replacement procedure

- All power sources, both pneumatic and electric, must be de-energized and follow all proper safety procedures prior to servicing valve.
- Use a 4 mm allen wrench to remove the top plate. A 3 mm allen wrench is used to remove the terminal block cover.
- Use a 5/16" open end wrench to hold the cylinder shaft, then use a pair of pliers to unthread the switch indicator from the cylinder shaft. When using pliers, grab the indicator from the top.

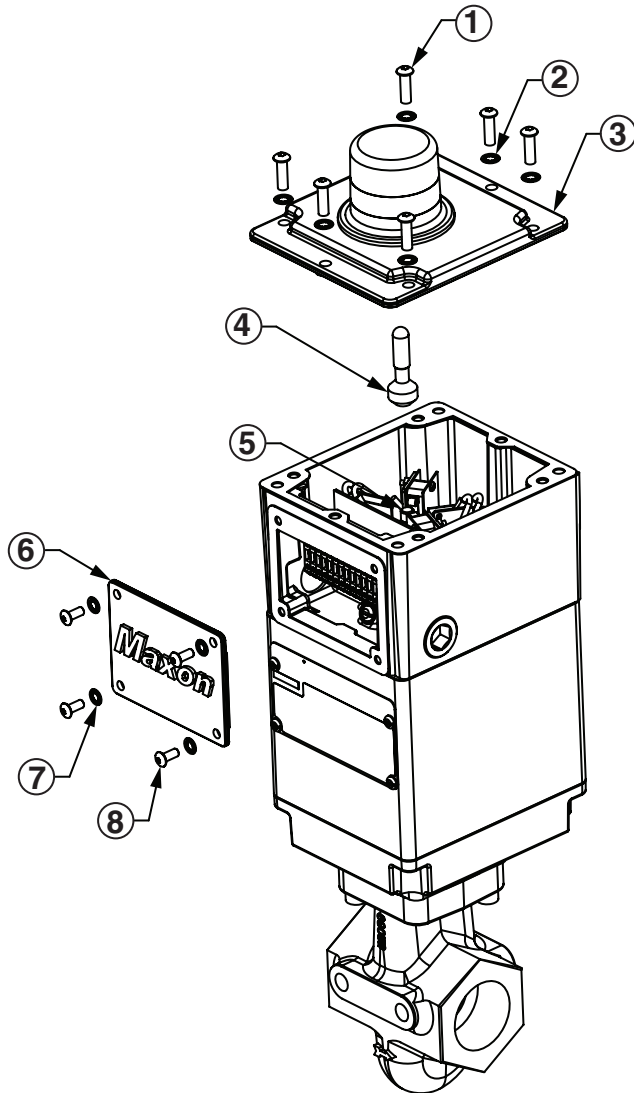

1)	Top plate screw M6 x 20 socket head cap screw
2)	M6 Lock washer
3)	Top plate
4)	Switch indicator
5)	Cylinder shaft
6)	Terminal block cover
7)	M5 Lock washer
8)	Terminal block cover screw M5 x 12 socket head cap screw

- Loosen the liquid tight connector nut where the solenoid wires come into the top housing. Remove #1 and #2 wire from the terminal block.

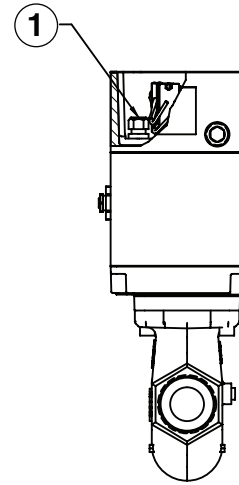

1) Liquid tight connector

- Use a 3/4" wrench to remove the solenoid inlet fitting. An adjustable wrench is used to loosen the housing collar. Slightly loosen the housing collar but do not remove, due to the nut and o-ring located inside the housing becoming dislocated.

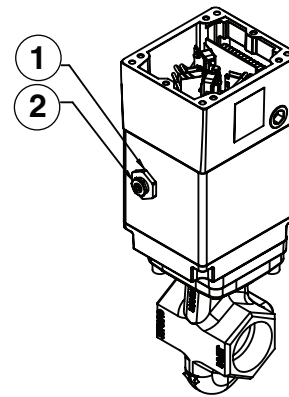

1) Housing collar  
2) Solenoid inlet fitting

- Use a 4 mm allen wrench and remove the 4 screws that hold the housing to the base plate. Pull the housing straight up and remove. Old solenoid wires will pass through liquid tight connector.

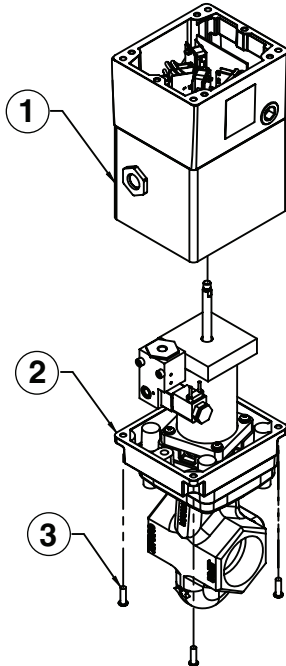

1)	Housing
2)	Base plate
3)	Housing screws M6 x 20 cap screws

- Use a 4 mm allen wrench and remove the 2 screws that hold the solenoid on. Replace the solenoid ensuring that there are 2 o-rings, one on the solenoid inlet and one on the solenoid outlet. The solenoid must be level when tightening screws.

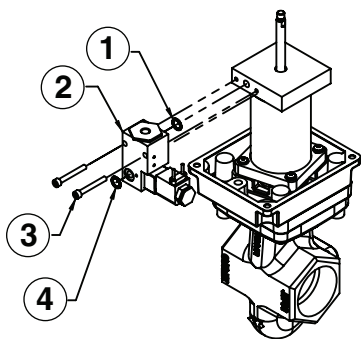

1)	Solenoid o-ring
2)	Solenoid
3)	M5 x 40 socket head cap screw
4)	Solenoid o-ring

- Run the new solenoid wires back up through the liquid tight connector in the housing and align the cylinder shaft with the hole in the housing. Carefully slide housing back into position. Replace the 4 housing screws and leave loose.
- Verify the o-ring is still on the solenoid inlet by looking through the housing collar. Reinstall solenoid inlet fitting tight. Leave the housing collar loose.
- Reinstall solenoid wire #1 and #2 back to the terminal block and tighten down the liquid tight connector nut.
- A locking sealant must be used on the cylinder shaft threads and then reinstall the switch indicator. Make sure to remove any locking sealant that runs down the cylinder shaft. Re-energize pneumatic and electric power and cycle the valve several times to ensure it operates smoothly. Tighten down the 4 housing screws that hold the housing to the base plate using a cross pattern (see torque values on page 32 (Table 1 - Torque Specifications)). Then tighten the housing collar on the solenoid inlet fitting. The o-ring under the housing collar must not be pinched while tightening the housing collar.
- Cycle valve several more times to see if it still operates smoothly. If not, loosen the 4 screws that hold the housing to the base plate and cycle again. Retighten the 4 housing screws. Put the top plate and terminal block covers back on valve (see torque values on page 32 (Table 1 - Torque Specifications)).

## Actuator assembly rotation/replacement

**!** MAXON Series 8000 Valves should be ordered in a configuration compatible with planned piping. If valve orientation is not correct, the actuator assembly can be rotated in 90° increments around the valve body centerline axis using the procedure below. This procedure should also be followed for field replacement of the actuator.

- Shut off all electrical power and close off upstream manual cock.
- Remove terminal block access cover plate [4] and disconnect power lead wires. Caution: Label all wires prior to disconnection when servicing valve. Wiring errors can cause improper and dangerous operation.
- Remove conduit and electrical leads.
- Remove all pneumatic lines.
- Unscrew the actuator/body bolts [5] screwed up from the bottom. These bolts secure the valve actuator [7] to the valve body [6].
- Gently lift the actuator [7] off valve body assembly enough to break the seal between body assembly and the rubber gasket adhering to the bottom of the actuator base plate.
- Carefully rotate/replace actuator assembly to the desired position. Reposition the actuator back down onto the valve body casting.
- Realign holes in valve body casting with the corresponding tapped holes in the bottom of the actuator base plate. Be sure the gasket is still in place between the body and actuator base plate.
- Reinsert the body bolts up from the bottom through the body and carefully engage threads of the actuator assembly. Tighten securely referring to page 32 (Table 1 - Torque Specifications) for appropriate torque specifications.
- Reconnect conduit, electrical leads, and all pneumatic lines, then check that signal switch wands are properly positioned. Failure to correct any such misalignment can result in extensive damage to the internal mechanism of your valve.
- Energize valve and cycle several times from closed to full open position. Also electrically trip the valve in a partially opened position to prove valve operates properly.
- Replace and secure cover plates.
- Verify proper operation after servicing.

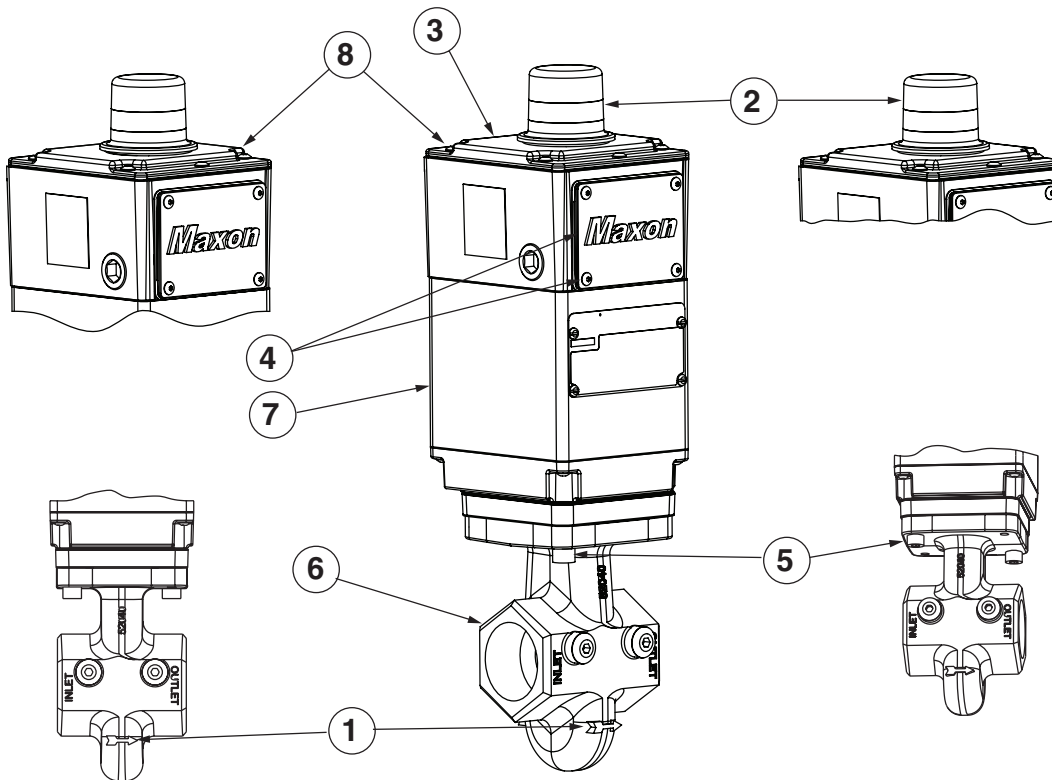

1)	Flow arrow on valve body
2)	Open/shut indicator (see Note 1)
3)	Switch access cover
4)	Terminal block cover and screws
5)	Actuator/body bolts
6)	Valve body
7)	Actuator assembly
8)	Switch access cover screws

Note 1: Open/Shut indication is 360°. If required, the observation window may be cleaned with a damp cloth.



## Field installation of valve position switch

**!** Instructions below are written for normally-closed shut-off valves. For normally-open vent valves, reverse switch nomenclature. (VOS becomes VCS and vice versa.)

**General:** Shut off fuel supply upstream of valve, then de-energize valve electrically.

Remove top cover and terminal block cover to provide access, being careful not to damage gasket. See pages 49 (REPLACEMENT SWITCHES) or 50 (ADD SWITCHES) for instructions on adding or replacing switches.

**!** Substitution of components may affect suitability for Hazardous Locations.

### FIELD REPLACEMENT ITEMS

- Position Switches
- Actuators
- Solenoids

Contact MAXON with valve serial numbers to locate appropriate switch kit assembly.

**Figure 3: Typical switch sub-assemblies**

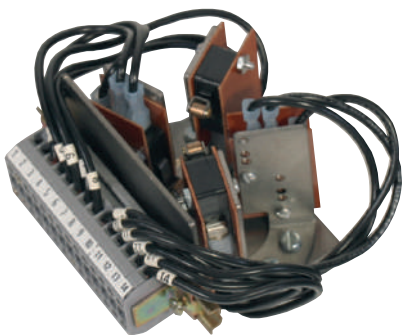

*V7 assembly for General Purpose and Intrinsically Safe valves*

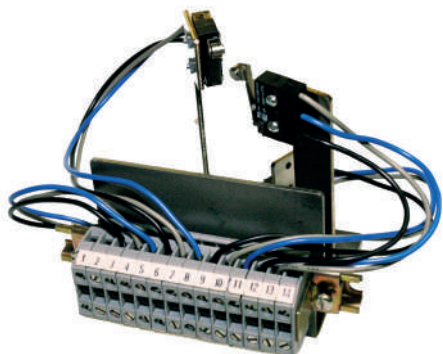

*IP67 Switch assembly for Non-Incendive and optional Intrinsically Safe valves*

## REPLACEMENT SWITCHES

- Carefully remove field wiring from the terminal block (see page 31 (Component identification), item 5). Insure field wires are clearly marked to correct terminal.
- Unwire the solenoid valve lead wires from terminals labeled #1 and #2.
- Remove screws that secure the switch sub-assembly to the actuator housing. The switch sub-assembly should be easily removable from actuator assembly (see Figure 3: Typical Switch Sub-Assemblies).
- Note wand position and mounting hole location. Carefully remove the 2 screws and lift existing switch. Reference Figures 4 through 9 on page 50 (ADD SWITCHES) to ensure correct switch location.
- Install replacement switch in same mounting holes on bracket and verify correct wand position.
- Replace existing wiring one connection at a time, following original route and placement.
- Reassemble switch sub-assembly in actuator housing. Dowel pins are provided to insure proper placement of switch sub-assembly.
- Wire the solenoid valve leads to terminals labeled #1 and #2.
- Cycle valve, checking switch actuation points carefully. VCS switch actuates at top of stem stroke and VOS at bottom for normally-closed shut-off valves; vice-versa for normally-open vent valves.
- Replace covers using torque values on page 32 (Table 1 - Torque Specifications), and then return valve to service.

### ADD SWITCHES

- Carefully remove field wiring from the terminal block (see page 31 (Component identification), item 5). Insure field wires are clearly marked to correct terminal.
- Unwire the solenoid valve lead wires from terminals labeled #1 and #2.
- Remove screws that secure the switch sub-assembly to the actuator housing. The switch sub-assembly should be easily removable from actuator assembly (see page 49 (Figure 3: Typical switch sub-assemblies)).
- Reference Figures 4 through 9 (below) to ensure correct switch location. Valve size is depicted in the model number by the first 4 dig- its. For example, a 3" CP valve should have Model No. 300C.
- Install switch and insulators, when provided, to correct hole. Insure proper alignment. VCS switch should have activation wand pointed upward and VOS activation wand should be pointed downward.
- Wire new switches to terminals provided.
- Reassemble switch sub-assembly in actuator housing. Dowel pins are provided to insure proper placement of switch sub-assembly.
- Wire the solenoid valve leads to terminals labeled #1 and #2.
- Cycle valve, checking switch actuation points carefully. VCS switch actuates at top of stem stroke and VOS at bottom for normally- closed shut-off valves; vice-versa for normally-open vent valves.
- Replace covers using torque values on page 32 (Table 1 - Torque Specifications), and then return valve to service.

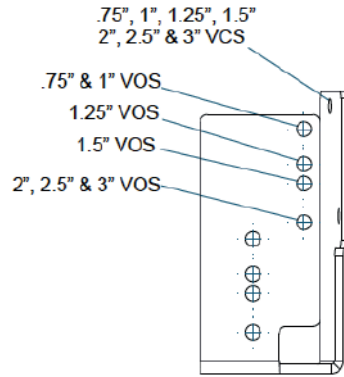

Figure 6:  
General Purpose  
Switch Bracket

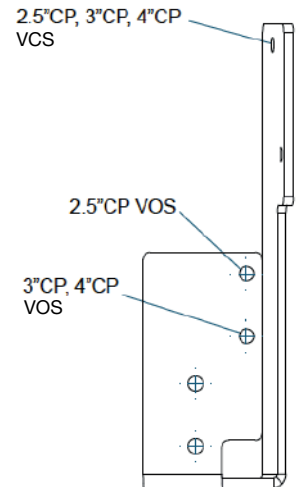

Figure 7:  
General Purpose  
Switch Assembly



Figure 8:  
6" & 8" Valve IP67  
Switch Bracket

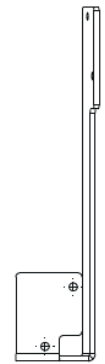

Figure 9:  
6" & 8" Valve General  
Purpose Switch Bracket

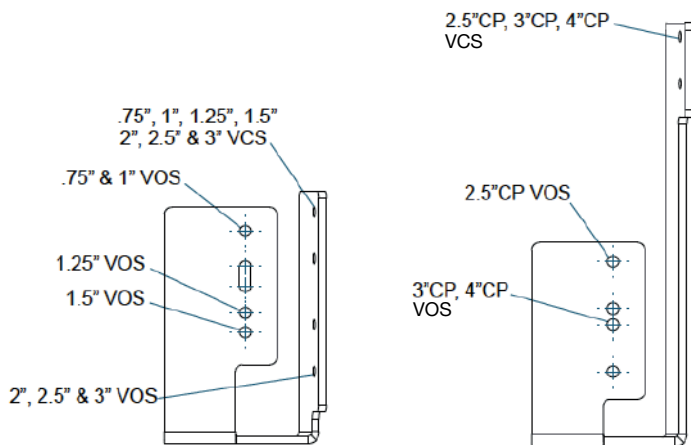

Figure 4:  
IP67 Switch Bracket

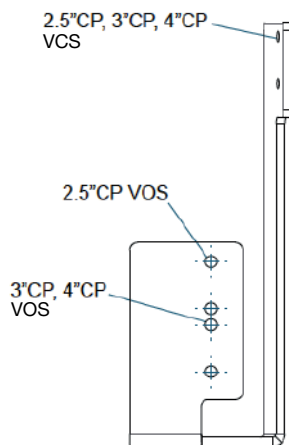

Figure 5:  
IP67 Switch Bracket

## IEC 61508 INSTRUCTION REQUIREMENTS

### PRODUCT DESCRIPTION

A Failure Mode, Effects, and Diagnostics Analysis (FMEDA) report is available from MAXON. Detailed failure rate data is available in the FMEDA reports. Data for Series 8000 Valves with internal solenoids only can be found in Exida Report MAX 08/09-07 R002. Data for Series 8000 Valves with internal solenoid and redundant external solenoid can be found in Exida Report MAX 1208063 R002.

### PRIMARY SAFETY FUNCTION

- a. Series 8\*1\*, Normally Closed will pass flow when energized and shut off flow within the stated leakage specification when de-energized.
- b. Series 8\*2\*, Normally Open will pass flow when de-energized and shut off flow within the stated leakage specification when energized.
- c. The valves are designed for low demand applications.
- d. The valve must be within specified operating conditions, as found in the instruction manual.

### PROOF TEST

The objective of proof testing is to detect failures within the Series 8000 Valve that prevent the valve from performing its safety function.

The frequency of proof testing, or the proof test interval, is to be determined in reliability calculations for the safety instrumented functions for which the Series 8000 Valve is applied. The proof tests must be performed more frequently or as frequently as specified in the calculation in order to maintain the required safety integrity of the safety instrumented function.

Maintenance instructions include a Valve Leak Test. These instructions must be followed during the proof test. This Valve Leak Test will detect approximately 99% of possible DU (Dangerous Undetected) failures resulting in a Proof Test Coverage of 99% for the valve. For specific recommendations on leak test procedures, see MAXON [Valve Technical Document 10-35.2-1](#).

The person(s) performing the proof test of the Series 8000 Valve should be trained in SIS (Safety Instrumented Systems) operations, including bypass procedures, valve maintenance and Company Management of Change procedures.

If implementing partial stroke testing of Series 8000 Valves, see MAXON PSCheck documentation (Form

Number 32M-05004) for diagnostic coverage information related to Series 8000 Valves.

### RELIABILITY DATA AND LIFETIME LIMIT

A detailed Failure Mode, Effects, and Diagnostics Analysis (FMEDA) report is available from MAXON. This report details all failure rates and failure modes, common cause factors for applications with redundant devices and the expected lifetime of the Series 8000 Valve.

- a. The Series 8000 Valve is intended for low demand mode applications up to SIL 3 for use in a simplex (1oo1) configuration, depending on the PFDAVG calculation of the entire Safety Instrumented Function.
- b. The development process of the Series 8000 Valve is certified up to SIL 3, allowing redundant use of the valve up to this Safety Integrity Level, depending on the PFDAVG calculation of the entire Safety Instrumented Function.
- c. When using the Series 8000 Valve in a redundant configuration, a common cause factor should be included in reliability calculations. For details, see the FMEDA report.
- d. The reliability data listed in the FMEDA report is only valid for the useful lifetime of the Series 8000 Valve. The failure rates of the Series 8000 Valve may increase sometime after this period. Reliability calculations based on the data listed in the FMEDA report for mission times beyond the lifetime may yield results that are too optimistic, i.e. the calculated Safety Integrity Level will not be achieved.

### PRODUCT SAFETY OFFICER

Any failures that are detected and that compromise functional safety should be reported to the Product Safety Officer within MAXON. Please contact MAXON Customer Service.

## **FITTING CERTIFICATE**

We:

MAXON Corporation

Address:

201 E. 18th Street

Muncie, IN 47302

USA

Declare that all fittings produced at the above address  
within the following product group:

MAXON Series 8000 Air Actuated Valves

Conform to all applicable provisions of the European Gas  
Appliance Regulation.

Certificate number: CE 681603 applies

EC Surveillance: BSI (Notified Body Number 2797)

This certificate issued by: MAXON Corporation

Name: Lora Davis

Title/Position: Product Engineering Manager

Date of issue: September 26, 2019

### **For More Information**

The Honeywell Thermal Solutions family of products includes Honeywell Combustion Safety, Eclipse, Exothermics, Hauck, Kromschröder and Maxon. To learn more about our products, visit [ThermalSolutions.honeywell.com](http://ThermalSolutions.honeywell.com) or contact your Honeywell Sales Engineer.

### **Honeywell MAXON branded products**

201 E. 18th Street

Muncie, IN 47302

USA

[www.maxoncorp.com](http://www.maxoncorp.com)

### **Honeywell Process Solutions**

Honeywell Thermal Solutions (HTS)

1250 West Sam Houston Parkway

South Houston, TX 77042

[ThermalSolutions.honeywell.com](http://ThermalSolutions.honeywell.com)

® U.S. Registered Trademark.

© 2021 Honeywell International Inc.

32M-05003-03 Rev. 08-21

EAS 50111985-001

Printed in U.S.A.

The Honeywell logo is displayed in a bold, red, sans-serif font.