

## Safety shut-off valves JSAV

### TECHNICAL INFORMATION

- For positive pressure with over-pressure shut-off
- DN 25, DN 40: with under-pressure shut-off
- Large adjusting range for trip pressure
- DN 25../2, DN 40../2: no breather line required
- EU certified



---

# Contents

<b>Contents</b> .....	<b>2</b>	<b>10 Converting units</b> .....	<b>19</b>
<b>1 Application</b> .....	<b>3</b>	<b>11 Maintenance cycles</b> .....	<b>20</b>
1.1 Application examples .....	4	<b>For more information</b> .....	<b>21</b>
<b>2 Certification</b> .....	<b>5</b>		
2.1 Certificate download .....	5		
2.2 EU certified .....	5		
2.3 Eurasian Customs Union .....	5		
2.4 UKCA certified .....	5		
<b>3 Function</b> .....	<b>6</b>		
3.1 JSAV 25–40 .....	6		
3.2 JSAV 50–100 .....	7		
<b>4 Flow rate</b> .....	<b>8</b>		
4.1 Calculating the nominal size .....	9		
<b>5 Selection</b> .....	<b>10</b>		
5.1 ProFi .....	10		
5.2 JSAV .....	10		
5.3 JSAV..T .....	11		
<b>6 Project planning information</b> .....	<b>12</b>		
6.1 Installation .....	12		
<b>7 Accessories</b> .....	<b>13</b>		
7.1 Reset lever .....	13		
7.2 Position switch for remote indication .....	13		
<b>8 Technical data</b> .....	<b>14</b>		
8.1 Ambient conditions .....	14		
8.2 Mechanical data for JSAV 25–40 .....	15		
8.2.1 Spring table JSAV 25–40../1, JSAV 25–40../2 .....	15		
8.3 Mechanical data for JSAV 25–40 .....	16		
8.3.1 Spring table JSAV 50–100../1 .....	16		
<b>9 Dimensions</b> .....	<b>17</b>		
9.1 JSAV 25 – 40 .....	17		
9.2 JSAV 50 – 100 .....	18		

## 1 Application



JSAV 25



JSAV 40



JSAV 50 – 100

Controls which are connected downstream of a gas pressure regulator are secured against excess gas pressure. If the required operating conditions are not met, the gas supply is shut off.

A safety shut-off valve is required in accordance with EN 746-2 for all gas pressure control systems in which the controls downstream of the gas pressure regulator are not resistant to the supply pressure.

## 1.1 Application examples

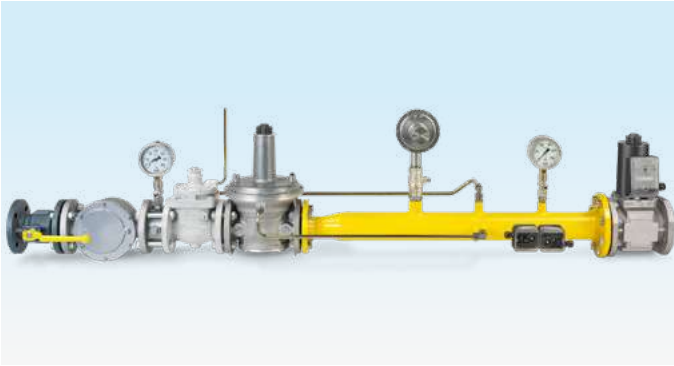

The JSAV protects all controls downstream of the gas pressure regulator in the gas inlet section.

# 2 Certification

## 2.1 Certificate download

Certificates – see [www.docuthek.com](http://www.docuthek.com)

## 2.2 EU certified



- (EU) 2016/426 (GAR) – Gas Appliances Regulation
- Pressure Equipment Directive (2014/68/EU), Class A  
JSAV 25 – 40 with over-pressure/under-pressure shut-off
- Pressure Equipment Directive (2014/68/EU), Class B  
JSAV 25 – 40 with over-pressure shut-off  
JSAV 50 – 100 with over-pressure shut-off
- DIN EN 14382:2009

## 2.3 Eurasian Customs Union



The products JSAV meet the technical specifications of the Eurasian Customs Union.

## 2.4 UKCA certified



Gas Appliances (Product Safety and Metrology etc.  
(Amendment etc.) (EU Exit) Regulations 2019)

BS EN 14382:2019

## 3 Function

### 3.1 JSAV 25–40

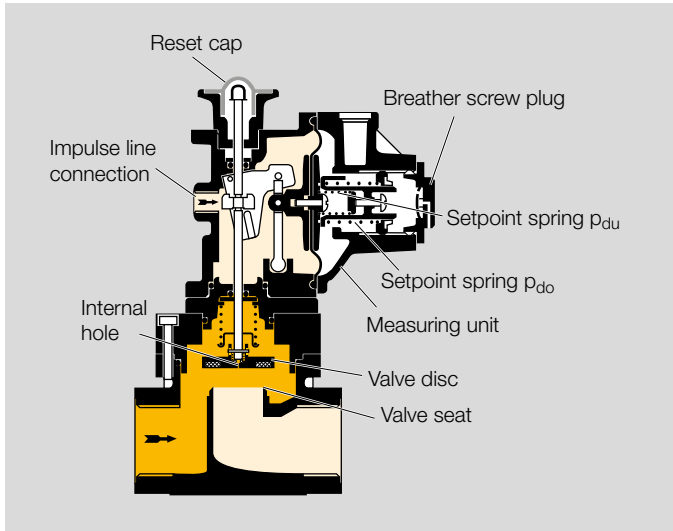

The upper trip pressure is set using the outer setpoint spring in the measuring unit. The lower trip pressure is set using the inner spring in the measuring unit. The JSAV measures the pressure downstream of the gas pressure regulator via an external impulse line.

The JSAV closes once the set trip pressure has been reached. The valve plate is pressed onto the valve seat and thus shuts off the gas supply safely.

The position of the valve plate can be seen through the transparent reset cap.

The JSAV is manually reset. To do so, the pressure in the impulse line must be between the upper and lower trip pressure.

First, unscrew and remove the breather screw plug. Then loosen the reset cap. By pulling the reset cap slightly, the pressure is equalized via an internal hole in the valve plate. Once pressure equalization is complete, the reset cap can be lifted easily and the valve plate is engaged in the open position.

In the case of a JSAV../2 (Class A device according to the Pressure Equipment Directive (2014/68/EU) with over-pressure and under-pressure shut-off), a relief line is not required on the measuring unit, as a maximum of 30 l/h can escape via the hole in the breather screw plug.

## 3.2 JSAV 50–100

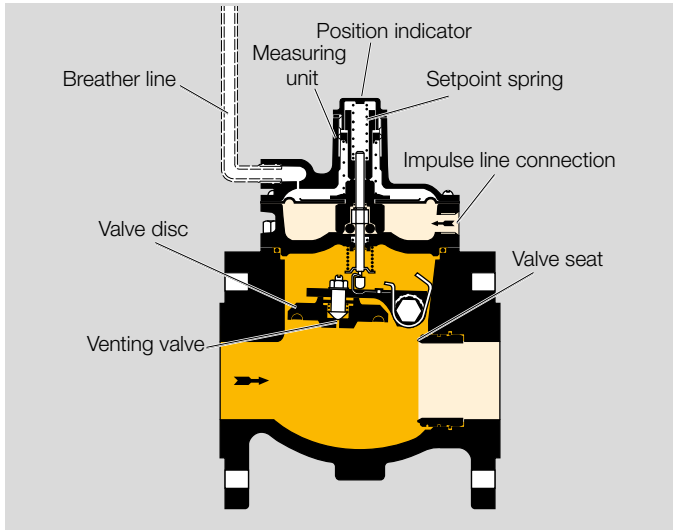

sure and under-pressure shut-off), a breather line must be connected to the measuring unit to ensure that the closing function is activated as soon as the trip pressure is exceeded. A visual position indicator to show the current position of the device can be implemented by means of an electric switch as an option, see page 13 (7.2 Position switch for remote indication).

The free-flow valve design allows for a very large flow rate despite a compact design.

The trip pressure is set using the setpoint spring in the measuring unit. The JSAV measures the pressure downstream of the gas pressure regulator via an external impulse line.

The JSAV closes once the set trip pressure has been reached. The valve plate is pressed onto the valve seat and thus shuts off the gas supply safely.

The device can simply be manually reset. The pressure in the impulse line must be distinctly below the trip pressure.

To begin with, a pressure equalization is carried out via the integrated venting valve in the valve plate using the supplied reset lever. Afterwards, the valve plate is fully opened and finally engages.

In the case of a JSAV../1 (Class B device according to the Pressure Equipment Directive (2014/68/EU) with over-pres-

# 4 Flow rate

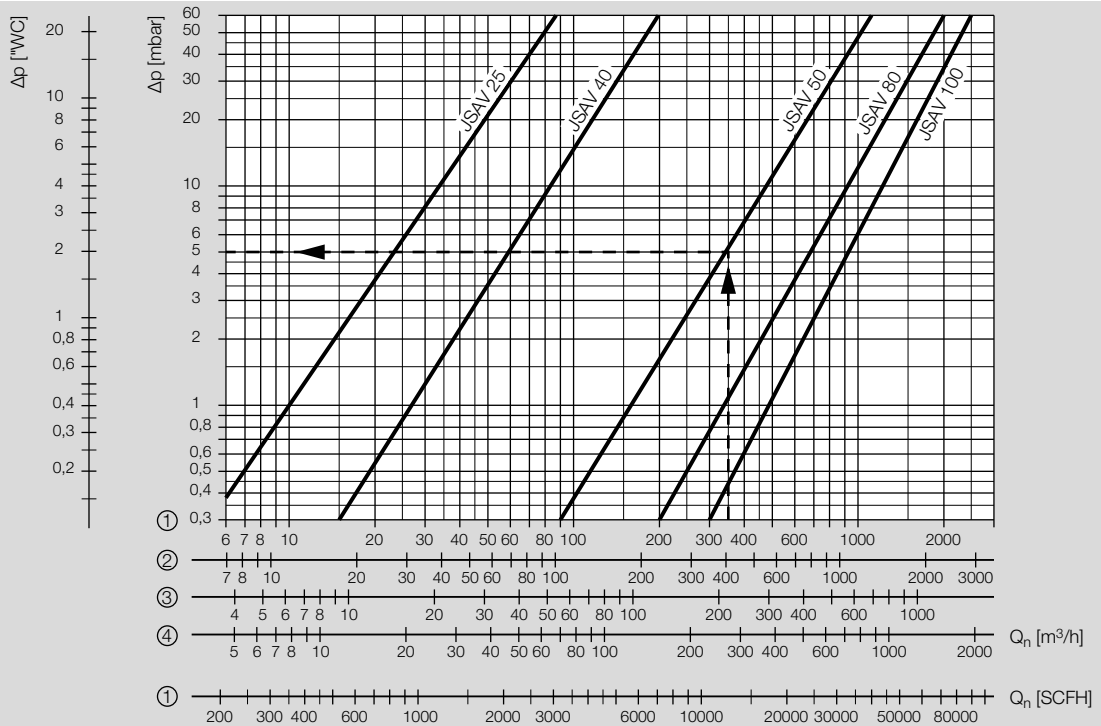

- 1 = natural gas ( $\rho = 0.80 \text{ kg/m}^3$ )
- 2 = town gas ( $\rho = 0.58 \text{ kg/m}^3$ )
- 3 = propane ( $\rho = 2.01 \text{ kg/m}^3$ )
- 4 = air ( $\rho = 1.29 \text{ kg/m}^3$ )

### Reading instructions

When determining the pressure loss, operating cubic metres must be entered. Then the pressure loss  $\Delta p$  read must be multiplied by the absolute pressure in bar (positive pressure + 1) to account for the change in the medium's density.

### Example

inlet pressure  $p_u$  (positive pressure) = 4 bar,  
 gas type: natural gas,  
 operating flow rate  $Q_b = 350 \text{ m}^3/\text{h}$ ,  
 selected in the diagram: JSAV 50,  
 $\Delta p$  from diagram = 5 mbar,  
 $\Delta p = 5 \text{ mbar} \times (1 + 4) = 25 \text{ mbar}$  on JSAV 50



### 4.1 Calculating the nominal size

A web app for calculating the nominal size is available at [www.adlatus.org](http://www.adlatus.org).

## 5 Selection

### 5.1 ProFi

A web app selecting the correct product is available at [www.adlatus.org](http://www.adlatus.org).

### 5.2 JSAV

Description	Code	JSAV 25	JSAV 40	JSAV 50–100	Condition
Safety shut-off valve	<b>JSAV</b>	•	•	•	
Nominal size	<b>25–100</b>	25	40	50, 80, 100	
<b>Pipe connection</b>					
Rp internal thread	<b>R</b>	•	•		
Flange to ISO 7005	<b>F</b>		•	•	
<b>Inlet pressure</b>					
$p_U$ max. 4 bar	<b>40</b>	•	•		
$p_U$ max. 5 bar	<b>50</b>			•	
<b>Monitoring</b>					
Over-pressure shut-off $p_{do}$	<b>/1</b>	•	•	•	
Over-pressure and under-pressure shut-off $p_{do/du}$	<b>/2</b>	•	•		
<b>Pressure test point</b>					
No pressure test point	<b>-0</b>	•		•	
Screw plug at the inlet and outlet	<b>-3</b>		•		
<b>Trip pressure</b>					
Special adjusting range	<b>Z</b>	•	•	•	When ordering a JSAV..Z, be sure to specify the desired trip pressure and adjusting range.

### Order example

JSAV 40F40/2-3

## 5.3 JSAV..T

Description	Code	JSAV 25T	JSAV 40T	JSAV 50T-100T	Condition
Safety shut-off valve	<b>JSAV</b>	•	•	•	
Nominal size	<b>25-100</b>	25	40	50, 80, 100	
<b>Pipe connection</b>					
NPT internal thread	<b>N</b>	•	•		
ANSI flange	<b>A</b>			•	
<b>Inlet pressure</b>					
p <sub>U</sub> max. 4 bar	<b>40</b>	•	•		
p <sub>U</sub> max. 5 bar	<b>50</b>			•	
<b>Monitoring</b>					
Over-pressure shut-off p <sub>do</sub>	<b>/1</b>	•	•	•	
<b>Pressure test point</b>					
No pressure test point	<b>-0</b>	•		•	
Screw plug at the inlet and outlet	<b>-3</b>	•			
<b>Trip pressure</b>					
Special adjusting range	<b>Z</b>	•	•	•	When ordering a JSAV..Z, be sure to specify the desired trip pressure and adjusting range.

## Order example

JSAV 25TN40/1-3

## 6 Project planning information

### 6.1 Installation

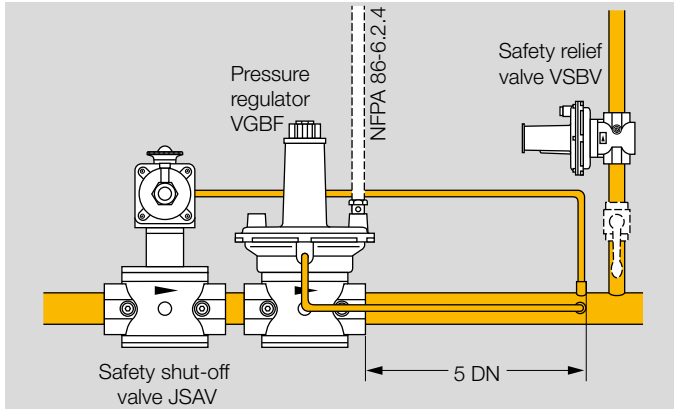

If the controls downstream of the gas pressure regulator are not resistant to the supply pressure, EN 746-2 prescribes a safety shut-off valve upstream and a safety relief valve downstream of the gas pressure regulator – regardless of how high the inlet pressure is.

Ensure that there is sufficient tube length for the impulse line.

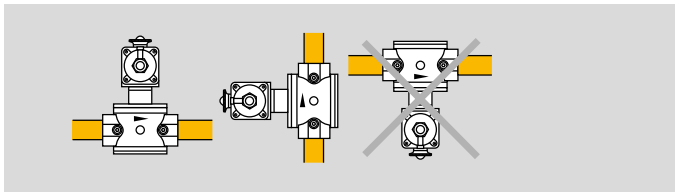

Installation in the vertical or horizontal position, never upside down.

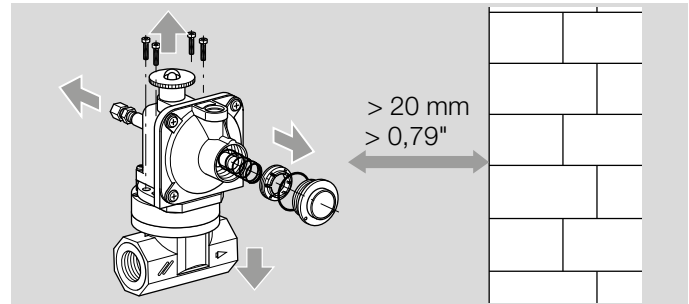

Install the unit free of mechanical stress and so that it is not in contact with masonry (min. clearance 20 mm (0.79")).

Ensure that there is sufficient space for installation, adjustment and maintenance work.

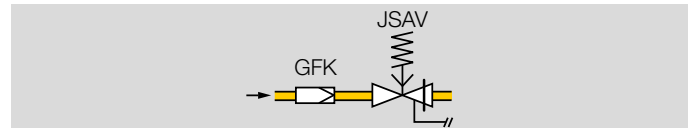

Sealing material and thread cuttings must not be allowed to get into the valve housing. Install a filter upstream of every system.

Do not store or install the unit in the open air.

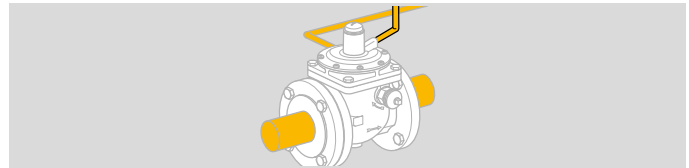

A breather line must be connected to the measuring unit to maintain the function of the JSAV.

## 7 Accessories

### 7.1 Reset lever

Reset lever to reset JSAV 50 – 100:

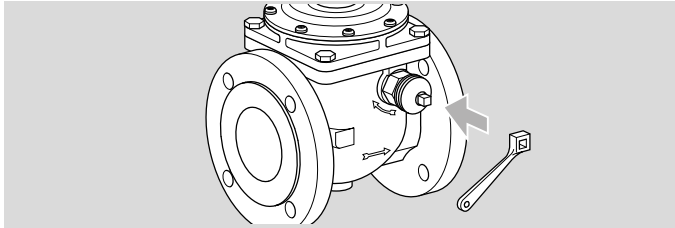

Order No.: 03151140.

### 7.2 Position switch for remote indication

The position switch can be used for electronic position checks.



Order No.: 03151185.

## 8 Technical data

### 8.1 Ambient conditions

Icing, condensation and dew in and on the unit are not permitted.

Avoid direct sunlight or radiation from red-hot surfaces on the unit. Note the maximum medium and ambient temperatures!

Note the maximum medium and ambient temperatures!

Avoid corrosive influences, e.g. salty ambient air or SO<sub>2</sub>.

The unit may only be stored/installed in enclosed rooms/buildings.

Ambient temperature: -20 to +60°C (-4 to 140°F).

Long-term use in the upper ambient temperature range accelerates the ageing of the elastomer materials and reduces the service life (please contact manufacturer).

Storage temperature: -20 to +40°C (-4 to 104°F).

Transport temperature: -20 to +60°C (-4 to 140°F).

The gas must be clean and dry in all temperature conditions and must not contain condensate.

This unit is not suitable for cleaning with a high-pressure cleaner and/or cleaning products.

## 8.2 Mechanical data for JSAV 25–40

Gas type: natural gas, town gas, LPG (gaseous), biogas (max. 0.02 %-by-vol. H<sub>2</sub>S) = Group 1 fluids pursuant to Directive 2014/68/EU or air.

Medium temperature = ambient temperature.

Max. inlet pressure  $p_{i_u}$ : 4 bar (58 psig).

Max. test pressure for testing the JSAV:  
inlet and outlet temporarily < 15 min: 6 bar (87 psig),  
impulse line temporarily < 15 min:  
750 mbar (10.8 psig).

Trip pressures  $p_{d_o}/p_{d_u}$  preset at the factory:  
upper trip pressure  $p_{d_o}$ : 120 mbar (48.2 "WC),  
lower trip pressure  $p_{d_u}$ : 10 mbar (3.9 "WC).

Trip pressure ranges, see page 15 (8.2.1 Spring table JSAV 25–40../1, JSAV 25–40../2).

Accuracy group: AG 10.

Connection for housing:  
JSAV..R: Rp internal thread to ISO 7-1,  
JSAV..N: NPT internal thread,  
JSAV..F: PN 16 flange to ISO 7005,  
JSAV..A: ANSI flange.

Connection for impulse line: DN 8 (1/8 NPT) (Ermeto coupling installed).

Housing: AISi.

Diaphragm: NBR.

Valve seat: aluminium.

Valve stem: stainless steel.

Valve plate: steel with vulcanized NBR seal.

### 8.2.1 Spring table JSAV 25–40../1, JSAV 25–40../2

Various trip pressure ranges can be achieved by using different springs.

#### Upper trip pressure $p_{d_o}$

[mbar]	["WC]	Marking	Order No.
18–60*	7–23.4*	black	03089068*
50–80	19.5–31.2	orange	03089069
60–110	23.4–42.9	red	03089070
100–210**	39–81.9**	dark green	03089071**
200–350	78–136.5	yellow	03089072
280–500	109.2–195	white	03089073

#### Lower trip pressure $p_{d_u}$

[mbar]	["WC]	Marking	Order No.
8–16**	3.12–6.24**	light blue	03089082**
16–60	6.24–23.4	brown	03089083
60–150	23.4–58.5	violet	03089084

\* Approved for pressures from 40 mbar and higher

\*\* Standard spring

### 8.3 Mechanical data for JSAV 25–40

Gas type: natural gas, town gas, LPG (gaseous), biogas (max. 0.02 %-by-vol. H<sub>2</sub>S) = Group 1 fluids pursuant to Directive 2014/68/EU or air.

Medium temperature = ambient temperature.

Max. inlet pressure  $p_U$ : 5 bar (72.5 psig).

Max. test pressure for testing the JSAV: inlet and outlet temporarily < 15 min: 7.5 bar (109 psig), impulse line temporarily < 15 min: 750 mbar (10.8 psig).

Trip pressure ranges, see page 16 (8.3.1 Spring table JSAV 50–100../1).

Accuracy group: AG 10.

Connection for housing:  
JSAV..F: PN 16 flange to ISO 7005,  
JSAV..A: ANSI flange.

Connection for impulse and breather lines: Rp 1/4 (1/4 NPT).

Housing: GGG 40.

Diaphragm: NBR.

Valve seat: aluminium.

Valve stem: stainless steel.

Valve plate: aluminium with vulcanized NBR seal.

### 8.3.1 Spring table JSAV 50–100../1

Various trip pressure ranges can be achieved by using different springs.

#### Upper trip pressure $p_{do}$

[mbar]	["WC]	Marking	Order No.
35–70	0.51–1.02	light blue	03089063
60–170*	0.9–2.5	reddish brown	03089064*
120–220	1.74–3.2	crimson	03089065
190–400	2.8–5.8	orange/yellow	03089066
300–550	4.35–8	orange/green	03089067

\* Standard spring



## 9 Dimensions

### 9.1 JSAV 25 – 40

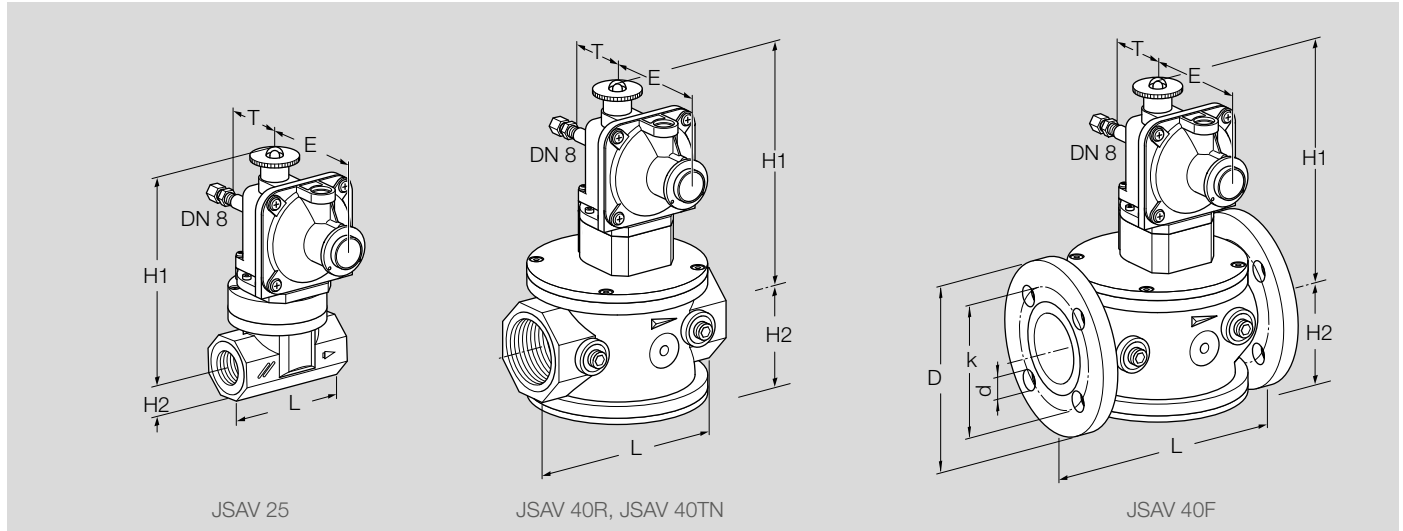

#### With Rp internal thread or with ISO flange

Type	Connection	Dimensions [mm]					Flange [mm]		Drillings		Weight [kg]
		H1	H2	L	T	E	D	k	d [mm]	Number	
JSAV 25R40	Rp 1	159	23	91	43	87	–	–	–	–	1
JSAV 40R40	Rp 1½	206	51	150	43	87	–	–	–	–	2.3
JSAV 40F40	DN 40	187	75	200	43	87	150	110	18	4	3.1

#### With NPT internal thread

Type	Connection	Dimensions [inch]					Weight [lbs]
		H1	H2	L	T	E	
JSAV 25TN40	1 NPT	6.26	0.91	3.58	1.70	3.42	2.2
JSAV 40TN40	1½ NPT	8.11	2.00	5.91	1.70	3.42	4.85

9.2 JSAV 50 – 100

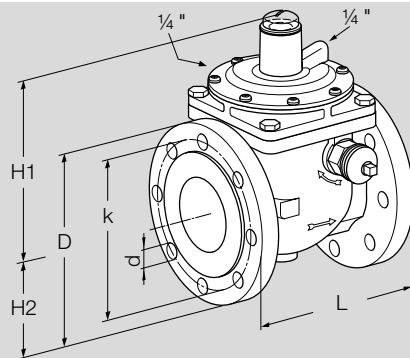

With ISO flange

Type	Connection	Dimensions [mm]			Flange [mm]		Drillings		Weight
		H1	H2	L	D	k	d [mm]	Number	[kg]
JSAV 50F50	DN 50	187	83	180	165	125	18	4	13
JSAV 80F50	DN 80	200	100	220	200	160	18	8	17
JSAV 100F50	DN 100	226	110	270	220	180	18	8	24

With ANSI flange

Type	Connection	Dimensions [inch]			Flange [inch]		Drillings		Weight
		H1	H2	L	D	k	d [inch]	Number	[lbs]
JSAV 50TA50	DN 50	7.36	3.27	7.09	6.50	4.75	0.71	4	28.6
JSAV 80TA50	DN 80	7.87	3.94	8.66	7.87	6.00	0.71	4	37.4
JSAV 100TA50	DN 100	8.90	4.33	10.63	8.66	7.50	0.71	8	52.8

## **10 Converting units**

See [www.adlatus.org](http://www.adlatus.org)

## **11 Maintenance cycles**

At least once a year, at least twice a year in the case of biologically produced methane.

## For more information

The Honeywell Thermal Solutions family of products includes Honeywell Combustion Safety, Eclipse, Exothermics, Hauck, Kromschroder and Maxon. To learn more about our products, visit [ThermalSolutions.honeywell.com](https://ThermalSolutions.honeywell.com) or contact your Honeywell Sales Engineer.

Elster GmbH  
Strothweg 1, D-49504 Lotte  
T +49 541 1214-0  
[hts.lotte@honeywell.com](mailto:hts.lotte@honeywell.com)  
[www.kromschroeder.com](http://www.kromschroeder.com)

© 2022 Elster GmbH

We reserve the right to make technical modifications in the interests of progress.

