

## Gas pressure regulator GDJ

### TECHNICAL INFORMATION

- Universal pressure regulator for gaseous media
- Design with inlet pressure compensation diaphragm ensures high control accuracy
- Internal impulse
- Feedforwarding the furnace chamber pressure is possible
- No breather line required
- EU certified

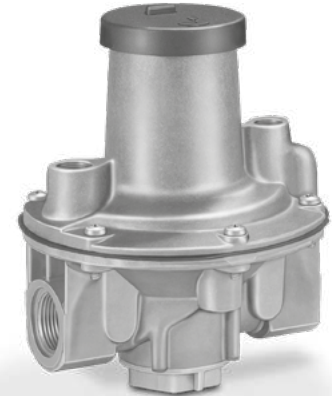

---

# Contents

<b>Contents</b> .....	<b>2</b>
<b>1 Application</b> .....	<b>3</b>
1.1 Application examples .....	3
<b>2 Certification</b> .....	<b>5</b>
<b>3 Function</b> .....	<b>6</b>
<b>4 Flow rate</b> .....	<b>7</b>
4.1 Calculating the nominal size .....	8
<b>5 Selection</b> .....	<b>9</b>
5.1 Selection table .....	9
5.2 ProFi .....	9
5.3 Type code .....	9
5.3.1 GDJ .....	9
5.3.2 GDJ.T .....	9
<b>6 Project planning information</b> .....	<b>10</b>
6.1 Installation .....	10
6.2 Installation to EN 746-2 .....	10
6.3 Vent restrictor to ANSI/CSA .....	10
6.4 Feedforwarding the furnace chamber pressure .....	11
<b>7 Technical data</b> .....	<b>12</b>
7.1 Dimensions .....	13
7.2 GDJ spring table .....	14
7.3 Converting units .....	15
<b>8 Maintenance cycles</b> .....	<b>16</b>
<b>Fore more information</b> .....	<b>17</b>

## 1 Application

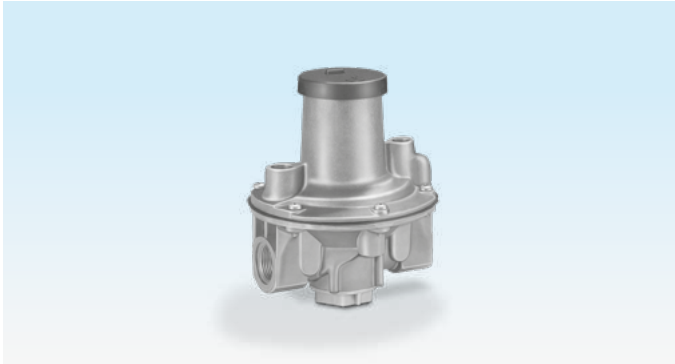

*GDJ 25*

The spring-loaded gas pressure regulator GDJ with inlet pressure compensation diaphragm and zero shut-off serves to maintain the set outlet pressure constant despite changing gas flow rates and inlet pressures in gas pipelines. Thanks to an additional safety diaphragm, no breather line is required.

For controlling the pressure of the gas and air supply to gas burners and gas appliances in industry and the heating sector.

### 1.1 Application examples



*Bogie hearth furnace*



*Roller hearth furnace*



*Intermittent shuttle kiln*

## 2 Certification

Certificates – see [www.docuthek.com](http://www.docuthek.com)

### EU certified



- (EU) 2016/426 (GAR) – Gas Appliances Regulation
- EN 88-1:2011

### Eurasian Customs Union



The product GDJ meets the technical specifications of the Eurasian Customs Union.

### 3 Function

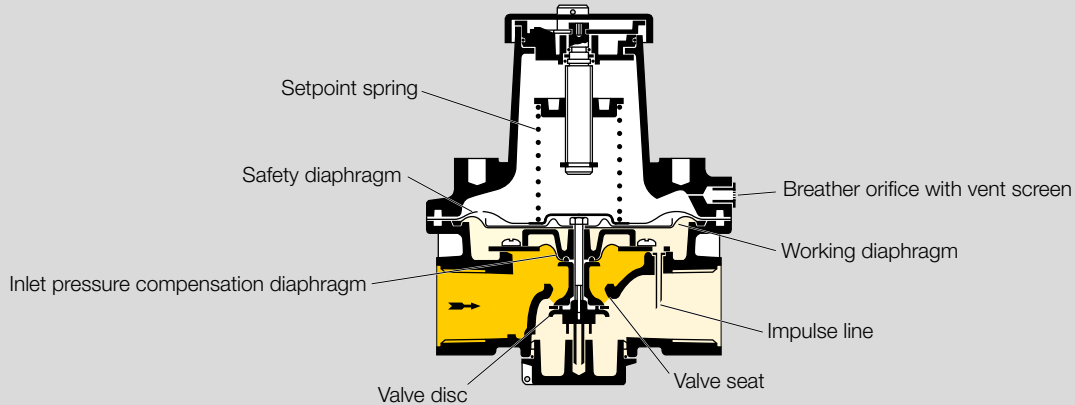

Gas pressure regulator GDJ is open when no pressure is applied.

The gas supply is opened slowly and the gas flows via the valve seat to the pressure regulator outlet. The outlet pressure is applied to the working diaphragm from below via the impulse line. As soon as the outlet pressure corresponds to the set spring force, the working diaphragm lifts and the valve disc connected to it reduces the flow rate.

If the outlet pressure drops, e.g. due to switching on a consumer, the valve disc is opened further and the outlet pressure increases again.

If the outlet pressure increases, e.g. due to reduced consumption, the valve disc is closed further and the outlet pressure decreases again. Thus, the outlet pressure is maintained constant despite changing gas flow rates.

If consumption is stopped, the valve disc closes completely (zero shut-off).

Fluctuations in the inlet pressure are compensated by the inlet pressure compensation diaphragm.

For measuring the inlet pressure, the optional pressure test nipple at the inlet can be used.

## 4 Flow rate

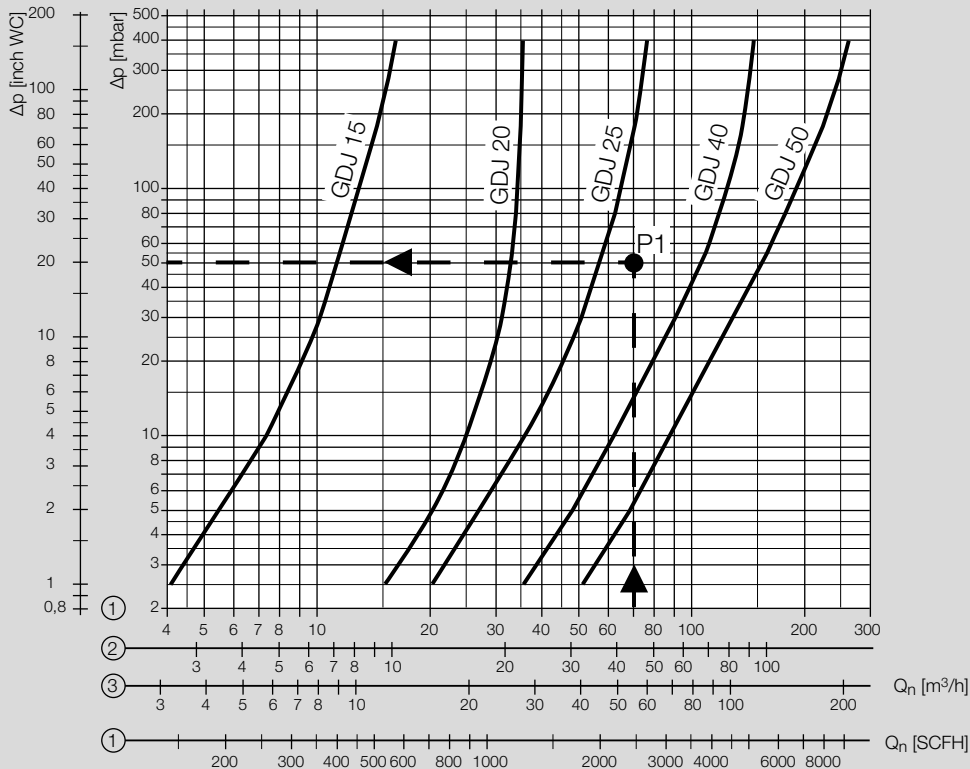

- 1 = natural gas ( $\rho = 0.80 \text{ kg/m}^3$ )
- 2 = town gas ( $\rho = 0.58 \text{ kg/m}^3$ )
- 3 = propane ( $\rho = 2.01 \text{ kg/m}^3$ )
- 4 = air ( $\rho = 1.29 \text{ kg/m}^3$ )

### Example

Gas type: natural gas,  
flow rate  $Q = 70 \text{ m}^3/\text{h}$  (2613 SCFH),

inlet pressure  $p_u = 70 \text{ mbar}$  (28.1 "WC),  
outlet pressure  $p_d = 20 \text{ mbar}$  (8.0 "WC),  
pressure loss  $\Delta p = p_u - p_d = 50 \text{ mbar}$  (20.1 "WC).

The result is intersection P1. The next largest nominal size is selected: GDJ 40.

At a pressure loss of  $\Delta p = 50 \text{ mbar}$  (20.1 "WC), the max. flow rate is  $Q_{\text{max.}}: 105 \text{ m}^3/\text{h}$  (3920 SCFH).

## Flow rate

---

The min. flow rate  $Q_{\min.}$  is derived from  $Q_{\min.} = Q_{\max.} \times 10\% = 10,5 \text{ m}^3/\text{h}$  (392 SCFH).

### 4.1 Calculating the nominal size

A web app selecting the correct product is available at [www.adlatus.org](http://www.adlatus.org).



## 5 Selection

### 5.1 Selection table

Option	GDJ	GDJ..T
DN	15, 20, 25, 40, 50	15, 20, 25, 40, 50
Pipe connection	R	N
Inlet pressure	04	04
Pressure measuring point	-0, -4	-0
For air only (without approval)	L	L

#### Order example

GDJ 40R04-4

### 5.2 ProFi

A web app selecting the correct product is available at [www.adlatus.org](http://www.adlatus.org).

### 5.3 Type code

#### 5.3.1 GDJ

<b>GDJ</b>	Pressure regulator for gas
<b>15-50</b>	Nominal size
<b>R</b>	Rp internal thread
<b>04</b>	$p_u$ max. 400 mbar
<b>-0</b>	No pressure test point
<b>-4</b>	Pressure test point at the inlet
<b>L</b>	Only for air (without approval)
<b>Z</b>	Special outlet pressure range

\* Not for T-product.

#### 5.3.2 GDJ..T

<b>GDJ</b>	Pressure regulator for gas
<b>15-50</b>	Nominal size
<b>T</b>	T-product
<b>N</b>	NPT internal thread
<b>04</b>	$p_u$ max. 5 psig (350 mbar)
<b>-0</b>	No pressure test point
<b>L</b>	Only for air
<b>Z</b>	Special outlet pressure range

## 6 Project planning information

### 6.1 Installation

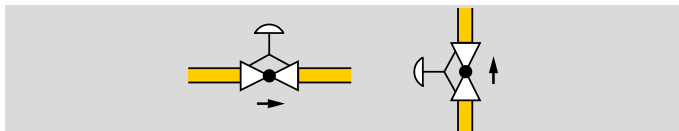

Installation position: spring dome pointing vertically upwards or to the side, not upside down.

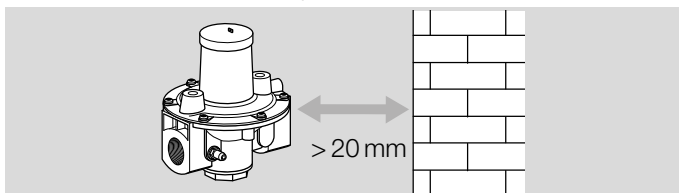

The gas pressure regulator GDJ must not be in contact with masonry. Minimum clearance 20 mm (0.8 inch). Ensure that there is sufficient space for changing the spring.

Do not store or install the unit in the open air.

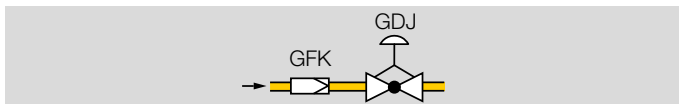

Sealing material and dirt, e.g. thread cuttings, must not be allowed to get into the regulator housing.

Install a filter (GFK) upstream of every system.

### 6.2 Installation to EN 746-2

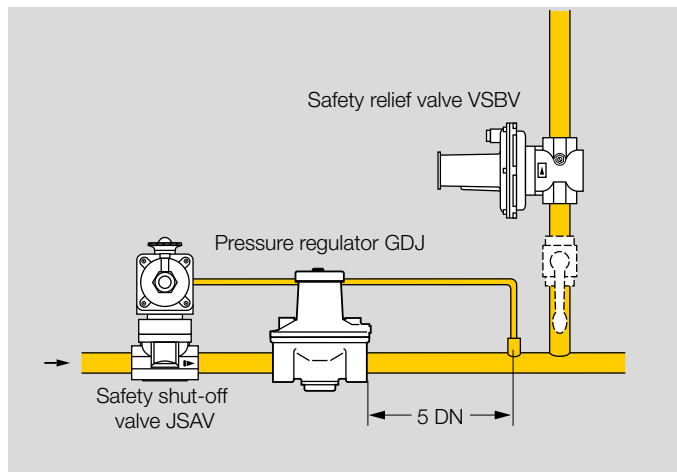

In accordance with EN 746-2, a safety shut-off valve upstream of the gas pressure regulator and a safety relief valve are required for gas pressure control systems.

These valves are not required if the highest possible operating pressure upstream of the regulator cannot exceed the maximum allowable operating pressure of the downstream devices.

### 6.3 Vent restrictor to ANSI/CSA

The vent restrictor complies with the requirements of ANSI Z21.18a-2010 and CSA6.3a-2010.

It is included with every GDJ..T T-product and screwed into the breather orifice in place of the vent screen.

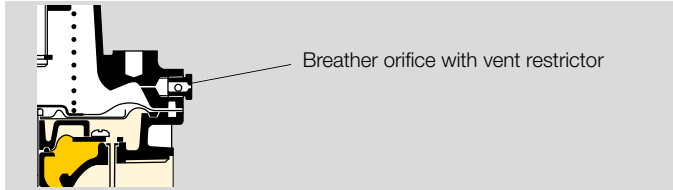

In normal operation, the vent restrictor ensures venting as does the vent screen. In the event of a sudden malfunction, a ball inside the vent restrictor is pressed onto the restrictor outlet and blocks the escaping gas.

Pressure		Flow rate			
mbar	psig	Natural gas		Air	
		m <sup>3</sup> /h	ft <sup>3</sup> /h	m <sup>3</sup> /h	ft <sup>3</sup> /h
34.5	0.5	0.028	0.995	0.036	1.284
69	1.0	0.028	0.995	0.036	1.284
103	1.5	0.031	1.085	0.040	1.401
138	2.0	0.041	1.447	0.053	1.869
345	5.0	< 0.056	< 2.0	0.071	< 2.5

The vent restrictor is designed so that the flow rate is between 1 and 2.5 ft<sup>3</sup>/h (natural gas with a relative density of 0.64) in the event of a malfunction.

### 6.4 Feedforwarding the furnace chamber pressure

If furnace pressure varies, a combustion chamber control line can be connected to the breather orifice (GDJ..R = Rp ¼, GDJ..N = NPT ¼) in place of the vent screen in order to maintain a constant burner capacity.

This application is only permitted for a maximum furnace chamber pressure between 0 and +100 mbar and for slow pressure changes.

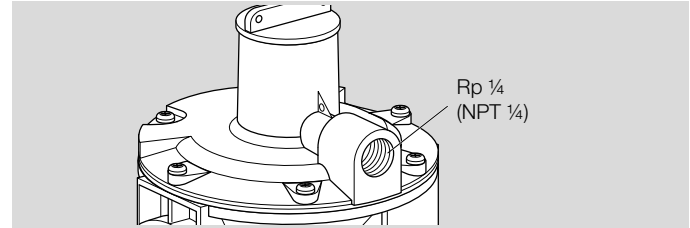

## 7 Technical data

Gas types: natural gas, town gas, LPG (gaseous) and biogas (max. 0.02 %-by-vol. H<sub>2</sub>S), GDJ..L also for air. The medium must be dry in all temperature conditions and must not contain condensate.

Inlet pressure range up to 400 mbar (5.8 psig).

Outlet pressure ranges:

GDJ 15: 2 to 55 mbar (0.8 to 22 "WC),

GDJ 20 – 40: 5 to 160 mbar (2 to 64 "WC),

GDJ 50: 5 to 100 mbar (2 to 40 "WC).

The regulators are preset at the factory to 20 mbar.

Turndown: 10:1.

Ambient temperature: -20 to +60°C (-4 to +140°F).

No condensation permitted.

Long-term use in the upper ambient temperature range accelerates the ageing of the elastomer materials and reduces the service life.

Storage temperature: -20 to +40°C (-4 to +104°F).

Valve housing: aluminium.

Valve seat: aluminium.

Valve disc: plastic.

Valve disc seal: NBR.

Diaphragms: NBR.

When used for air: special version.

Internal thread: Rp to ISO 7-1.

## 7.1 Dimensions

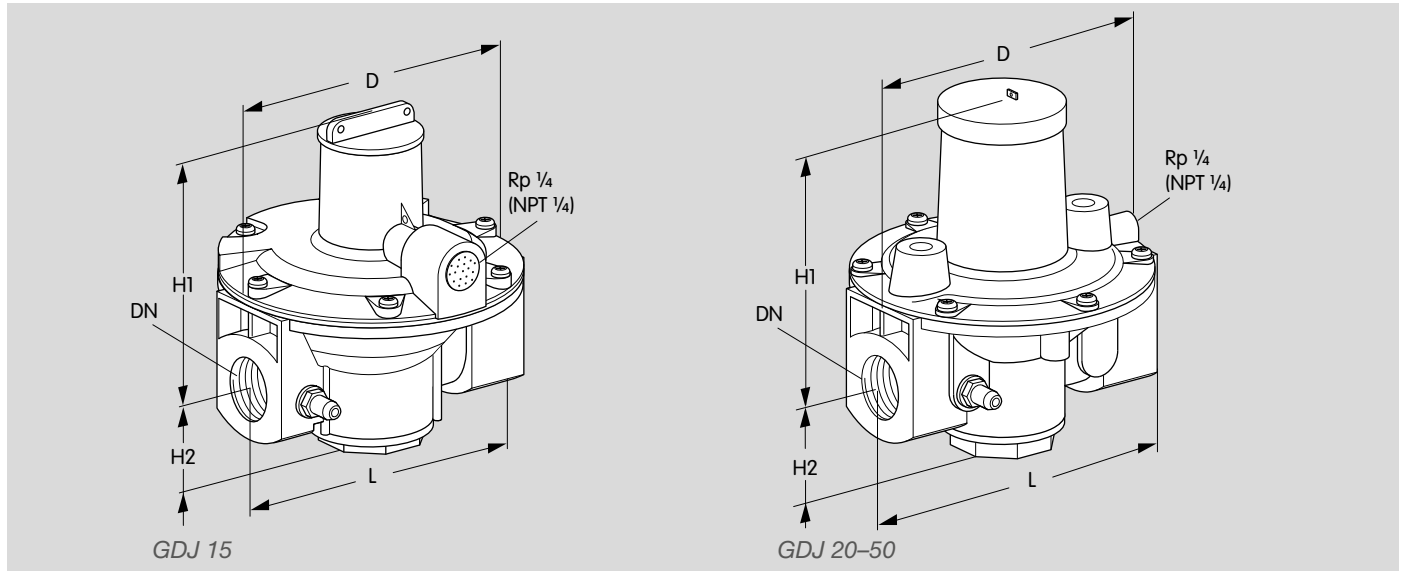

Type	Dimensions										Weight		
	DN	Connection		L		H1		H2		D		kg	lbs
mm		inch	mm	inch	mm	inch	mm	inch	mm	inch			
GDJ 15, GDJ 15T	15	Rp 1/2	1/2 NPT	100	3.93	90	3.54	30	1.18	100	3.93	0.6	1.32
GDJ 20, GDJ 20T	20	Rp 3/4	3/4 NPT	125	4.92	132	5.20	34	1.34	134	5.28	1	2.20
GDJ 25, GDJ 25T	25	Rp 1	1 NPT	125	4.92	132	5.20	34	1.34	134	5.28	1	2.20
GDJ 40, GDJ 40T	40	Rp 1 1/2	1 1/2 NPT	155	6.10	149	5.87	45	1.77	185	7.29	1.9	4.19
GDJ 50, GDJ 50T	50	Rp 2	2 NPT	200	7.87	167	6.57	52	2.05	234	9.21	3.1	6.82

## 7.2 GDJ spring table

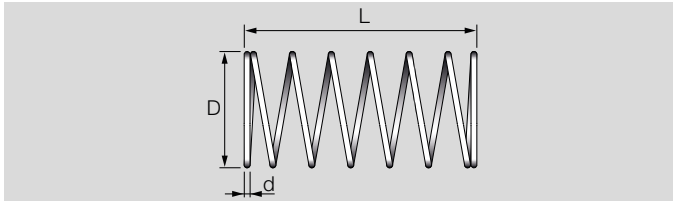

Outlet pressure		Spring marking	[mm]			Coils	Order No.
mbar	"WC		D [mm]	d [mm]	L [mm]		
<b>GDJ 15</b>							
2–16	0.8–6.4	yellow	21.84	1.2	42.1	10	03089075
10–20	4.0–8.0	black	21.64	1.2	54.4	11.5	03089076
16–28 <sup>1)</sup>	6.4–11.3	orange	21.84	1.2	63.5	11	03089077
22–40	8.8–16.1	brown	21.95	1.3	65.1	10.5	03089078
40–55	16.1–22.1 <sup>2)</sup>	light green/light blue	20.92	1.4	40	6.5	03089079
<b>GDJ 20, GDJ 25</b>							
5–15	2.0–6.0	dark green/light blue	36.90	2.0	64.4	11	03089121
12.5–25 <sup>1)</sup>	5–10.1	black	36.03	2.0	76	11	03089122
22.5–35	9.0–14.1	dark green/brown	36.90	2.0	80.3	7.75	03089123
30–50	12.1–20.1	dark green/orange	37.08	2.2	83.1	8	03089124
45–65	18.1–26.1	black/light green	36.59	2.3	81.9	8.75	03089125
60–80	24.1–32.1	red/orange	36.01	2.3	119	12	03089126
75–100	30.2–40.2 <sup>2)</sup>	pink/gold	36.50	2.5	80	6.8	03089127
100–160	40.2–64.3	yellow/orange	36.29	2.8	74	5.2	03089128
<b>GDJ 40</b>							
5–15	2.0–6.0	black/light blue	36.43	2.2	70.5	8.5	03089129
12.5–25 <sup>1)</sup>	5–10.1	black/light green	36.59	2.3	81.9	8.75	03089130
22.5–35	9.0–14.1	silver/orange	36.59	2.3	97.8	8.5	03089131
30–50	12.1–20.1	black/brown	36.59	2.3	98.3	7.25	03089132
45–65	18.1–26.1	red/gold	36.28	2.6	109	9.9	03089133
60–80	24.1–32.1	black/orange	36.80	2.8	106	8	03089134
75–100	30.2–40.2 <sup>2)</sup>	pink/silver	36.30	2.8	100	7	03089135

## Technical data

Outlet pressure		Spring marking	[mm]			Coils	Order No.
mbar	"WC		D [mm]	d [mm]	L [mm]		
100–160	40.2–64.3	grey/gold	36.60	3.1	101	5.75	03089136
<b>GDJ 50</b>							
5–15	2.0–6.0	white/brown	36.59	2.3	76.8	8	03089137
12.5–25 <sup>1)</sup>	5–10.1	white/dark blue	36.59	2.3	81.3	6	03089138
22.5–35	9.0–14.1	white/dark green	36.89	2.6	97.3	7.5	03089139
30–50	12.1–20.1	white/red	36.80	2.8	94.3	7	03089140
45–65	18.1–26.1	white/orange	36.70	3.0	93.3	6.5	03089141
60–80	24.1–32.1	dark blue/grey	36.74	2.9	138.7	9	03089142
75–100	30.2–40.2 <sup>2)</sup>	grey/gold	36.60	3.1	101	5.75	03089143

<sup>1)</sup> GDJ standard equipment, <sup>2)</sup> GDJ..T standard equipment  
Dispatch complete with label for changed outlet pressure.

## 7.3 Converting units

See [www.adlatus.org](http://www.adlatus.org)

## **8 Maintenance cycles**

At least once a year, at least twice a year in the case of biologically produced methane.



## Fore more information

The Honeywell Thermal Solutions family of products includes Honeywell Combustion Safety, Eclipse, Exothermics, Hauck, Kromschroder and Maxon. To learn more about our products, visit [ThermalSolutions.honeywell.com](http://ThermalSolutions.honeywell.com) or contact your Honeywell Sales Engineer.

Elster GmbH  
Strotheweg 1, D-49504 Lotte  
T +49 541 1214-0  
[hts.lotte@honeywell.com](mailto:hts.lotte@honeywell.com)  
[www.kromschroeder.com](http://www.kromschroeder.com)

Global centralized service deployment coordination:  
T +49 541 1214-365 or -555  
[hts.service.germany@honeywell.com](mailto:hts.service.germany@honeywell.com)

© 2019 Elster GmbH

We reserve the right to make technical modifications in the interests of progress.

**Honeywell**

**krom  
schroder**