

**Honeywell**

**MAXON**

# Series NP-LE AIRFLO<sup>®</sup>

## IN-DUCT FIRING LINE BURNER

TECHNICAL CATALOG

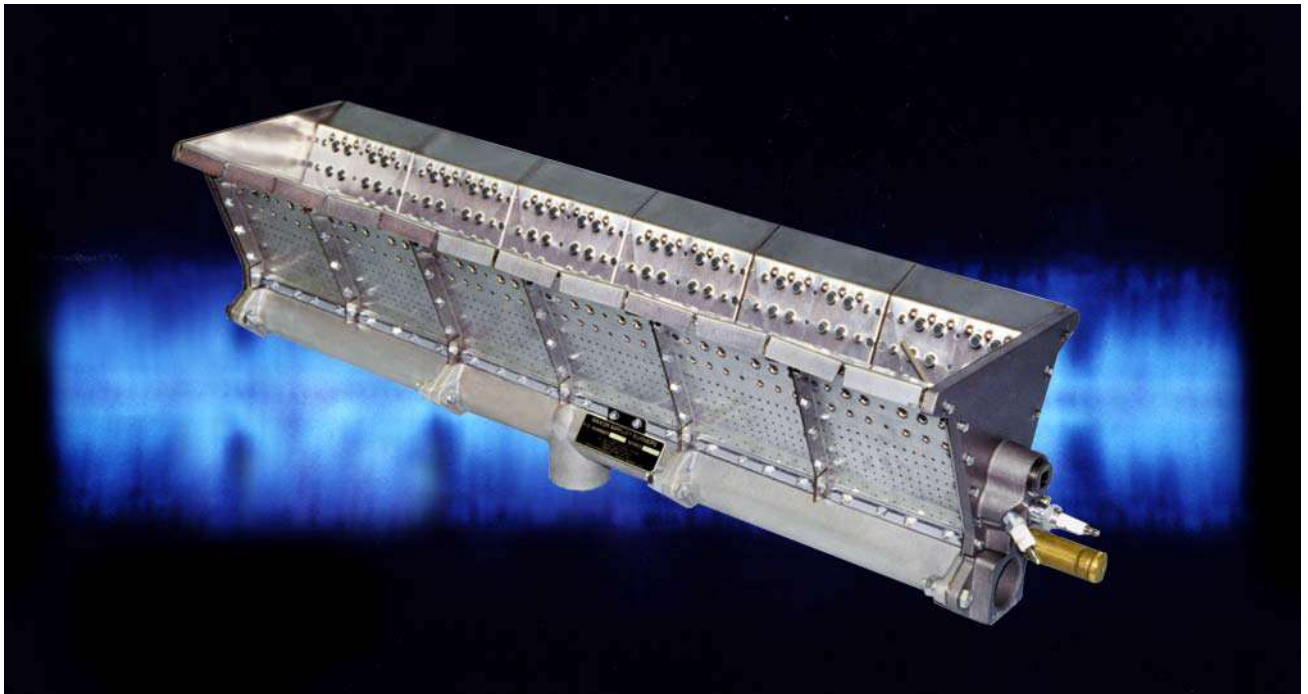

- Designed for direct-fired make-up air and process applications
- Improved emissions performance over MAXON's standard "NP" AIRFLO<sup>®</sup> Burner, with significantly lower levels of CO and NO<sub>2</sub>
- High capacity - up to 300 kW/ft
- Short flame length
- Available in low pressure version and corrosion-resistant materials



32M-03006-02

# PRODUCT DESCRIPTION

## NP-LE AIRFLO<sup>®</sup> principle

- 1) fresh air
- 2) fuel / gas
- 3) hot air

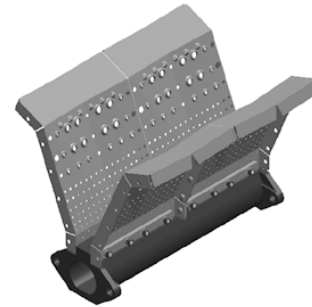
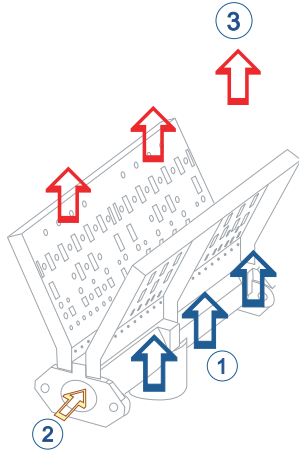

MAXON Series NP-LE AIRFLO<sup>®</sup> burners consist of a robust cast-iron or aluminum burner body (which serves as the gas manifold) drilled to discharge the gaseous fuel between diverging stainless steel mixing plates.

The burners are mounted directly into the air stream being heated. Gaseous fuel is injected into the process air stream. The unique designed V-shaped burner mixing plates are intimately mixing both gas and process air together.

All available heat from the gaseous fuel is released directly into the air stream.

The required oxygen for the combustion is progressively drawn from the process air stream.

Carefully controlled aeration patterns provide progressive mixing, superior cross-ignition, flame retention and odor-free combustion.

Air velocities across the burner (the key to successful operation) are established by the use of profile plates.

Optimum performance demands that air velocities be uniform across the entire burner.

## System components normally used in conjunction with a MAXON NP-LE AIRFLO® burner application

- 1) AIRFLO® burner
- 2) profile plate
- 3) combustion chamber
- 4) intake louvers
- 5) main volume fan
- 6) sequencing control panel
- 7) differential air pressure switch
- 8) high temperature protection
- 9) safety shut-off valves
- 10) vent valve
- 11) gas filter
- 12) control valve
- 13) pilot gas train

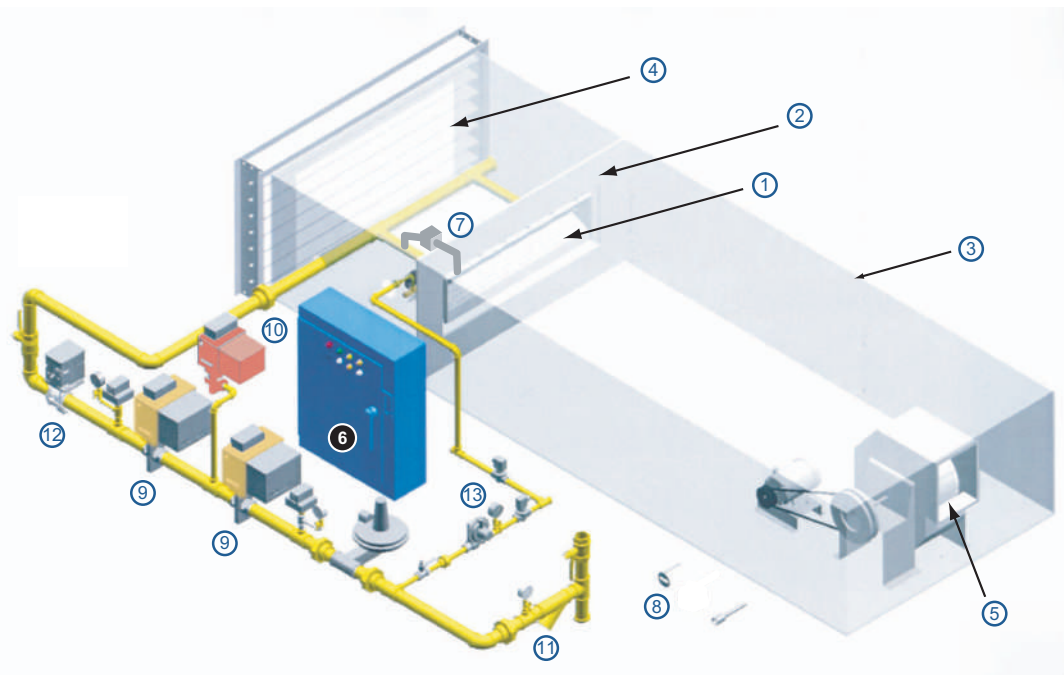

### Available product sizes

#### FOR MAKE-UP AIR HEATING

For fresh, ambient air heating, the NP1-LE and NP2-LE AIRFLO® burner types provide a nominal capacity of 300 kW per foot with a turndown of 30:1. NP2-LE AIRFLO® burners are selected when gas supply pressures are too low for NP1-LE burners.

#### FOR PROCESS AIR HEATING

NP1-LE and NP2-LE AIRFLO® burners may be used if temperature rise does not exceed 400°C. Upstream process air temperatures should not exceed 315°C. Downstream temperatures should be limited to 540°C.

NP1-LE and NP2-LE AIRFLO® burners can be supplied with special aluminum alloy bodies for corrosive applications. The use of aluminum alloy bodies limits the

maximum allowed upstream process air temperature to 230°C. Downstream temperature should not exceed 450°C.

#### Materials of construction

NP1-LE AIRFLO® burners are available in three material choices:

- Standard - cast iron body and end plates
- AL - aluminum body with cast iron end plates
- ALSS - aluminum body and back-up bars, nickel plated end plates, stainless steel fasteners

NP2-LE AIRFLO® burners are available in two material choices:

- Standard - cast iron body and end plates
- AL - aluminum body with cast iron end plates

**Typical burner data**

**Fuel: natural gas at 15°C with 10.9 kWh/Nm<sup>3</sup> HHV - sg = 0.6 [1]**

**Combustion air: 15°C - 21% O<sub>2</sub> - 50% humidity - sg = 1.0 [1]**

**Stated pressures are indicative. Actual pressures are a function of air humidity, altitude, type of fuel and gas quality.**

Burner size		NP1-LE	NP2-LE
Maximum capacity per foot [2] [5]	kW HHV	300	300
Minimum capacity per foot [3] [5]	kW HHV	7	7
Natural gas pressure required [2]	mbar	31.7	15.2
Flame length [2]	mm	150 - 700	150 - 700
Air velocity required [4]	m/s	8.5 - 15	8.5 - 15
Pressure drop process air [4]	mbar	0.75 - 2.5	0.75 - 2.5
Turndown		30:1	30:1
Fuel gas		natural gas, propane and butane	

[1] sg (specific gravity) = relative density to air (density air = 1.293 kg/Nm<sup>3</sup>)

[2] Higher gas pressure will result in higher heat release per unit and longer flame length. Contact MAXON for more information and performance limits in your particular application. Also see note [3].

[3] Absolute minimum capacity at optimal air flow (velocity and distribution). Minimum capacity influenced by air velocity and burner application. Contact MAXON for your specific installation.

[4] Air velocity for optimal burner performance. The burner will be able to operate within a given range of air velocity. The higher the velocity at a given gas pressure, the shorter the flame length, and the higher the pressure differential of the process air across the burner. 1 foot = 305 mm

## APPLICATIONS

Series NP-LE AIRFLO<sup>®</sup> burners are designed for direct heating of fresh, clean air for low and medium temperature air heating applications.

Typical low temperature applications include humidity-controlled dual stage paint, spray booths, general make-up air applications, packaged units, door heaters, grain drying, malt drying, etc.

Typical high temperature process air applications include spray dryers, chemical dryers, fresh air oven heating, drying, baking and curing operations, metal parts finishing and all fresh air heating applications up to 540°C.

These burners can also be mounted downstream of a steam or hot water coil thus bringing the air to a higher temperature. This can boost the capacity of an existing installation.



Direct air heating with NP-LE AIRFLO<sup>®</sup> burners in continuous flow dryers for grain

# DIMENSIONS AND WEIGHTS

- 1) NP1-LE AIRFLO<sup>®</sup> burner
- 2) NP-LE 12" straight section
- 3) Typical end view

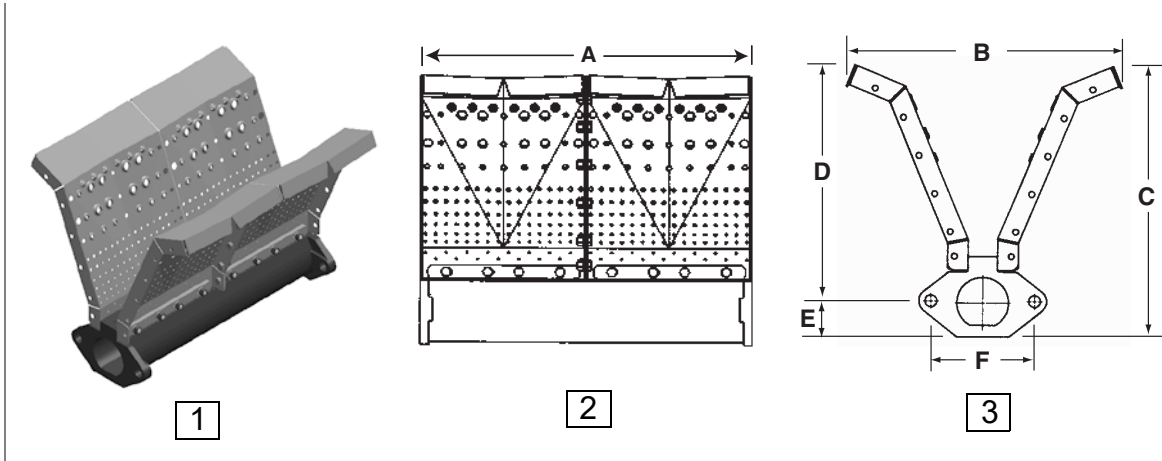

Dimensions in mm unless stated otherwise							
Burner type	A	B	C	D	E	F	Weight kg
NP-LE AIRFLO <sup>®</sup> burner	305	254	251	218	33	97	3.6

## Typical emissions (burners only)

MAXON Series NP-LE AIRFLO<sup>®</sup> burners are especially designed to meet the high demands of most of the local standards on air quality of direct fired make-up air and space heating applications worldwide.

If correctly used within the performance limits as described on page 4-21.6-4, both CO and NO<sub>x</sub> will remain far below the limits as determined in most standards.

Note that incorrect use or use outside the performance limits may seriously affect emissions.

Exact emissions performance may vary in your application. Contact MAXON for information on installation-specific estimates or guarantees. No guarantee of emissions is intended or implied without specific written guarantee from MAXON.

Read "Specifications of NP-LE AIRFLO<sup>®</sup> burners" for complete information on these burner types.

## Specifications of NP-LE AIRFLO<sup>®</sup> burners

**DIFFERENTIAL GAS PRESSURE AT BURNER INLET**  
For burner capacity - 300 kW/ft (HHV)

Fuel	NP1-LE	NP2-LE
Natural gas ( 10.9 kWh/Nm <sup>3</sup> HHV, d = 0.6)	31.7 mbar	15.2 mbar
Propane ( 25.79 kWh/Nm <sup>3</sup> HHV, d = 0.6)	12.8 mbar	6.2 mbar
Butane	7.7 mbar	3.7 mbar

### NOTES:

- For other capacities per foot or gases with different heating values and/or specific weights as shown in the above table, values for differential gas pressure will behave according to the normal laws of physics.
- Listed values are approximate net pressures at burner inlet, NOT taking into account any losses in piping/gas manifolds, etc.

# Maximum burner capacities

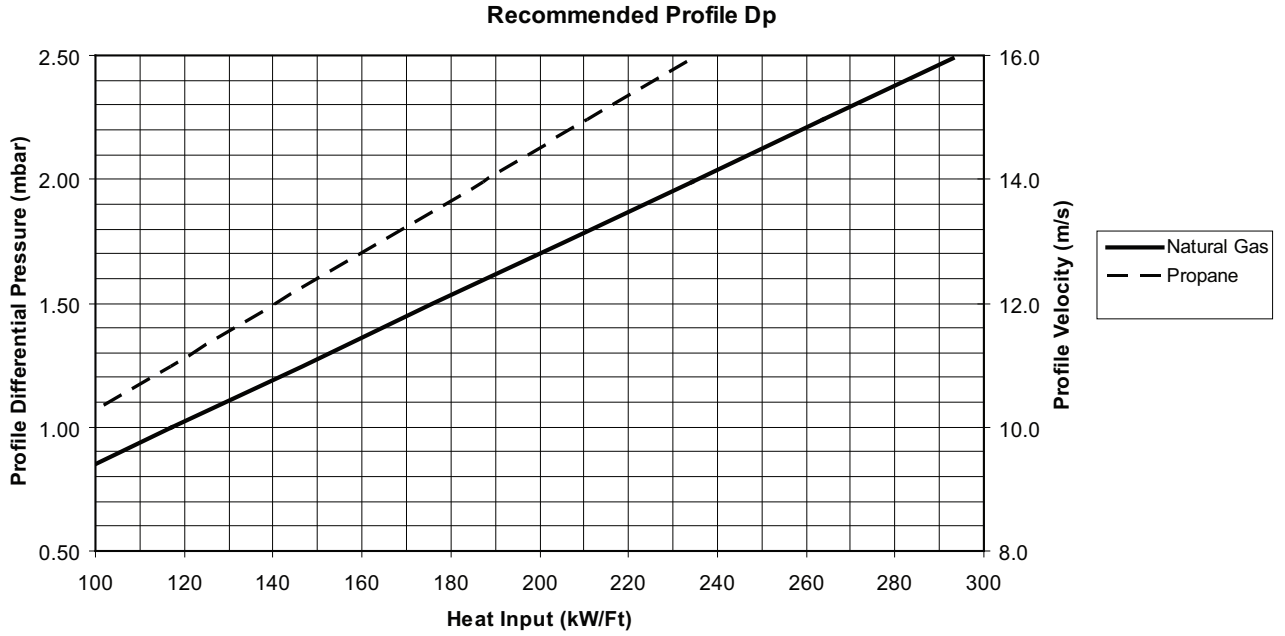

**NOTES:**

- Air stream velocity across and through your burner’s mixing plates must be kept uniform and within desired limits by use of a silhouette profile plate through which the burner fires. Refer to page 4-21.6-10 for more details on sizing of this profile plate.

- Pilot capacities are nominally rated at 7.3 kW with natural gas differential pressure of 10 mbar to 15 mbar.

Suitable for natural gas, propane and propane-air mixtures. Contact MAXON for applications on butane or other gases than specified here.

## Fuel pressure requirements

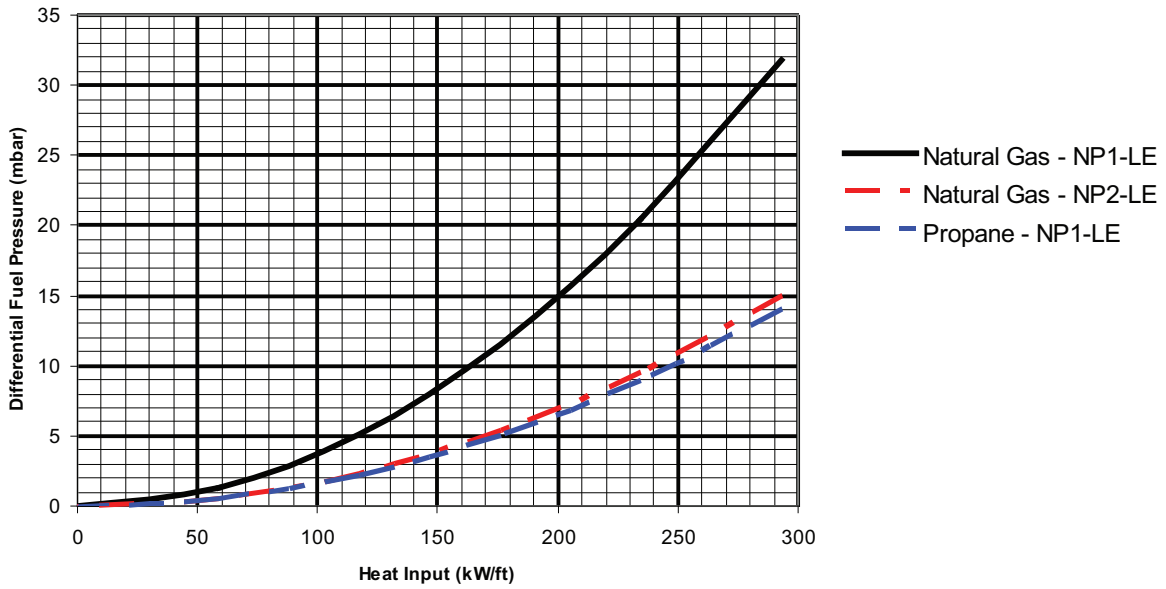

## Flame length

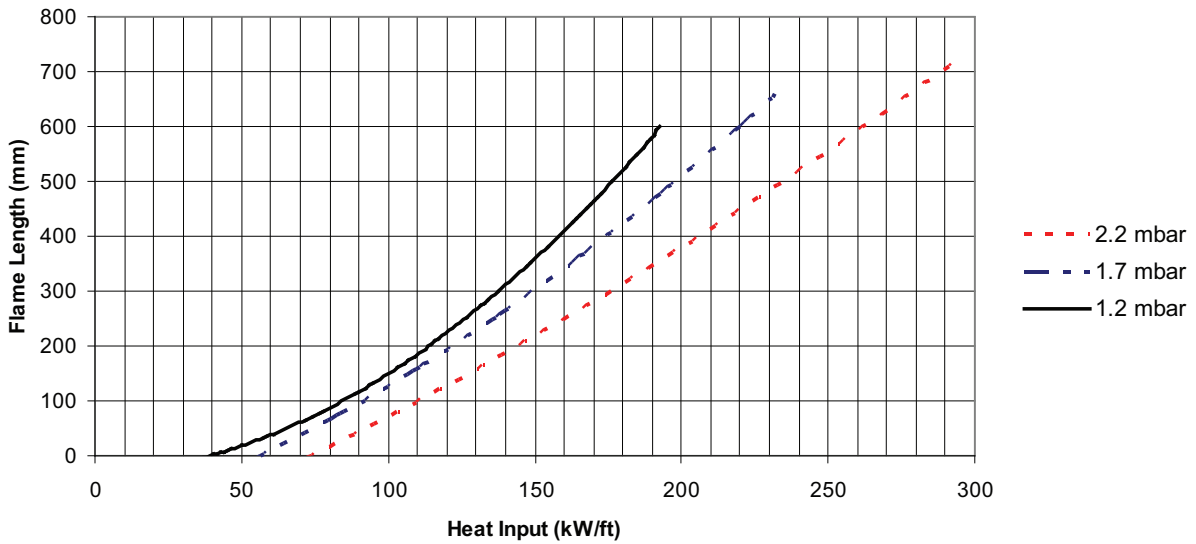



## Materials of construction

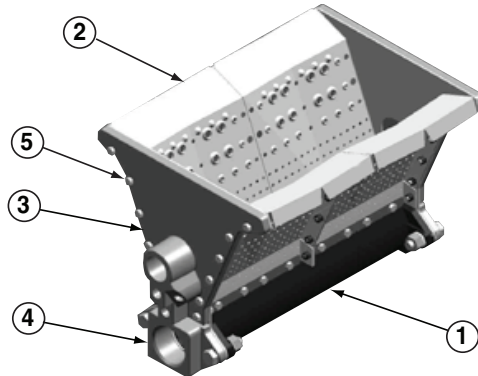

Burner part		NP1-LE	NP1-LE AL	NP1-LE ALSS	NP2-LE	NP2-LE AL
1	Burner body	Cast iron	Aluminum	Aluminum	Cast iron	Aluminum
2	Mixing plates	430 SS (1.4016)	430 SS (1.4016)	430 SS (1.4016)	430 SS (1.4016)	430 SS (1.4016)
3	End plates: upper [1]	Cast iron	Cast iron	Plated cast iron	Cast iron	Cast iron
4	End plates: lower	Cast iron	Cast iron	Plated cast iron	Cast iron	Cast iron
5	Fasteners	Plated	Plated	Stainless steel	Plated	Plated

[1] LT (low temperature) pilot upper end plate is steel

## Selection criteria

### Air stream velocity

Air stream velocity across and through the burner's mixing plates must be kept uniform and within desired limits by use of a silhouette profile plate through which the burner fires. A 152 mm (minimum) profile plate should be installed surrounding the interior duct walls at the leading edge of the burner mixing plates.

- 1) Profile plate
- 2) Burner front
- 3) Support
- 4) Burner mounting bracket

- A Minimum 152 mm
- B Minimum 152 mm
- X 35 mm

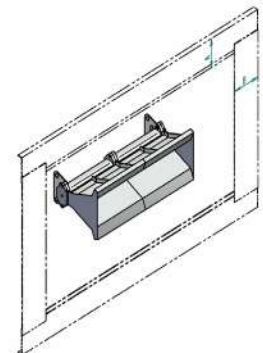
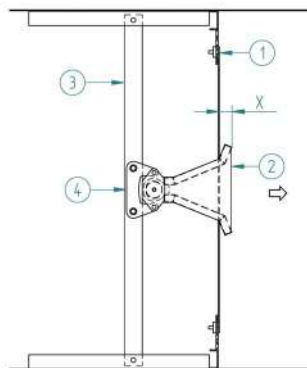

Optimal process air velocities for Series NP-LE AIRFLO® burners are shown in the graph on page 4-21.6-7. Velocities in m/s are measured with a velometer direct in the duct at the plane of the profile plate and leading edge of burner mixing plates (see above sketch).

To determine the profile opening area, add the burner displacement area (cm<sup>2</sup>/section) from table on page 4-21.6-12 for the complete burner assembly to the "Net Free Area" of the duct:

$$\text{"Net free area" of duct (cm}^2\text{)} = \frac{\text{Fan volume (m}^3\text{(st)h)}}{\text{Velocity (m/s x 3600)}} \times 10,000 = \text{.....cm}^2$$

Effective displacement adjustment (cm<sup>2</sup>) = length of mixing plate adjacent to profile plate (cm) X 4.7

m<sup>3</sup>(st)/h = fan volume at 288 Kelvin and 1 atmosphere

Effective burner displacement (cm<sup>2</sup>) = sum of section areas (from table on 4-21.6-12) – effective displacement adjustment

- 1) Mixing plate
- 2) Profile opening

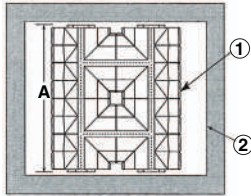

A = 610 mm

(2) 36" back inlet sections

$$\text{Net free area (cm}^2\text{)} + \text{burner displacement (cm}^2\text{)} = \text{profile area (cm}^2\text{)}$$

The relation between velocity and pressure differential across the burner slightly differs with the ratio between net profile area and total duct section.

Velocities should always be confirmed and established by use of a velometer on actual field site installation.

## Velocity factors

(fresh air 15°C)

Velocity factors (as measured with pitot tube K=1.0)														
Desired velocity across burner at profile plate opening (m/s)	8	9	10	11	12	13	14	15	16.5	17.8	19	20	22.9	25.4
Approximate velocity pressure reading at profile plate (mbar)	0.4	0.5	0.6	0.7	0.9	1.0	1.2	1.4	1.6	1.9	2.2	2.5	3.1	3.9
Approximate corresponding static pressure drop across profile plate (mbar)	0.6	0.8	1.0	1.2	1.4	1.7	1.9	2.3	2.5	3.1	3.5	4.0	5.0	6.2

- Differential air pressures are measured via pressure test points located 150 mm upstream and 150 mm downstream of the profile plate, near the duct wall at 100 mm into the duct (see sketch on page 4-21.6-10)
- Typical data which may not represent precise pressure drops for all design cases.

Refer to the table below as a guideline for natural gas, based on a maximum capacity limitation of 300 kW/ft. The number of gas inlets should be reconsidered for gases different from natural gas (for example gases with lower calorific value). Contact MAXON for more details.

### INLET FEED LIMITATIONS

The maximum number of units of burner per gas inlet connection should be limited in order to guarantee correct gas distribution inside the burner manifold. Insufficient or badly distributed gas inlet connections may affect flame length, pollutant emissions and temperature distribution downstream of the burner.

Burner	NP1-LE and NP2-LE
1-1/4" end inlet flange	equal to or less than 4 ft
1-1/2" back inlets [1]	equal to or less than 5 ft

[1] For 305 x 305 x 305 mm back inlet sections; not more than 150 mm section off any one leg

## Burner sections

Burner type	NP1-LE	NP1-LE AL	NP1-LE ALSS	NP2-LE	NP2-LE AL
	Cast iron body, cast iron end plates	Aluminum body, cast iron end plates	Aluminum body & back-up bars, nickle plated end plates, stainless steel fasteners	Cast iron body, cast iron end plates	Aluminum body, cast iron end plates
Description	Designation				
150 mm straight section	NP-I-LE-6	NP-I-LE-6 AL	NP-I-LE-6 AL W/SS	NP-II-LE-6	NP-II-LE-6 AL
305 mm straight section	NP-I-LE-12	NP-I-LE-12 AL	NP-I-LE-12 AL W/SS	NP-II-LE-12	NP-II-LE-12 AL
455 mm straight section	NP-I-LE-18	NP-I-LE-18 AL	NP-I-LE-18 AL W/SS	NP-II-LE-18	N/A
610 mm straight section	NP-I-LE-24	NP-I-LE-24 AL	NP-I-LE-24 AL W/SS	NP-II-LE-24	N/A
150 mm x 150 mm elbow section	NP-I-LE-L	N/A	N/A	NP-II-LE-L	N/A
305 mm x 150 mm tee section	NP-I-LE-T	NP-I-LE-T AL	NP-I-LE-T AL W/SS	NP-II-LE-T	NP-II-LE-T AL
305 mm back inlet section	NP-I-LE-12B	NP-I-LE-12B AL	NP-I-LE-12B AL W/SS	NP-II-LE-12B	NP-II-LE-12B AL
915 mm back inlet section	NP-I-LE-36B	NP-I-LE-36B AL	NP-I-LE-36B AL W/SS	NP-II-LE-36B	N/A

N/A = not applicable

## Burner displacement and weight



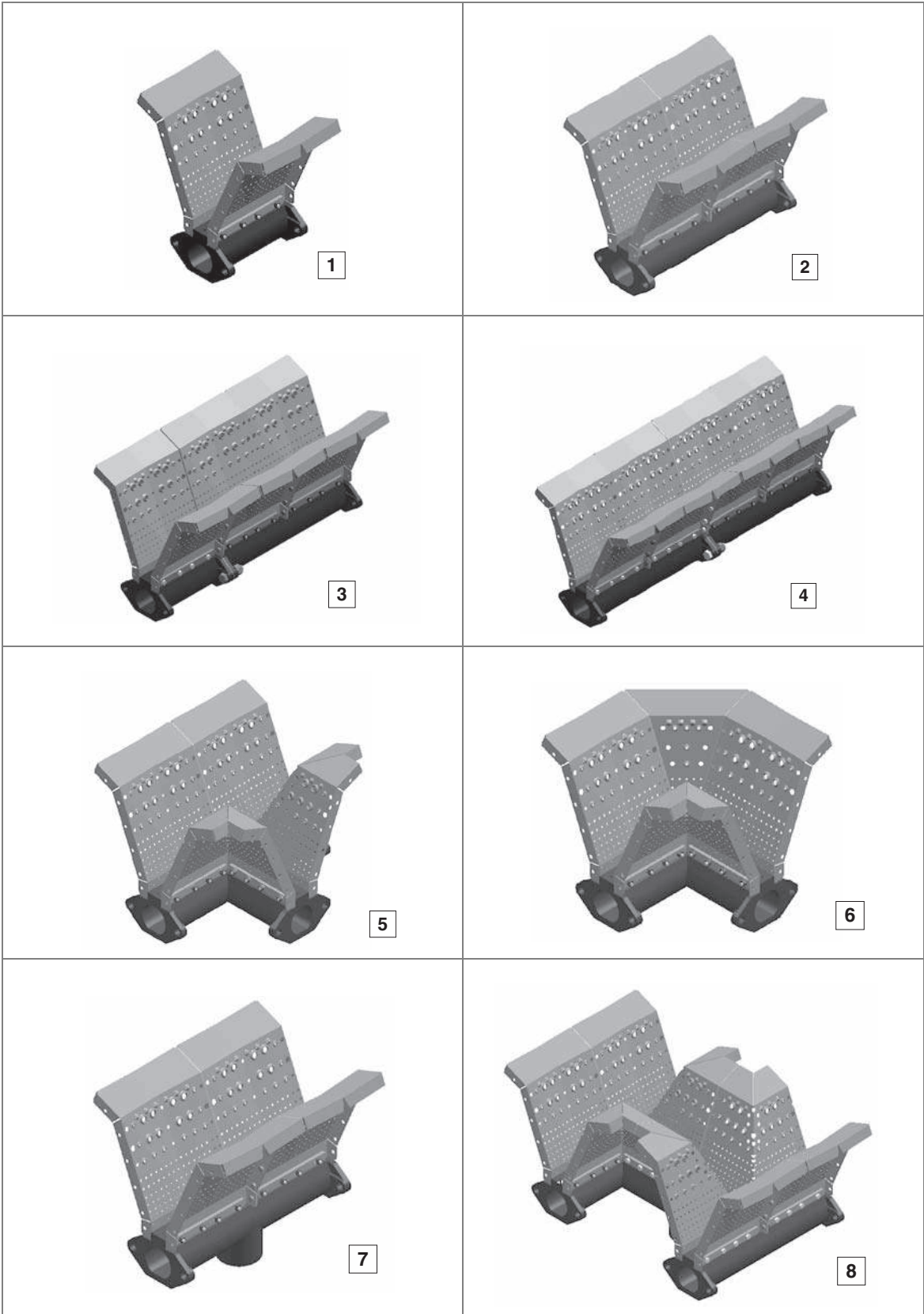





Burner type	NP1-LE		NP1-LE AL		NP1-LE ALSS		NP2-LE		NP2-LE AL	
	Cast iron body, cast iron end plates		Aluminum body, cast iron end plates		Aluminum body & back-up bars, nickle plated end plates, stainless steel fasteners		Cast iron body, cast iron end plates		Aluminum body, cast iron end plates	
Description	Area cm <sup>2</sup> /section	Approx. weight kg	Area cm <sup>2</sup> /section	Approx. weight kg	Area cm <sup>2</sup> /section	Approx. weight kg	Area cm <sup>2</sup> /section	Approx. weight kg	Area cm <sup>2</sup> /section	Approx. weight kg
150 mm straight section	372	7.3	372	5.9	372	5.9	372	7.3	372	5.9
305 mm straight section	743	10	743	7.3	743	8.6	743	10	743	7.2
455 mm straight section	1115	12.7	1115	9	1115	11.3	1115	12.7	N/A	N/A
610 mm straight section	1486	15.4	1486	10.8	1486	14	1486	15.4	N/A	N/A
150 mm x 150 mm elbow section	650	10		N/A	N/A	N/A	650	10	N/A	N/A
305 mm x 150 mm tee section	836	11.3	836	8.2	836	10	836	11.3	836	8.2
305 mm back inlet section	743	10.4	743	7.7	743	9	743	10.4	743	7.7
915 mm back inlet section	1672	19	1672	12.2	1672	17.7	1672	19	N/A	N/A











- 1) NP\*-LE-6
- 2) NP\*-LE-12
- 3) NP\*-LE-18
- 4) NP\*-LE-24
- 5) NP\*-LE-T
- 6) NP\*-LE-L
- 7) NP\*-LE-12B
- 8) NP\*-LE-36B





## Pilots, end closures, and end inlet flange sets for Series NP-LE AIRFLO® burners

All open ends of burner assembly must be closed off with one of these end closures or pilots

Series NP-LE AIRFLO® burners			
Designation	Description	Model	Weight kg
PLN	Plain		0.9
PLN FI	Upper plain, lower fuel		0.9
O/O FR PLN	Upper pilot w/outwardly extending flame rod, lower plain		1.8
O/O FR FI	Upper pilot w/outwardly extending flame rod, lower fuel		1.8
LT PLN	Low temperature plain		1.4
LT PLN FI	Low temperature upper plain, lower fuel		1.4
LT PILT PLN	Low temperature upper pilot, lower plain		1.4
LT PILT FI	Low temperature upper pilot, lower fuel		1.4

Series NP-LE AIRFLO® burners			
Designation	Description	Model	Weight kg
I/O FR PLN	Upper pilot w/inwardley extending flame rod, lower plain		1.8
I/O FR FI	Upper pilot w/inwardly extending flame rod, lower fuel		1.8
1" 15DEG PLN	Upper pilot w/UV or FR port 1" NPT angled 15 degrees toward burner manifold, lower plain		1.8
1" 15DEG FI	Upper pilot w/UV or FR port 1" NPT angled 15 degrees toward burner manifold, lower fuel		1.8
MI PLN [1]	Plain		2.2
MI PLN FI [1]	Fuel inlet - ISO threaded		2.2
MI PLT PLN [1]	Pilot/scanner connection (1/2")		2.2
MI PLT FI ISO 1/2 [1]	Pilot/fuel inlet (1-1/2")/scanner connection (1/2") - ISO threaded		2.2

[1] For European customers - Material AISI304. MI end closures with pilot include spark ignitor and a fixed pilot gas orifice.

Series NP-LE AIRFLO® burners			
Designation	Description	Model	Weight kg
MI PLN FI NPT [1]	Fuel inlet - NPT threaded		2.2
MI PLT FI NPT 1/2 [1]	Pilot/fuel inlet (1-1/2")/scanner connection (1/2") - NPT threaded		2.2
MI PLT PLN [1]	Pilot/scanner connection (1")		2.2
MI PLT FI ISO 1 [1]	Pilot/fuel inlet (1-1/2")/scanner connection (1") - ISO threaded		2.2
MI PLT FI NPT 1 [1]	Pilot/fuel inlet (1-1/2")/scanner connection (1") - NPT threaded		2.2

[1] For European customers - Material AISI304. MI end closures with pilot include spark ignitor and a fixed pilot gas orifice.

## Process flows and oxygen content

Series NP-LE AIRFLO® burners are used only for the heating of fresh air in motion. Fresh air means air with 21% oxygen, at ambient temperature, or indirectly preheated via a steam or water coil. It is not recommended to use the burner in recirculating air systems.

NP-LE AIRFLO® burners may be used if temperature rise does not exceed 400°C.

Maximum temperature of the fresh air entering the burner is 315°C (230°C for burners with aluminum bodies).

Velocity and air flow at operating temperature must be uniform and constant for Series NP-LE AIRFLO® burners. Maximum temperature of the process air downstream of the burner is 540°C (450°C for burners with aluminum bodies).

## Piloting and ignition

Series NP-LE AIRFLO® burners are standard equipped with raw gas pilots to ignite the main flame. Pilot burner is incorporated in the burner end plate. Depending on the burner configuration, MAXON offers the choice between a complete range of pilot end plate sets. See tables on pages 4-21.6-14 through -16 for proper selection or contact MAXON for more detailed information.

Permanent pilot operation is not advised. Use main burner at minimum capacity for continuous operation. Also, direct ignition of the burner is possible, as long as acceptable by local regulations.

Use minimally 5000 V/200 VA ignition transformer for sparking of the spark ignitor. Contact MAXON for optional ignition equipment in hazardous locations.

Locate one pilot valve close enough to the pilot burner gas inlet to guarantee fast and reliable ignition of the pilot burner.

### Typical ignition sequence

- Pre-purge of the combustion chamber and installation, according to the applicable codes and the installation requirements.
- Gas control valve in minimum position.
- Pre-ignition (typically 2 s sparking in air). Open pilot gas valves and continue to spark (typically 5 s to 10 s).
- Stop sparking, continue to power the pilot gas valves and start flame detection. Trip the burner in case no flame detected from this point on.
- Check pilot flame stability (typically 5 s to 10 s to prove stable flame).
- Open main gas valves and allow enough time for the fuel gas to reach the burner (typically 5 s or the time that gas needs to reach the burner).
- Close the pilot gas valves.
- Release to modulation (allow modulation of the gas control valve).
- Above sequence shall be completed to include all required safety checks during the start-up of the burner (process and burner safeties).
- Be advised that some regional codes require proving of cross-ignition by sensing flame at both ends of long burners.

### Flame supervision

Standard connections for flame detection equipment are provided on the different end plates. Refer to selection tables on pages 4-21.6-14 through -16. Only use these connections for correct flame safeguarding. End plates have one connection for UV scanner (scanning parallel to the burner manifold) and flame rods (mounted parallel with burner body).

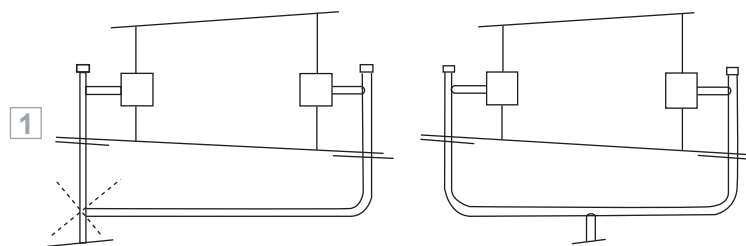

The pipe length between any manifold offtake or elbow and burner inlet should be at least 4 pipe diameters (see Fig. 2) of the nipple used or 2-1/2 times the main manifold pipe diameter, whichever is larger. ( $4 X < A > 2-1/2 Y$ )

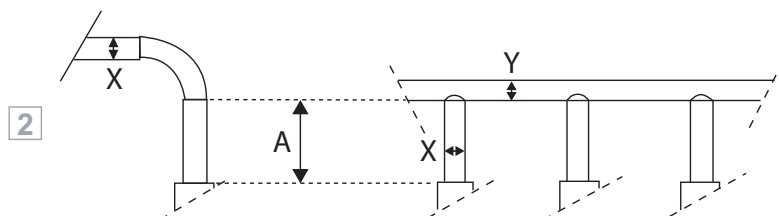

### Capacity control

Series NP-LE AIRFLO® burners are raw gas burners firing in a constant process air flow. Only gas flow to the burner is modulated by the use of a gas control valve. (MAXON Series “CV” valves, “A-”, “M-”, or “P-” SYNCHRO® valves, SMARTLINK CV).

Mechanically limit the minimum gas flow to the burner to guarantee stable flame at minimum fire. Assure that the burner is not overfired by limitation of the maximum position of the gas control valve. Changes in process air temperature, system back pressure and other parameters could cause failures or unsafe conditions if the burner control system is not designed to compensate for these. Contact MAXON for assistance.

### Manifolding

It is extremely important that the piping between the gas control valve (pipe train) and the burner inlet is correctly designed to ensure equal distribution of the gas to the burner inlet(s). Particularly with burners with multiple gas inlets, special attention should be given to this. Wrong choice of pipe diameters, incorrect construction of branch connections, wrong positions of elbow and insufficient straight pipe length to the burner inlet are some of the factors that may influence burner performance dramatically.

Below are a few general guidelines to take into consideration when designing the gas manifold. Contact MAXON for any questions or advice.

In case there are 2 burners on each side of a process air heater, the length of pipe of each side should be the same, so that the pressure in the 2 lines can equalize (see Fig. 1).



An offtake from a manifold should be straight and not in stream as shown in Fig. 3. Also the offtake should be welded on the manifold in such a way that the smaller pipe does not stick into the main manifold, (saddle weld) thus avoiding turbulence at the take-off point (see Fig. 4). The manifold should continue at least 2 pipe diameters beyond the last take-off (see Fig. 5).

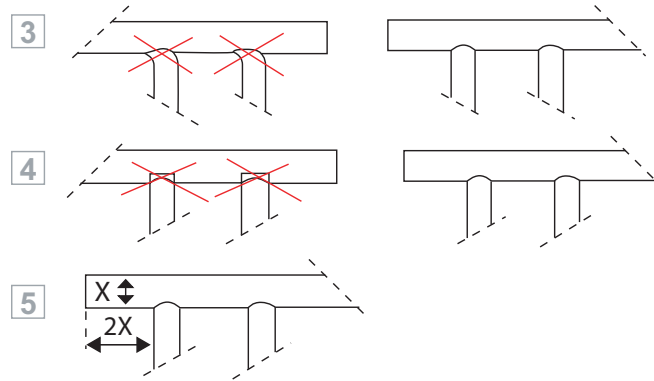

### Staged combustion

Series NP-LE AIRFLO<sup>®</sup> burners combine extremely stable operation with high performance on temperature distribution and on turndown.

By the use of staged combustion, turndown may even be dramatically increased.

Contact MAXON for more information.

### Fuels

Series NP-LE AIRFLO<sup>®</sup> burners are suitable for natural gas, propane and propane-air mixtures. Contact MAXON for other gases.

### Expected emissions

#### NO<sub>x</sub> Emissions Profile

Profile Dp 1.7 mbar  
NP1-LE

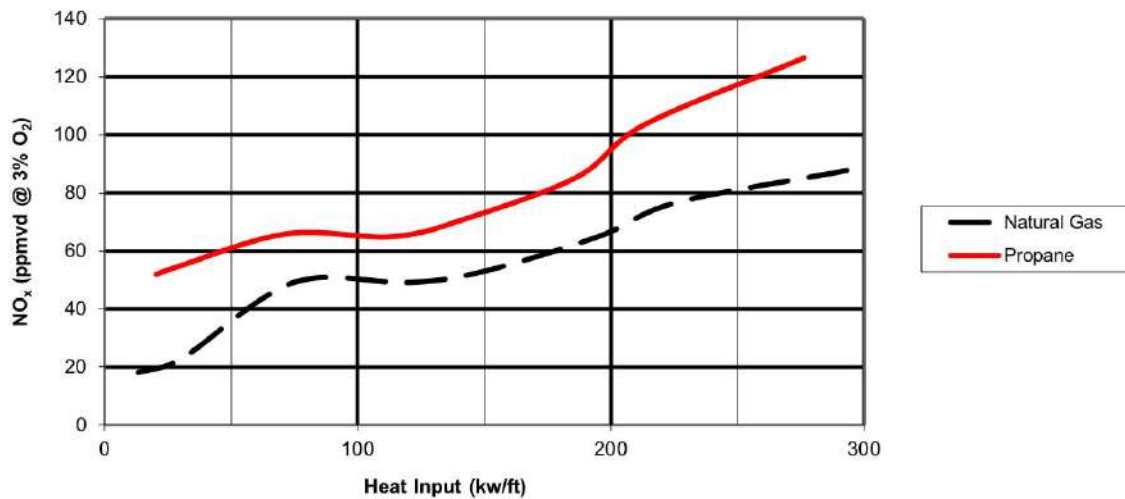

Note: Emission performance is application specific and may vary.

**CO Emissions Profile**  
 Profile Dp 1.7 mbar  
 NP1-LE

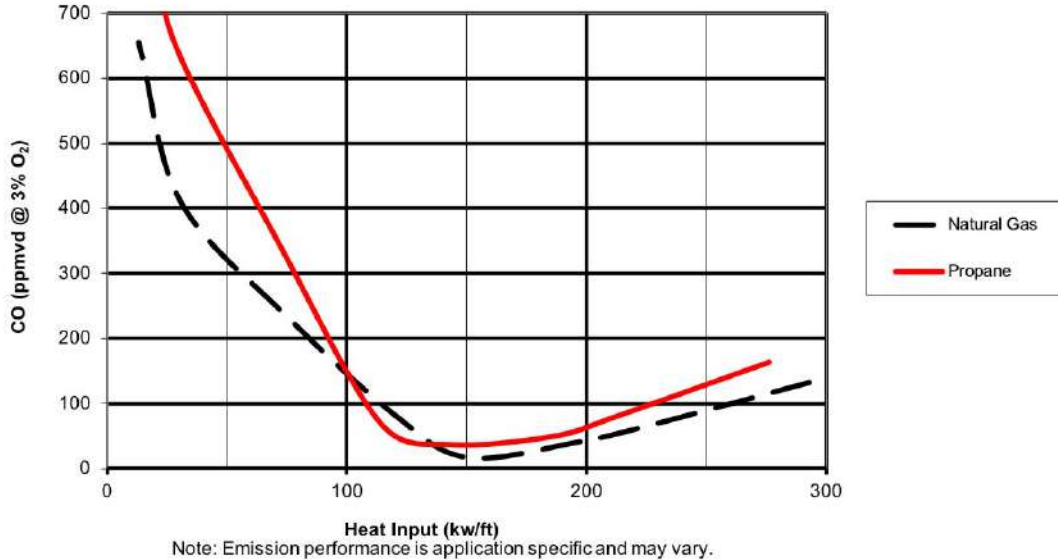

**NO<sub>2</sub> Emissions Profile**  
 Profile Dp 1.7 mbar  
 220 kW/ft Nominal Firing Rate NP1-LE

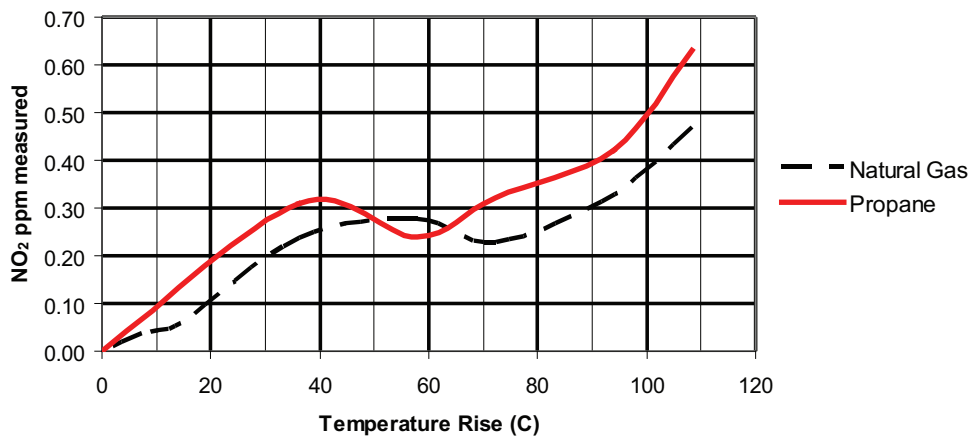

**CO Emissions Profile**  
 Profile Dp 1.7 mbar  
 220 kW/ft Nominal Firing Rate    NP1-LE

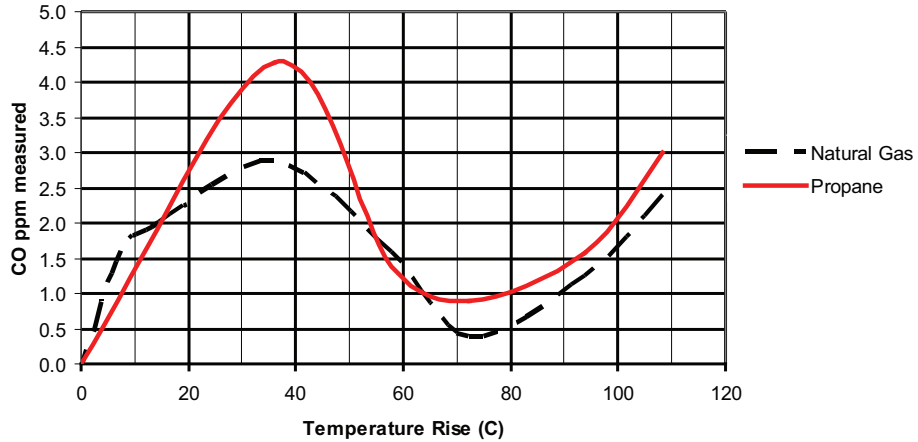

Emissions are, however, highly influenced by different burner and process-related factors such as type of gas, burner capacity, air stream velocity, process air humidity and temperature, relation duct/profile plate area, etc. We strongly advise to contact MAXON for evaluation of expected emissions on your typical application.

No guarantee of emissions is intended or implied on the above. Contact MAXON for specific evaluation of your process and application for a written guarantee of emissions.

# DIMENSIONS

## Burner sections

All NP-LE AIRFLO® burners shown are available in NP1-LE and NP2-LE versions. Use 1 or 2 instead of asterisk (\*) in burner designation when ordering.

NP1-LE and NP2-LE AIRFLO® burners are also available with aluminum bodies. See burner sections on page 4-21.6-12 for burner displacement and weights. Dimensions are identical.

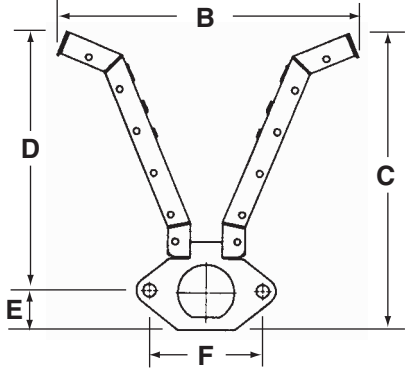
Dimensions in mm unless stated otherwise						
Burner type	B	C	D	E	F	
NP*-LE	254	251	218	33	97	

**Dimensions in mm unless stated otherwise**

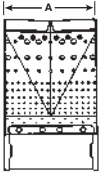
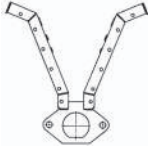
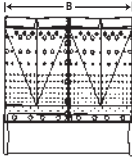
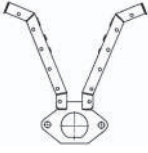
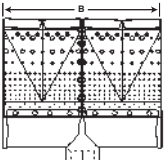
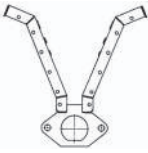
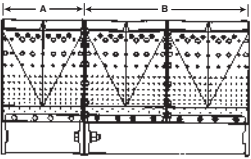
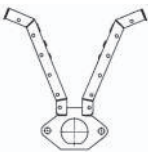
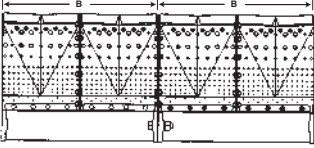
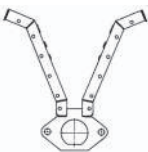
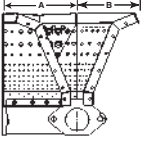
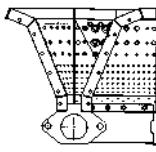
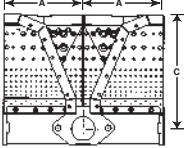
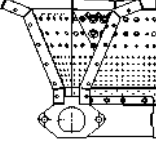
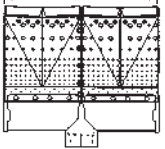
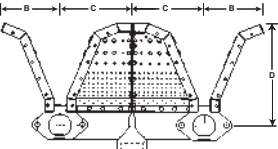
Designation	Dimensions										
NP*-LE-6			<table border="1" data-bbox="1208 348 1435 422"> <tr><td align="center">A</td></tr> <tr><td align="center">152</td></tr> </table>	A	152						
A											
152											
NP*-LE-12			<table border="1" data-bbox="1208 558 1435 632"> <tr><td align="center">B</td></tr> <tr><td align="center">305</td></tr> </table>	B	305						
B											
305											
NP*-LE-12B			<table border="1" data-bbox="1208 768 1435 842"> <tr><td align="center">B</td></tr> <tr><td align="center">305</td></tr> </table>	B	305						
B											
305											
NP*-LE-18			<table border="1" data-bbox="1208 978 1511 1052"> <tr><td align="center">A</td><td align="center">B</td></tr> <tr><td align="center">152</td><td align="center">305</td></tr> </table>	A	B	152	305				
A	B										
152	305										
NP*-LE-24			<table border="1" data-bbox="1208 1188 1435 1262"> <tr><td align="center">B</td></tr> <tr><td align="center">305</td></tr> </table>	B	305						
B											
305											
NP*-LE-L			<table border="1" data-bbox="1208 1398 1511 1472"> <tr><td align="center">A</td><td align="center">B</td></tr> <tr><td align="center">152</td><td align="center">127</td></tr> </table>	A	B	152	127				
A	B										
152	127										
NP*-LE-T			<table border="1" data-bbox="1208 1608 1511 1682"> <tr><td align="center">A</td><td align="center">C</td></tr> <tr><td align="center">152</td><td align="center">218</td></tr> </table>	A	C	152	218				
A	C										
152	218										
NP*-LE-36B			<table border="1" data-bbox="1208 1797 1511 1871"> <tr><td align="center">A</td><td align="center">B</td><td align="center">C</td><td align="center">D</td></tr> <tr><td align="center">305</td><td align="center">127</td><td align="center">152</td><td align="center">218</td></tr> </table>	A	B	C	D	305	127	152	218
A	B	C	D								
305	127	152	218								

# End plates for Series NP-LE AIRFLO® burners

**Plain upper end plate**

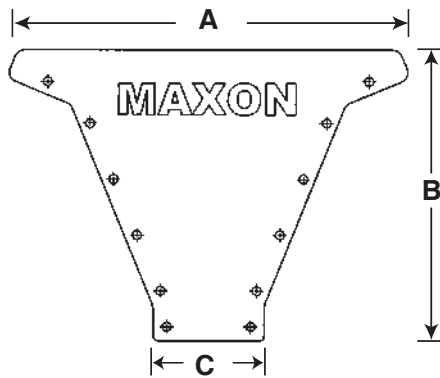

**Pilot upper end plate**

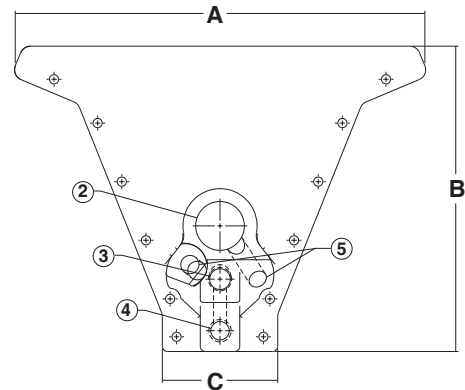

- 1) 1-1/2" NPT
- 2) 1" NPT UV scanner
- 3) Spark ignitor
- 4) 1/4" NPT pilot fuel/air
- 5) Flame rod
- 6) 1/8" NPT fuel pressure test connection
- 7) 1/2" NPT flame scanner

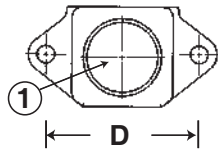

**Lower fuel inlet end plate**

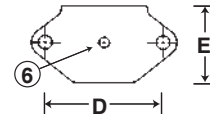

**Plain lower end plate**

**Pilot 1" angled upper end plate**

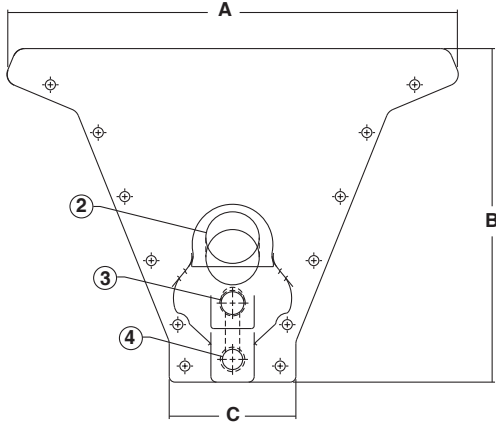

**LT pilot upper end plate**

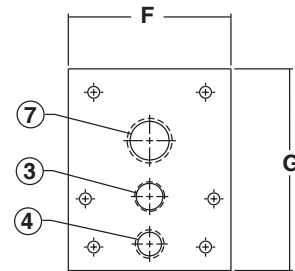

**Dimensions in mm unless stated otherwise**

A	B	C	D	E	F	G
246	183	69	97	64	76	97

# ACCESSORIES / REPLACEMENT ITEMS

## 14 mm spark ignitor

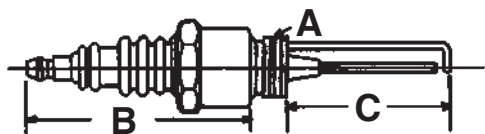

Dimensions in mm unless stated otherwise		
A	B	C
14 mm thread	51	38

## Flame rod

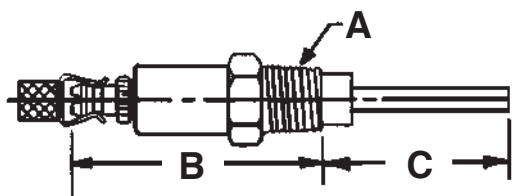

Dimensions in mm unless stated otherwise		
A	B	C
1/4" thread	51	181

## Adjustable orifice

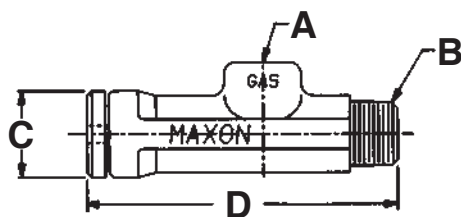

Dimensions in mm unless stated otherwise			
A	B	C	D
1/4" NPT	1/4" NPT	23	81

## Fixed orifice

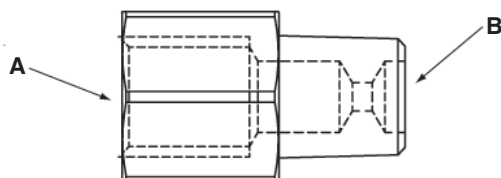

Dimensions in mm unless stated otherwise	
A	B
1/4" NPT	1/4" NPT

## Profile plate mounting bracket

On certain high temperature rise applications of AIRFLO<sup>®</sup> line burners, it is advantageous to partially close off the square or rectangular openings within the burner assembly in addition to installing the profile plate around the outside of the burner in order to increase the velocity sufficiently.

The stainless steel profile mounting plate bracket, illustrated in the sketches below, is used to support plates for this purpose. The plate used to close off a portion of the openings will need to be sized for each individual application and therefore will be fabricated and installed by the customer.

- 1) diam. = 1/4"
- 2) profile plate mounting bracket
- 3) profile plate

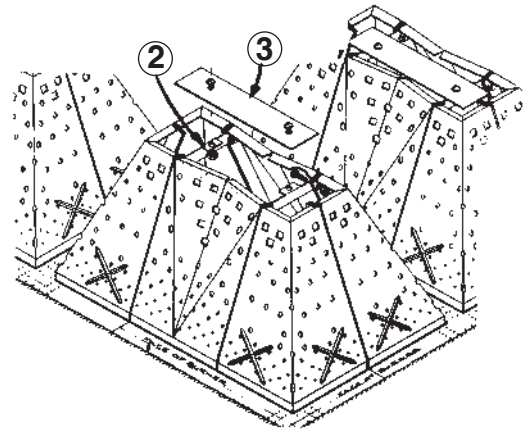
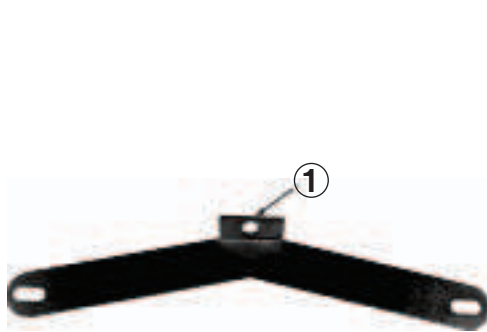

## Division plate

Division plates are used to isolate burner fuel manifolds. This way a burner can be split in two or more sections which can be controlled individually. This is frequently done in installations where extremely high turndown rates are required.

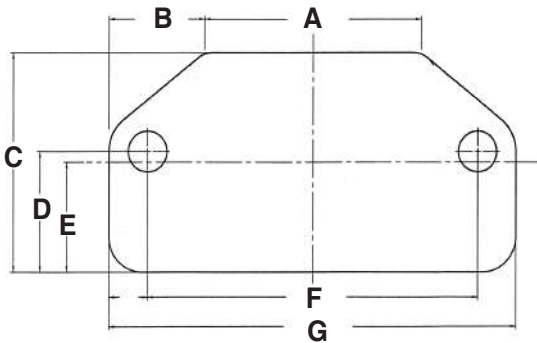

Dimensions in mm unless stated otherwise						
A	B	C	D	E	F	G
64	28	61	33	30	97	117



## Universal support brackets (USB)

Use these brackets to support the burner inside the process air duct.

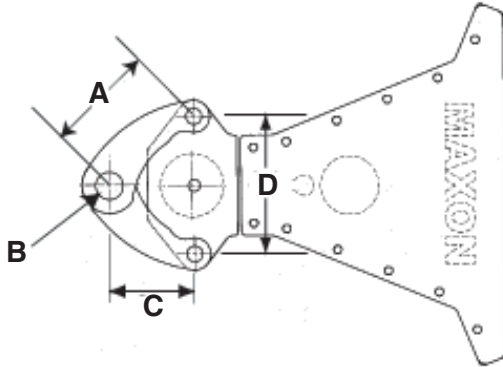

Dimensions in mm unless stated otherwise			
A	B	C	D
76	3/4" hole	64	97

## External mounting assembly

Frequently used to provide easy accessibility to spark ignitor and flame supervision components.

- 1) Includes mounting plate with 2 feed-through insulators for internal mounting of spark ignitor and flame rod
- 2) external mounting plate
- 3) used with typical pilot  
x) spark ignitor  
y) flame rod
- 4) opening required

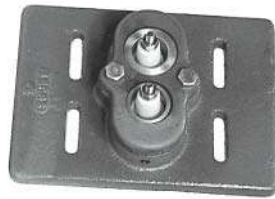

1

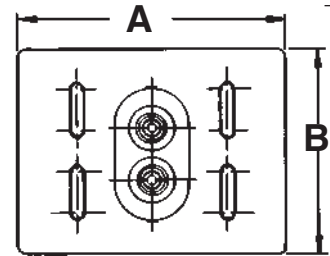

2

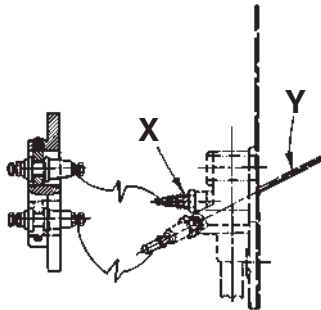

3

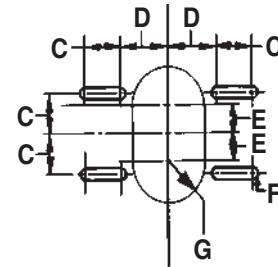

4

Dimensions in mm unless stated otherwise						
A	B	C	D	E	F Ø	G Ø
165	122	25	33	18	4	25

## End plate heaters

These heaters can be used in those applications where moisture on flame rods or spark ignitors can be expected. The heaters will keep the burner end plate and UV scanner tubes warmed and above dew point temperature when the burner is not firing.

Two versions are available. Depending on local standards, select either the CE-type or the CSA/UL-type.

Both versions have a 1/4" threaded connection which will fit directly on one of the flame rod connections on the burner end plate.

Type	CSA/UL	CE-230	CE-115
Voltage	120V/60Hz	230V/50Hz	115V/50Hz
Power (watt)	90	85	85
Material	Brass	Stainless steel	Stainless steel

- 1) Heating element 1/4" ISO
- 2) 17 mm wrench
- 3) Power cable

CE-type heater

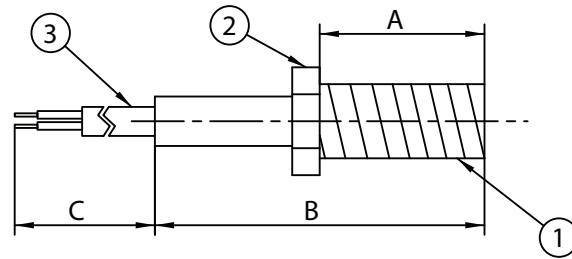

**Dimensions in mm unless stated otherwise**

A	B	C
30	60	1000

- 1) Heating element 1/4" NPT
- 2) Knurled end
- 3) SS braid shield power cable

CSA/UL-type heater

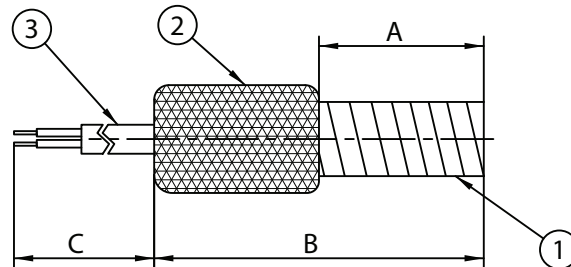

**Dimensions in mm unless stated otherwise**

A	B	C
32	61	1830

# INSTALLATION AND OPERATING INSTRUCTIONS

## Application requirements

### View port

A view port to observe burner flame is essential to inspect flame aspect. It is recommended to locate the view port downstream of the flame, such that the entire burner front can be observed, as well as the pilot burner.

### Position of the burner in the process flow

Series NP-LE AIRFLO<sup>®</sup> burners are used only for heating of fresh air in motion. They should be mounted so as to direct their flames parallel to and in the same direction as the movement of the air (see sketch below).

- 1) Profile plate
- 2) Burner front
- 3) Support
- 4) Burner mounting bracket

X = 35 mm

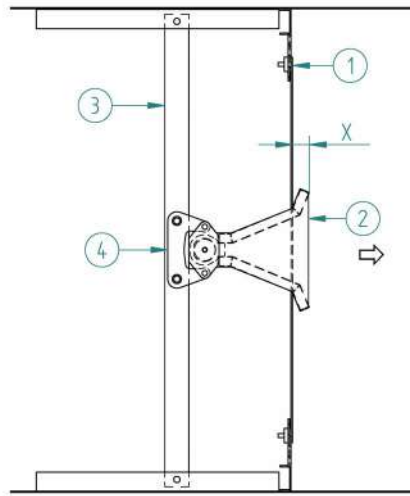

## CAUTION

Do not mount the burner so that the movement of air is across the face of the line burner, nor should it be mounted too near to a turn in the duct which may cause air to be directed at an angle over the burner. Velocity and flow of air at operating temperature must be uniform and not less than specified for the application.

# INSTALLATION INSTRUCTIONS

## Storage

Series NP-LE AIRFLO® burners should be stored dry (inside).

Do not discard packing material until all loose items are accounted for.

## Handling

Series NP-LE AIRFLO® burners may be shipped as complete burners, as well as in different burner parts.

Handle burners with care during transport, unpacking, lifting and installation.

Avoid bending or damaging the stainless steel mixing plates.

Use proper equipment. Any impact on the burner could result in damage. Contact MAXON in case of questions.

## Assembly instructions for burners divided into sections

Generally, the burners will be supplied as complete pre-assembled units. In some cases, however, the burner may be shipped as sub-assemblies, single sections may be supplied loose for shipping convenience (access of burner into the duct), or extra units of burner have been purchased to increase/modify the capacity/shape of the existing burner or as replacement items, etc.

Follow the assembly instructions below. In case of doubt, please contact MAXON for assistance.

Before being reassembled, the burner should be brought to the point of use. There, the burner should be arranged on the floor, mixing plates down, in the intended form. Reassemble as follows.

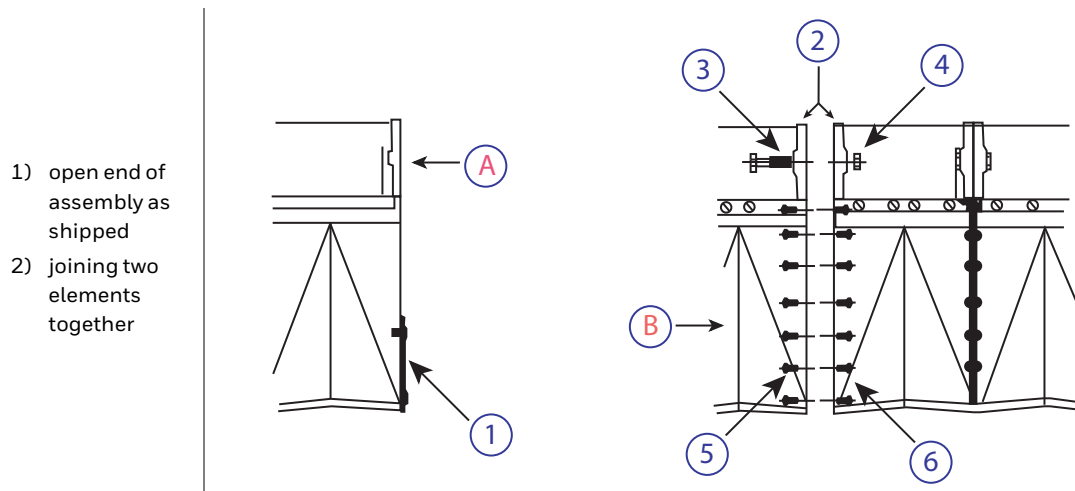

- Check the supply of gaskets, bolts and nuts attached to the crate.
- Remove the protective shipping end plates (1)
- Add support brackets, if any.
- Bring ends of burner sections together, insert gaskets and bolts, and loosely assemble nuts (4) to bolts (3) (2x).
- Insert and assemble bolts (5) and nuts (6) snug but not tight.

- Tighten burner bolts (3), but ensure burner sections do not slip.
- Recommended torque bolt and nuts:  $3/8 - 16 \times 1-1/2 = 55 \text{ Nm}$
- Tighten screws (4), keeping mixing plate gaskets properly aligned.
- Examine all joints to ensure that sealing is complete.

## Supporting the burner

Series NP-LE AIRFLO® burner assemblies must be adequately supported and positioned. Avoid rigid mounting. Burner assembly expands and contracts with temperature variations.

Maintain smooth, even air flow over the burner by designing supports to provide minimum interference, deflection and turbulence.

The sketches below show typical installation and support methods.

- 1) strap iron frame
- 2) MAXON support bracket
- 3) air movement
- 4) bolt or rod (long enough to permit brackets to move)
- 5) allow space for burner expansion
- 6) angle iron support
- 7) strap iron frame
- 8) strap iron to top of duct
- 9) gas inlet
- 10) strap iron brace to side of duct
- 11) gas manifold independently supported
- 12) strap iron to top of duct
- 13) ends free to move
- 14) strap iron to bottom of duct
- 15) oversize U-bolt drawn up loosely
- 16) angle iron support
- 17) rod
- 18) turn-buckle
- 19) support brackets
- 20) 3/4" hole
- 21) strap iron frame
- 22) bolt or rod (long enough to permit brackets to move)
- 23) support brackets

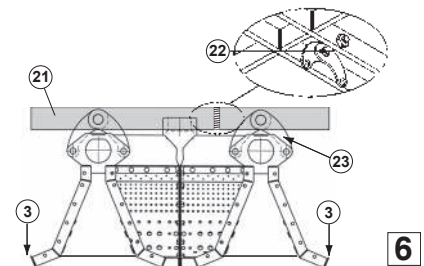
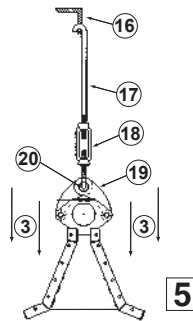
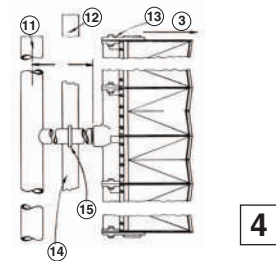
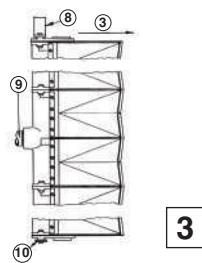
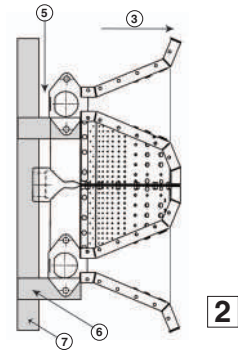
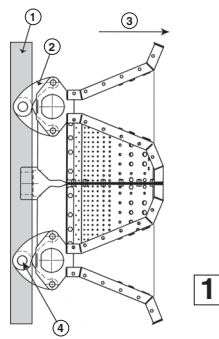

**Sketch 1** shows the burner suspended from a strap iron frame using MAXON USB support brackets. Note that rigid mounting is avoided by the bracket hole which slips loosely over a bolt or steel rod attached to the support. Gas piping would need independent support.

**Sketch 2** shows the burner assembly resting upon angle iron brackets and not attached to them in any way. Be sure the angle iron supports allow the burner flanges to expand and contract. Gas manifolding would be independently supported and prevent forward movement of the burner.

**Sketch 3** shows simple strap iron used to support the burner. Note that narrow edge of strap faces air flow to avoid undue turbulence.

**Sketch 4** shows gas manifolding used to support the burner. If there are multiple inlets, you must avoid rigid connection by using the oversize U-bolt (loosely drawn up) illustrated. Support for down-fired burners can be accomplished as shown in the illustration above. Always avoid rigid mounting.

**Sketch 5** shows MAXON USB support brackets suspending the burner from an overhead angle iron.

**Sketch 6** shows an alternate arrangement which offers the advantage of more controlled positioning.

# START-UP INSTRUCTIONS

Instructions provided by the company or individual responsible for the manufacture and/or overall installation of a complete system incorporating MAXON burners take precedence over the installation and operating instructions provided by MAXON. If any of the instructions provided by MAXON are in conflict with local codes or regulations, please contact MAXON before initial start-up of equipment.

## CAUTION

Read the combustion system manual carefully before initiating the start-up and adjustment procedure. Verify that all of the equipment associated with and necessary to the safe operation of the burner system has been installed correctly, that all pre-commissioning checks have been carried out successfully and that all safety related aspects of the installation are properly addressed.

Initial adjustment and light-off should be undertaken only by a trained commissioning engineer.

## First firing or restart after shut-down

Before start-up, or after a longer period shut-down, integrity of the system should be checked by an authorized combustion engineer. Besides the general mechanical installation of burner and piping (rigidity, flanged and threaded connections, tightness of piping and burner body, etc.), it is advised to check the condition of mixing plates and burner body drillings.

Check all bolted connections of the burner after first firing (first time on temperature) and retighten if necessary.

## Check of safety interlocks

## CAUTION

Guarantee that all the required safety locks as described in the applicable local codes or regulations, or extra requested for safe operation of the overall installation are working properly and resulting in a positive safety lock of the burner. Do not bypass any of these safety interlocks. This will result in unsafe conditions.

## Process air flow

Series NP-LE AIRFLO<sup>®</sup> burners are raw gas burners. This means that the required oxygen for combustion is drawn from the available process air flow across the burner.

A correct fresh air flow across the burner is essential for safe operation of the burner and should be safeguarded by a safety-interlock (pressure switch or flow switch) as described in the applicable local codes or regulations.

Refer to “Specifications” on page 4-21.6-7 for more details or contact MAXON if you require further support.

## Pilot ignition

Adjust pilot gas regulator to correct set point before pilot ignition attempt. Refine during lighting of the pilot to a hard, blue flame and/or strongest stable flame signal.

## Main burner ignition

Adjust the main gas regulator at the correct set-point before igniting the main burner. Ensure that the control valve is in the start position when lighting the main burner.

Note that operating characteristics of some regulators may require additional adjustment while firing the burner. Ensure operating pressure to the burner under operating conditions matches those shown on page 4-21.6-7.

## Minimum capacity and cross-ignition

Adjust the minimum burner capacity while carefully observing the flame. Ensure that the flame remains stable over the entire burner front.

The minimum capacity of the burner may be influenced by the process air distribution across the burner, the air stream velocity and the position (distribution) and number of gas inlets of the burner.

If the burner is ignited at minimum capacity, verify (by several repeats) that the flame is smoothly cross-igniting over the entire burner front.

## Ratio adjustment

Slightly open the gas control valve while observing the flame. Especially observe that the flame is well divided over the entire burner surface and going straight forward in the direction of the process air flow. Check that no damage is caused to duct walls, filters, blowers, etc.

Limit the minimum and maximum position in a safe way to guarantee stable flame over the entire burner front at minimum position and to protect the burner for overfiring at maximum position.

## Flame supervision

Only use the standard connections provided on the end plates for correct flame safeguarding. Use proper flame detection equipment (flame rod or UV scanner).

Refer to the local codes and regulations to determine the number of flame sensors and their position. Be advised that some codes may require proving of cross-ignition by sensing flame on both ends of long burners.

# MAINTENANCE INSTRUCTIONS

Periodic maintenance will insure continued trouble-free operation of your Series NP-LE AIRFLO<sup>®</sup> burner system.

At least a yearly inspection is recommended for make-up air heating installations and more frequently for process applications in year-round operation. Your own experience is the best guide in determining frequency of inspection. As a minimum, the following procedure should be followed:

- Shut the system down totally. Disconnect or lock out power supply so there can be no accidental start-up during inspection.
- Inspect the burners carefully, including upstream and downstream sides of mixing plates as well as burner body face. Any accumulation of scale or foreign material on either side of the mixing plates should be removed with a wire brush. Check visually that no holes in the mixing plates are blocked. See page 4-21.6-35 for inspection and maintenance instructions for gas ports.



## **WARNING**

**Do not enlarge burner ports or performance may be drastically affected.**

- If any mixing plates are loose or missing fasteners, tighten/replace as necessary. Always use zinc plated or stainless metric fasteners.
- Put system back into operation and, if possible, view from downstream side while cycling burner through full firing range. This will give a visual check for blocked burner ports.
- Observe flame pattern and, if necessary, take steps to correct velocity and/or air distribution problems.

### **Repair/replacement procedures**

If adverse operating conditions or accidental damage make it necessary to replace either individual mixing plates or complete burner sections, follow this procedure:

- Identify necessary replacement parts from component identification drawings on the following pages, then order required quantities of each. Consider carefully the economics of installing a complete replacement burner instead of replacing individual parts. Once exposed to actual flame temperatures, burner castings harden and the removal and replacing of fasteners can

be time consuming and difficult. Accessibility may also be severely limited requiring removal of complete assembly in any case.

- When necessary parts have been received, remove damaged mixing plates or burner sections, taking care not to damage remaining portion of burner. If new burner bodies are being installed, place body gasket on the mating flanges of loose cast iron bodies. (This is necessary to provide a gas-tight seal after assembly.) Insert new section into place, making sure that both flanges are square and flush, then bolt sections together.
- Install new mixing plates, back up bars and plate support brackets to the new body castings.
- If end plate sets must be installed, put in position between mixing plates and insert fasteners loosely. Do not tighten at this time.
- Tighten burner body bolts making sure that mating cast iron flanges remain square and flush.
- Align mixing plates and check that body gaskets are in position and properly aligned. Tighten all mixing plate mounting screws and bolts.
- Double check that all fasteners are secure.
- Return burner to operation, observing flame carefully at all firing rates.

### **Inspection and maintenance of gas ports**

- Conduct initial inspection within the first month after commissioning. Visually check the gas ports of new burner assemblies for any piping scale or debris. Use pin vise with drill bit to remove.
- Annual inspections are normally adequate once the initial piping debris is removed. The operating conditions of the burner will determine how frequently maintenance is actually required.
- Use of an electric drill motor is not suggested unless both pin vise and drill (as shown below) can be chucked up in a vari-speed drill unit. Use caution, because it is easy to snap the bits off in a port when using a drill motor. Removal of broken bits from the gas ports is difficult.
- Contact your MAXON representative to answer questions or address any problems.

## NP1-LE & NP2-LE AIRFLO® burner gas ports

- 1) Pin vise
- 2) 25 mm
- 3) NP-LE AIRFLO® burner body (mixing plates not shown)
- 4) Gas ports - all are #43 drill size (exception is several #47 holes at the intersection of 12x6 tee's and 36 BI's)
- 5) #47 holes here
- 6) #43 holes

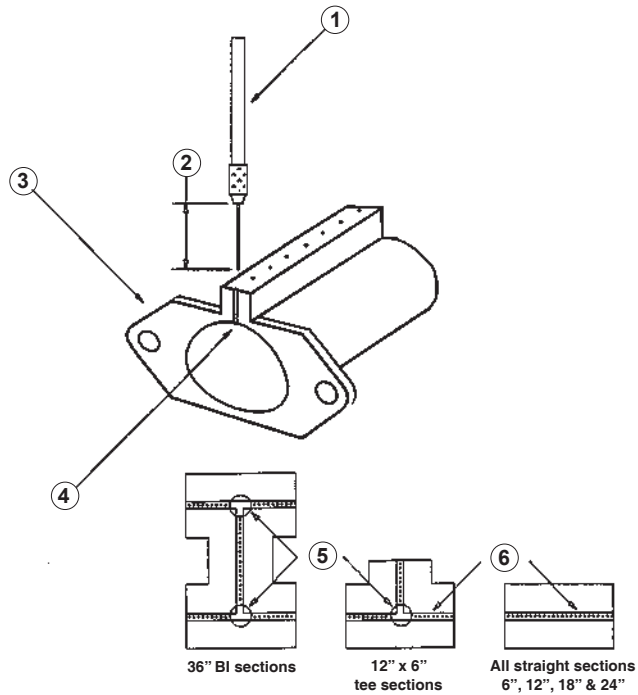

## NP2-LE AL AIRFLO® gas ports

- 1) NP2-LE AL AIRFLO® burner body (mixing plates not shown)
- 2) Outside rows - #47 holes
- 3) Inside row - #43 holes

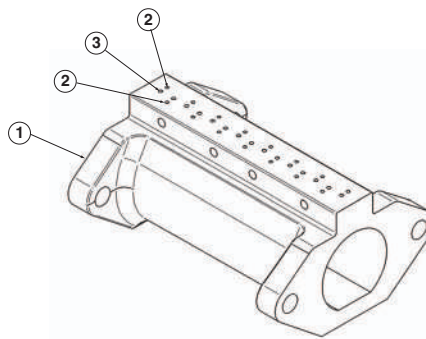



# MAINTENANCE AND COMPONENT IDENTIFICATION

## NP1-LE AIRFLO® burners

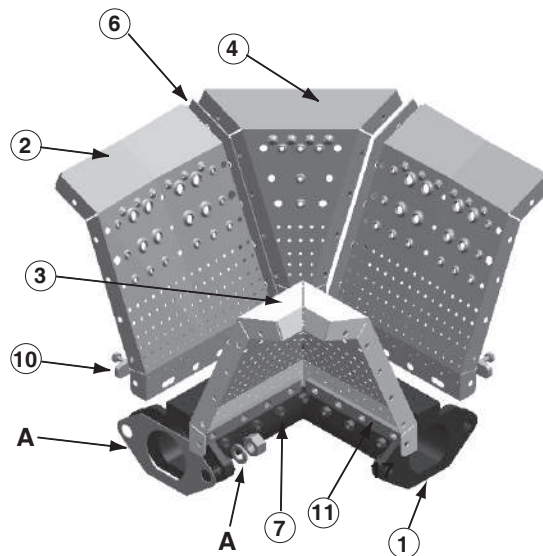
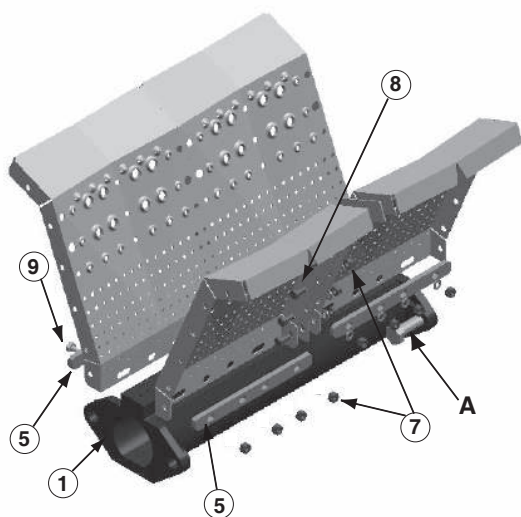

To order replacement parts:

- See burner nameplate and indicate burner type.
- Sketch burner arrangement (as viewed from casting side).
- Specify replacement items required from diagrams above.
- Specify quantity of each from table below:

Item No.	Part description	Quantity required for indicated section							
		6" str.	12" str.	18" str.	24" str.	12" x 6" tee	6" x 6" elbow	12" BI	36" BI
1	Burner body								
2	Mixing plate	2	4	6	8	2	2	4	4
3	Mixing plate: inside corner					2	1		4
4	Mixing plate: wedge						1		
5	Back up bar	2	4	6	8			4	
6	Gasket/shim (metal)	2	2	2	4	1	2	2	4
7	M5 K-nut plated	4	20	24	48	18	20	20	48
8	M5 x 10 ISO 4017 plated hex bolt		12	12	24	6	12	12	24
9	M5 x 45 ISO 4017 plated hex bolt	4	8	12	16	12	8	8	24
10	Outside corner back up bar					2	2		4
11	Inside corner back up bar					4	2		8

NOTE: These items included with fastener kits. See page 38 for fastener kit details.

## NP1-LE-AL AIRFLO® burners

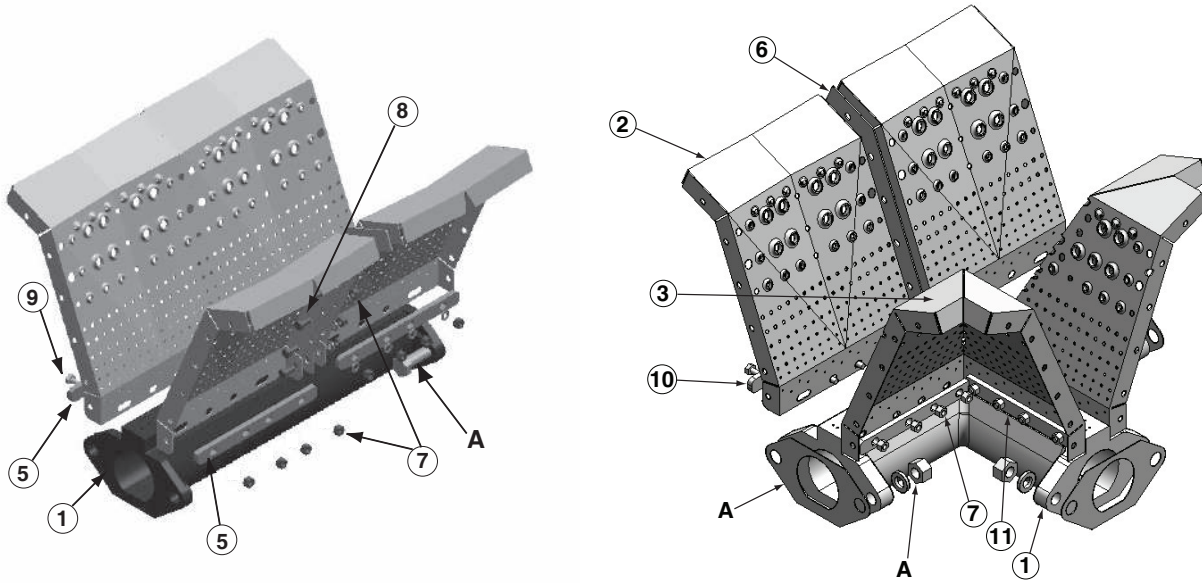

To order replacement parts:

- See burner nameplate and indicate burner type.
- Sketch burner arrangement (as viewed from casting side).
- Specify replacement items required from diagrams above.
- Specify quantity of each from table below:

Item No.	Part description	Quantity required for indicated section						
		6" str.	12" str.	18" str.	24" str.	12" x 6" tee	12" BI	36" BI
1	Burner body							
2	Mixing plate	2	4	6	8	2	4	4
3	Mixing plate: inside corner					2		4
4	Mixing plate: wedge							
5	Back up bar	2	4	6	8		4	
6	Gasket/shim (metal)	2	2	2	4	1	2	4
7	M5 K-nut plated	4	20	24	48	18	20	48
8	M5 x 10 ISO 4017 plated hex bolt		12	12	24	6	12	24
9	M5 x 45 ISO 4017 plated hex bolt	4	8	12	16	12	8	24
10	Outside corner back up bar					2		4
11	Inside corner back up bar					4		8

NOTE: These items included with fastener kits. See page 38 for fastener kit details.

# NP1-LE-AL-SS AIRFLO® burners

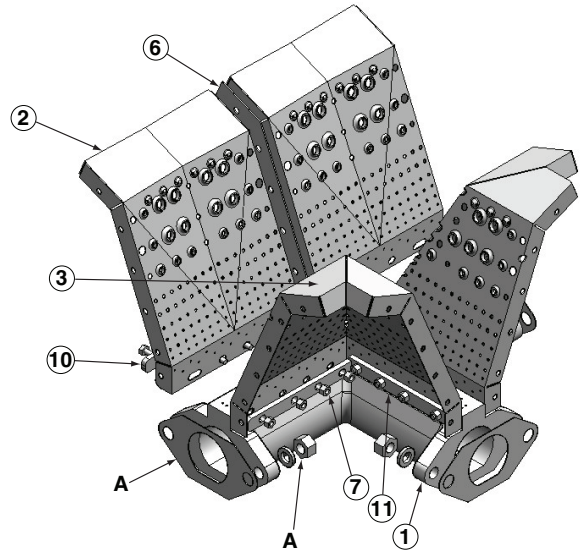
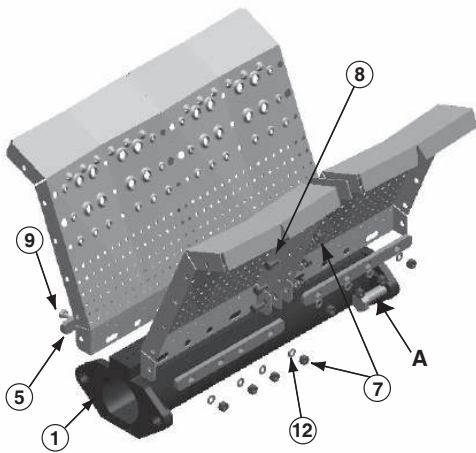

To order replacement parts:

- See burner nameplate and indicate burner type.
- Sketch burner arrangement (as viewed from casting side)
- Specify replacement items required from diagrams above.
- Specify quantity of each from table below:

Item no.	Part description	Quantity required for indicated section						
		6" str.	12" str.	18" str.	24" str.	12" x 6" tee	12" BI	36" BI
1	Burner body							
2	Mixing plate	2	4	6	8	2	4	4
3	Mixing plate: inside corner					2		4
4	Mixing plate: wedge							
5	Back up bar (aluminum)	2	4	6	8		4	
6	Gasket/shim (metal)	2	2	2	4	1	2	4
7	M5 nut stainless steel	4	20	24	48	18	20	48
8	M5 x 10 ISO 4017 hex head screw (stainless steel)							
9	M5 x 45 hex head screw class A (stainless steel)	4	8	12	16	12	8	24
10	Outside corner back up bar (aluminum)					2		4
11	Inside corner back up bar (aluminum)					4		8
12	M5 stainless steel lockwasher	4	20	24	48	18	20	48

NOTE: These items included with fastener kits. See page 38 for fastener kit details.

## NP2-LE AIRFLO® burners

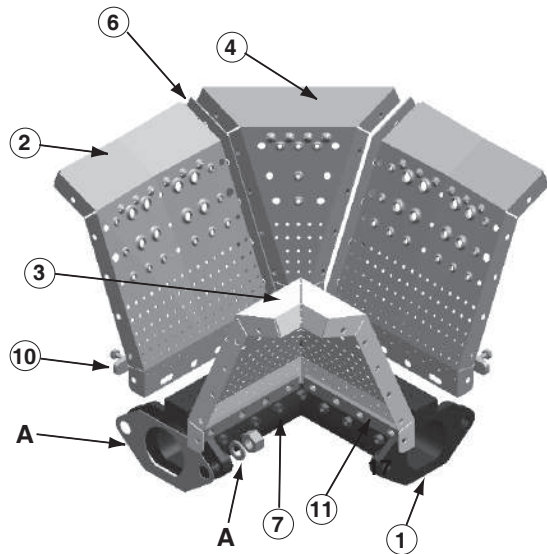
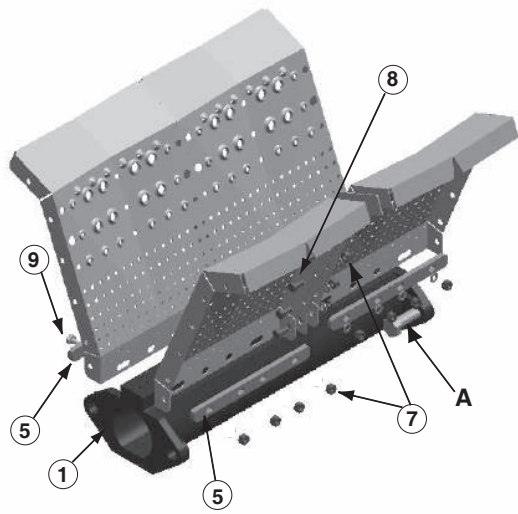

To order replacement parts:

- See burner nameplate and indicate burner type.
- Sketch burner arrangement (as viewed from casting side)
- Specify replacement items required from diagrams above.
- Specify quantity of each from table below:

Item no.	Part description	Quantity required for indicated section							
		6" str.	12" str.	18" str.	24" str.	12" x 6" tee	6" x 6" elbow	12" BI	36" BI
1	Burner body								
2	Mixing plate	2	4	6	8	2	2	4	4
3	Mixing plate: inside corner					2	1		4
4	Mixing plate: wedge						1		
5	Back up bar	2	4	6	8			4	
6	Gasket/shim (metal)	2	2	2	4	1	2	2	4
7	M5 K-nut plated	4	20	24	40	18	20	20	48
8	M5 x 10 ISO 4017 plated hex bolt		12	12	24	6	12	12	24
9	M5 x 45 ISO 4017 plated hex bolt	4	8	12	16	12	8	8	24
10	Outside corner back up bar					2	2		4
11	Inside corner back up bar					4	2		8

NOTE: These items included with fastener kits. See page 38 for fastener kit details.

## NP2-LE-AL AIRFLO® burners

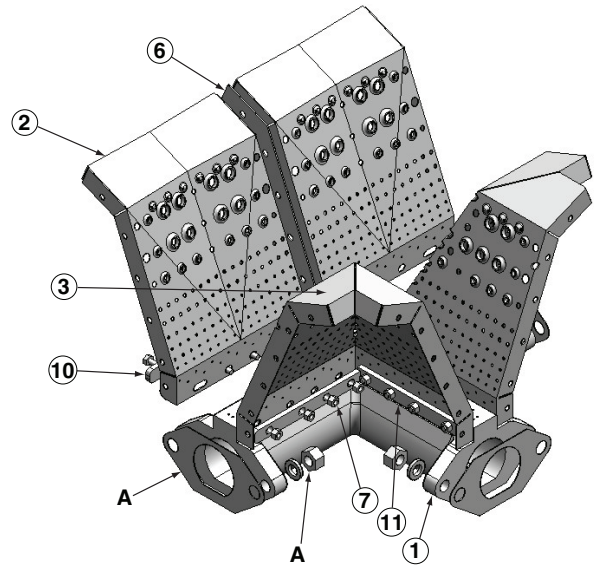
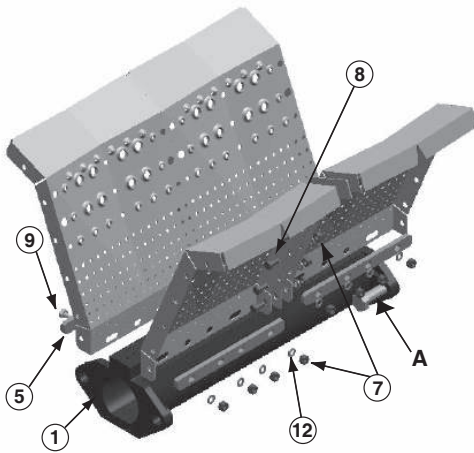

To order replacement parts:

- See burner nameplate and indicate burner type.
- Sketch burner arrangement (as viewed from casting side)
- Specify replacement items required from diagrams above.
- Specify quantity of each from table below:

Item no.	Part description	Quantity required for indicated section			
		6" str.	12" str.	12" x 6" tee	12" BI
1	Burner body				
2	Mixing plate	2	4	2	4
3	Mixing plate: inside corner			2	
4	Mixing plate: wedge				
5	Back up bar	2	4		4
6	Gasket/shim (metal)	2	2	1	2
7	M5 K-nut plated	4	20	18	20
8	M5 x 10 ISO 4017 plated hex bolt		12	6	12
9	M5 x 45 ISO 4017 plated hex bolt	4	8	12	8
10	Outside corner back up bar			2	
11	Inside corner back up bar			4	

NOTE: These items included with fastener kits. See page 38 for fastener kit details.

## Fastener kits

### End plate fastener kit

- 1) M5 x 20 hex head screw
- 2) Body gasket
- 3) M10 lock washer
- 4) M10 x 1.5 hex nut
- 5) M5 K-nut
- 6) M5 lock washer (SS only)
- 7) Shim gasket
- 8) End plate gasket

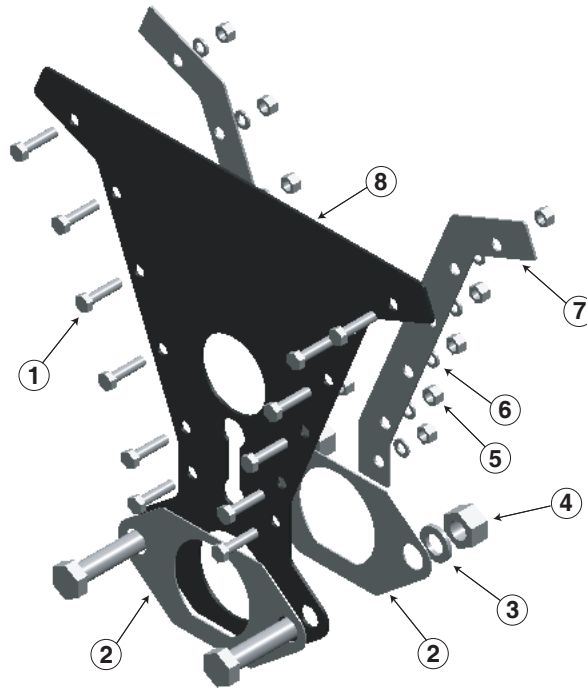

### Body to body fastener kit

- 1) M5 x 10 hex head screw
- 2) M10 x 50 hex head screw
- 3) Body gasket
- 4) M10 lock washer
- 5) M10 x 1.5 hex nut
- 6) M5 lock washer (SS only)
- 7) M5 nut
- 8) Shim gasket

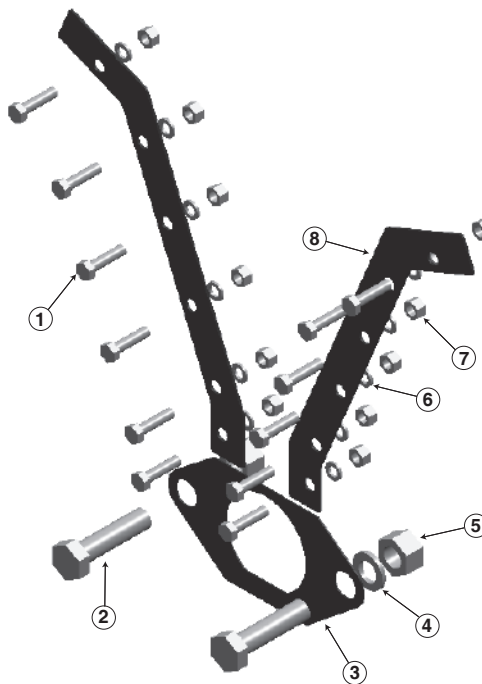



### **For More Information**

The Honeywell Thermal Solutions family of products includes Honeywell Combustion Safety, Eclipse, Exothermics, Hauck, Kromschröder and Maxon. To learn more about our products, visit [ThermalSolutions.honeywell.com](http://ThermalSolutions.honeywell.com) or contact your Honeywell Sales Engineer.

### **Honeywell MAXON branded products**

201 E 18th Street  
Muncie, IN 47302  
USA

[www.maxoncorp.com](http://www.maxoncorp.com)

### **Honeywell Process Solutions**

Honeywell Thermal Solutions (HTS)  
1250 West Sam Houston Parkway  
South Houston, TX 77042  
[ThermalSolutions.honeywell](http://ThermalSolutions.honeywell)

® U.S. Registered Trademark  
© 2018 Honeywell International Inc.  
32M-03006-02 M.S. Rev. 07-18  
Printed in United States

