

Design Features and Operating Concepts

Valves with electro-mechanical actuators for quick opening or closing action

Normally closed shut-off valves are used in burner system fuel supply lines on industrial boilers, furnaces, ovens, kilns, and other heating processes. All valves are designed to shut-off fuel automatically and instantly with an interruption in the electric power supplied through your safety circuit.

These valves are also used for the **manual** or **motorized** opening or closing of pipe lines carrying gases and liquids commonly used in industrial processes. Normally closed valves cannot be opened until the interlocking safety control circuit is proven and resulting electrical power is supplied to the shut-off valve.

Motorized automatic valve actuators are used where remote access or unmanned applications are needed.

NOTE: Valve motors and solenoids are protected against thermal overload. If the valve duty cycle is exceeded, the motor and/or solenoid must be allowed to cool before the internal thermal protection will automatically reset.

Manual reset actuators require operating personnel to be physically present to actuate the valve from its at rest position.

Normally open vent valves are most often used as the bleed valve in a block-and-bleed pipe train, sometimes required by insurance authorities. They are designed to open a vent line automatically and instantly upon an interruption in the electric power supply through your safety control circuit.

These normally open valves are also used in protective atmosphere systems and other gaseous and fluid service requiring quick opening or by-pass purging action.

Like the normally closed versions, both automatic and manual reset actuators are available for remote access locations, or when operating personnel's physical presence is preferred.

All Maxon valves feature one-piece cast iron or cast steel bodies with micro-lapped seats and discs. Straight-through flow path minimizes pressure drop through full open swinging gate or rising stem (guillotine action) bodies.

Valve Body Design Details

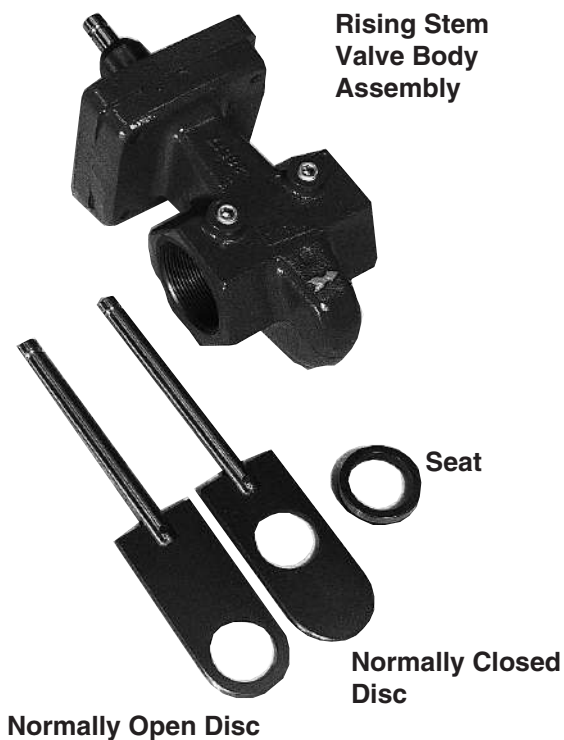

To provide fuel shut-off in your process service lines, Maxon uses two different styles of valve bodies:

Rising stem (guillotine action) bodies are frequently used in normally closed and normally open gas valves. The micro-lapped, spring loaded guillotine disc gets a pressure assist from the flowing gases to seal against the downstream micro-lapped metal seat ring. The carefully machined seal surfaces and extremely close tolerances of the valve body operating mechanism promote positive closing action. Frequent cycling action constantly shears accumulated dirt or residue from the disc and seat to insure instantaneous and reliable sealing.

The location of the port in the disc is the basic difference between normally open and normally closed valve bodies. Both valves function by the top assembly mechanism driving the stem and disc down into the valve body, opening (or closing) the flow path. Both valves trip to their rest position when their top assembly's compression spring is released to pull the stem and connected disc up out of the body.



Swinging gate bodies are frequently used as normally closed oil valves and for some special service gas applications. This design provides the same seal capabilities, but in a slightly different operating mode. The hard faced micro-lapped seat nut is threaded into the one-piece valve body. The free-floating, hard faced, spring loaded circular disc swings across the seat. Line pressure also assists in sealing the disc to the downstream seat.

Here again, frequent use and cycles actually helps to keep your valve clean. Since the free-floating disc is swinging across the circular seat nut on the arc created by the disc carrier, the disc rotates slightly on every cycle. This provides a fresh, clean surface area for sealing off the flow lines.

Maxon valve bodies have special service trim options available to meet your particular fluid service requirements.

Valve Body Capacities/Specifications

Table 1: Normally closed valve bodies

Body Material	End Connections	Pipe Size in inches	C _v Factor	Body Type [1]
Gray Iron	Threaded	.75	20	RS
		1	12	SG
			20	RS
		1.25	17	SG
			45	RS
		1.5	53	RS
		2	86	RS
		2.5	127	RS
			304	RS
		3	173	RS
	423		RS	
	Flanged	2	86	RS
		2.5	127	RS
			304	RS
		3	423	RS
		4	490	RS
6		719	RS	
Cast Steel	Threaded	1	12	SG
			20	RS
		1.25	17	SG
			45	SG
		45	RS	
		1.5	53	RS
	2	86	RS	
	Flanged	2.5	304	RS
		3	423	RS
		4	490	RS
		6	719	RS

[1] RS = Rising stem body; SG = Swinging gate body

See catalog pages 6215-6217 for construction details

NOTE: Typically, pressure drop for gas flows should not exceed 10% of inlet pressure; however, for 2" and smaller valves, the drop should not exceed 5 PSIG, and for 2-1/2" and larger valves, must not exceed 2.5 PSIG. Select valve size on basis of the **lower** of these parameters to avoid critical flow conditions.

Table 2: Normally open valve bodies

Body Material	End Connections	Pipe Size in inches	C _v Factor	Body Type [1]
Gray Iron	Threaded	.75	20	RS
		1	20	RS
		1.5	53	RS
		2	86	RS
		2.5	304	RS
		3	423	RS
	Flanged	2	86	RS
		2.5	304	RS
		3	423	RS
		4	490	RS
Cast Steel	Threaded	1	20	RS
		1.5	53	RS
		2	86	RS
	Flanged	2.5	304	RS
		3	423	RS
		4	490	RS

Each complete valve assembly must include one of these valve bodies, regardless of ultimate series designation.

Flows through the valve body and resulting pressure drops may be estimated by inserting your specific conditions into the following formula and using C_v flow factors given for each valve body.

$$\text{Gases: } Q = (1360) \times (C_v) \times \left(\sqrt{\frac{(P_1 + P_2)}{G T_f}} \right) \times \left(\sqrt{\frac{(P_1 - P_2)}{2}} \right)$$

$$\text{Liquids: } V = (C_v) \times \left(\sqrt{\frac{(P_1 - P_2)}{G_f}} \right)$$

Where:

- G = Gas specific gravity (air = 1.0)
- G_f = Specific gravity @ flowing temperature °F
- P₁ = Inlet pressure PSIA (14.7 psi + psi gauge)
- P₂ = Outlet pressure PSIA (14.7 psi + psi gauge)
- Q = Cubic feet per hour @ 14.7 PSIA and 60°F
- T_f = Flowing temperature absolute (460° + °F)
- V = Flow in U.S. gallons/minute of water

Valve Body Capacities with Natural Gas at 5 inches w.c.

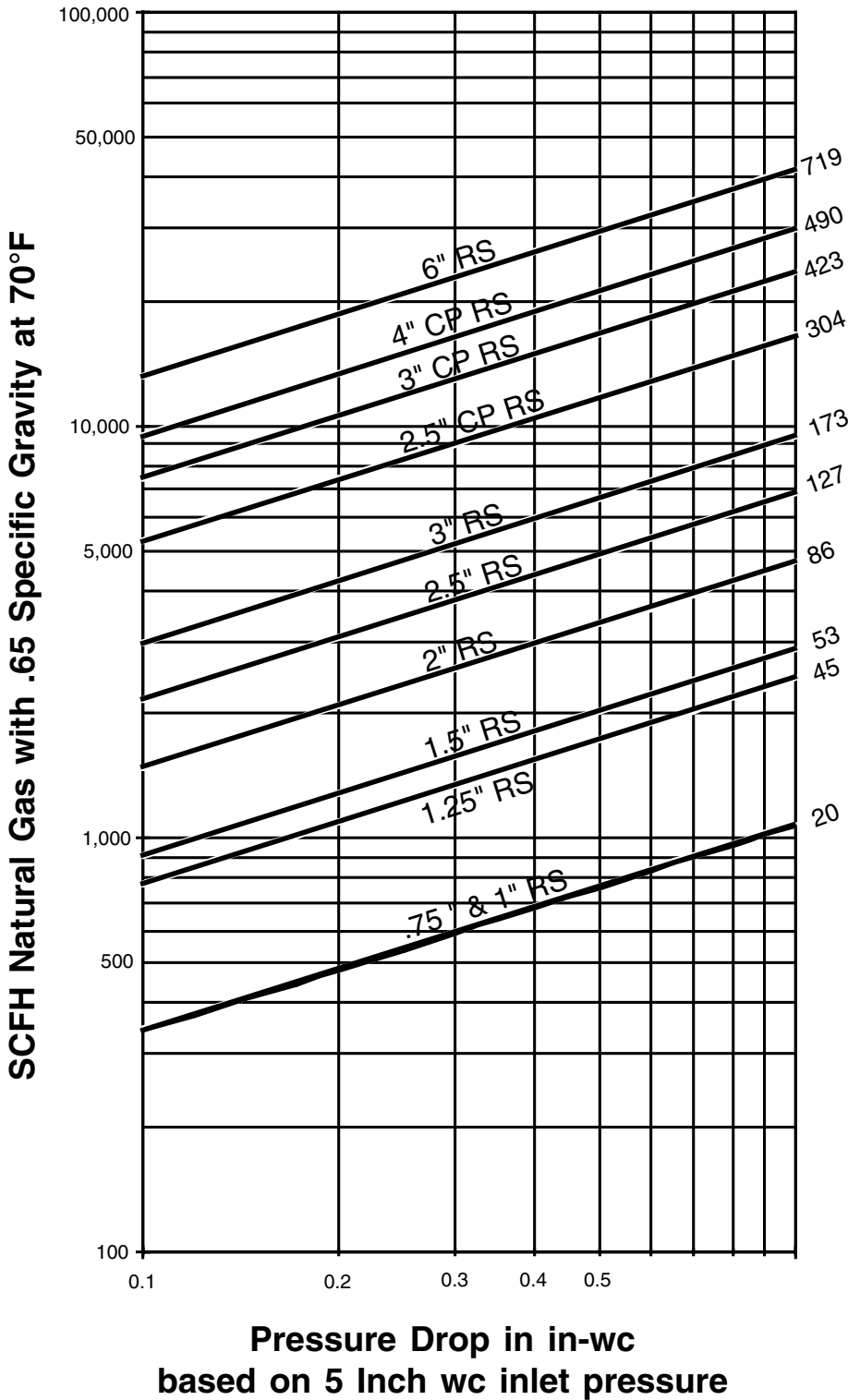

Approximate pressure drops for various valve sizes and flows may be determined by using this graph.

Typically, pressure drop for fuel flows should not exceed 10% of inlet pressure.

Select valve size on basis of these parameters to avoid critical flow conditions.

Valve Body Capacities with Natural Gas at 1 PSIG

Approximate pressure drops for various valve sizes and flows may be determined by using this graph.

Typically, pressure drop for fuel flows should not exceed 10% of inlet pressure.

Select valve size on basis of these parameters to avoid critical flow conditions.

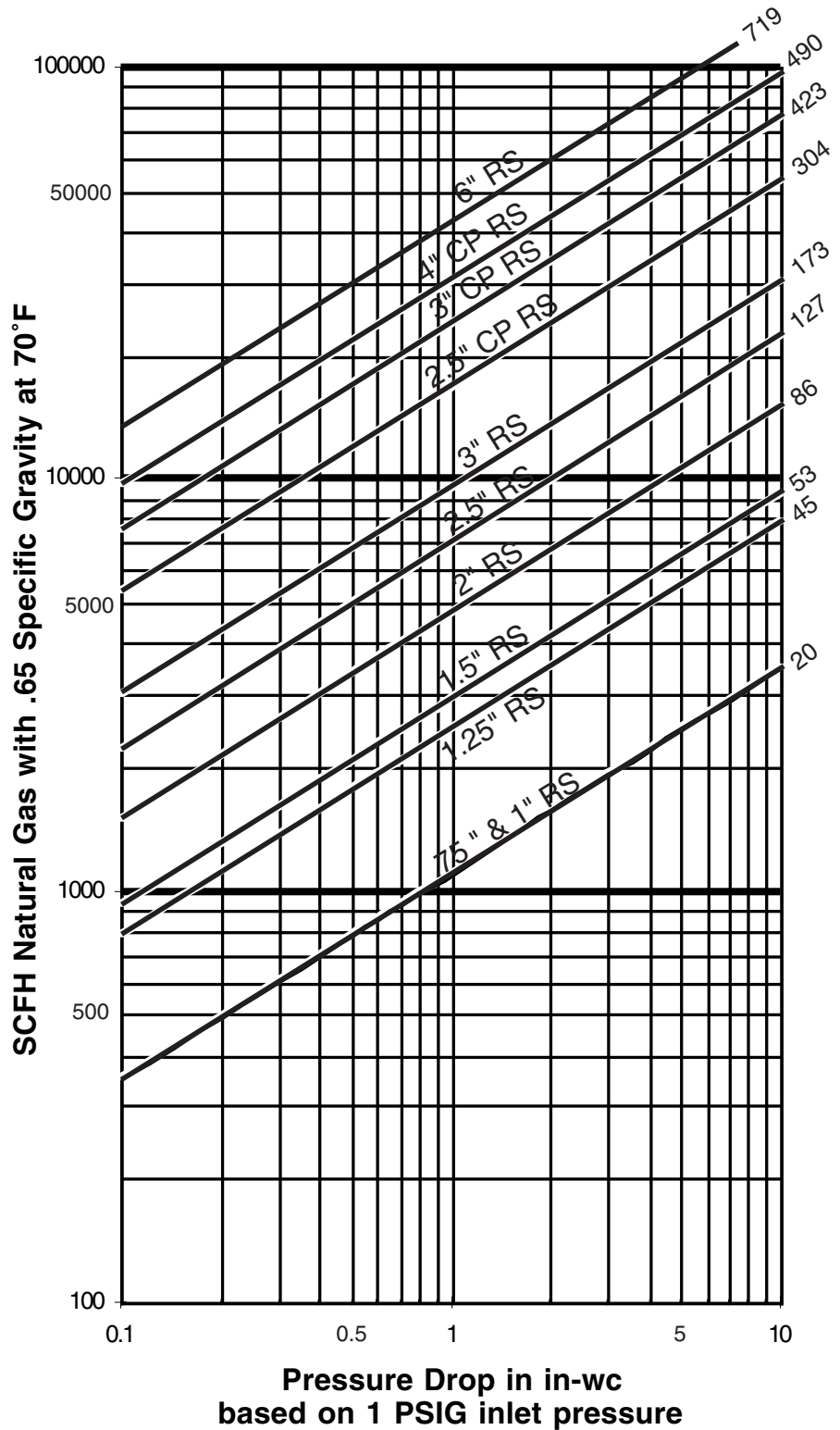

Valve Body Capacities with Natural Gas at 5 PSIG

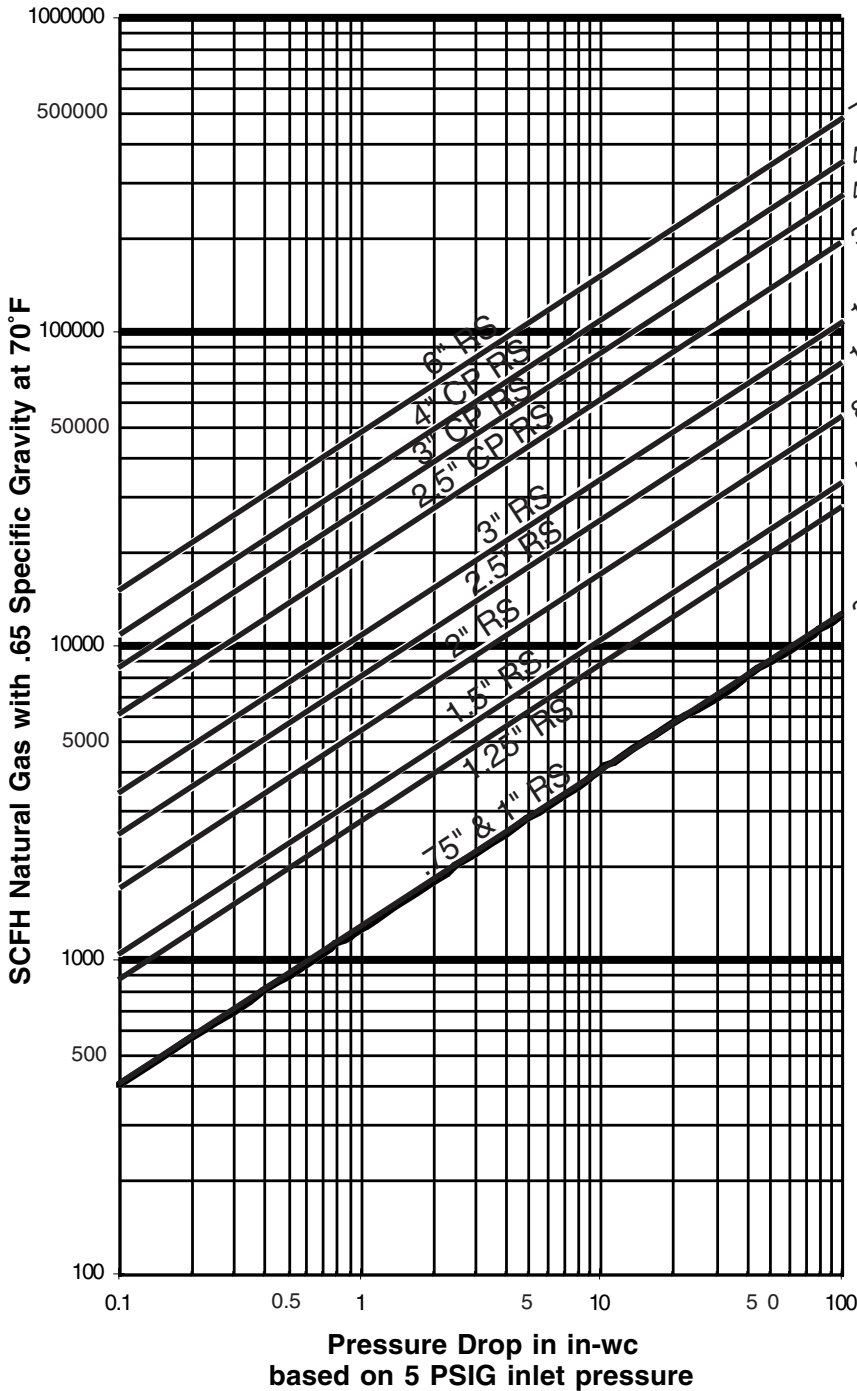

Approximate pressure drops for various valve sizes and flows may be determined by using this graph.

Typically, pressure drop for fuel flows should not exceed 10% of inlet pressure; however, for 2" and smaller valves, the drop should not exceed 5 PSIG, and for 2-1/2" and larger size valves, must not exceed 2.5 PSIG.

Select valve size on basis of the **lower** of these parameters to avoid critical flow conditions.

Valve Body Capacities with #2 Oil

To select a valve for **YOUR application**, use either C_v factor calculations, or this graph showing approximate pressure drop at various flows of #2 oil.

Typically, pressure drop for fuel flows should not exceed 10% of inlet pressure.

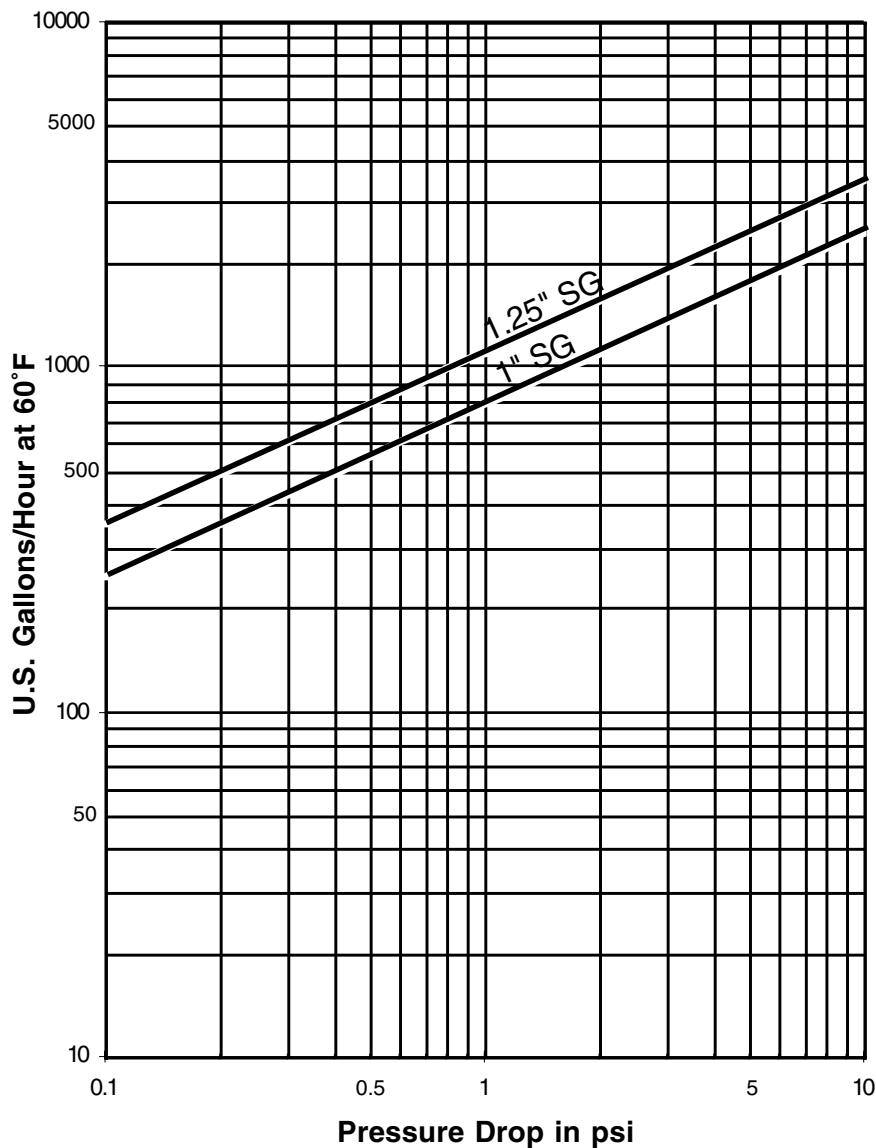

For preheated #5 or #6 oil, multiply the required flow rate in GPH by the factor given in the table at right, then select a valve based upon that equivalent flow of #2 oil and the allowable drop.

Oil Grade	#5		#6				
°F @ Inlet	125	160	120	140	180	210	220
Factor	1.43	1.11	2.86	2.00	1.25	1.11	1.05

For example: To size for 5 PSIG drop with a 3500 GPH flow of #6 oil preheated to 140°F, the multiplier is 2. Equivalent flow of #2 oil is then 3500 x 2, or 7000 GPH. Chart shows that a 5 PSIG drop will require use of a valve body having a C_v factor of at least 45.

Selection Data

Normally closed, swinging gate valves

Series Designation

Body Material>	Gray Iron	Cast Steel
Top Assembly Function	Sanctioned Service [1]	Sanctioned Service [1]
Manual Reset	730NI	760NI
Automatic Reset	4730NI	4760NI

[1] Sanctioned series are sold for fuel oils and carry FM sanctions. They are IRI approvable for #1 and #2 fuel oils, kerosene, JP-4 and preheated #4, #5 and #6 oils with maximum viscosity of 5000 SSU. Other gases and liquids may be sanctioned. Contact Maxon with your fuel analysis.

Temperature Limits

All of these valves can handle **fluid temperatures** from -20°F (-28°C) to +250°F (+121°C).

Ambient temperature limits vary. The valves on this page handle ambient temperatures from -20°F (-28°C) to +140°F (+60°C).

Operation

All electro-mechanical valves require a constant supply of electrical energy to their holding solenoids inside the top assembly actuators. Once the solenoid is energized, the 730NI and 760NI valves may be opened manually, or the 4730NI and 4760NI valves will automatically open. Any interruption of the electrical power to either of these valves causes an immediate trip of the valve to its normally closed position.

Features:

- Normally closed
- Electrically actuated
- Swinging gate body
- For shut-off service

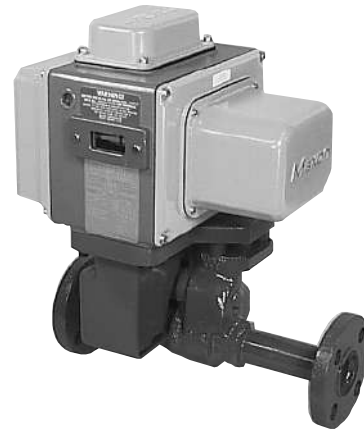

1.25" Series 4760NI

Available Sizes and Pressure Ratings

Pipe Size (inches)	Body C _v Flow Factor	Maximum Inlet Pressure (PSIG) [1]			
		Gray Iron Bodies		Cast Steel Bodies	
		Fuel Oils	Special Service	Fuel Oils	Special Service
1	12	300	265	600	265
1.25	17				
1.25 HC	45	---	---	300	265

[1] Maximum operating pressure differential (MOPD) in psi must not exceed maximum inlet pressure shown.

Selection Data

Normally closed, rising stem valves

Series Designation

Body Material >	Gray Iron	Cast Steel
Top Assembly Function	Sanctioned Service [1]	Sanctioned Service [1]
Manual Reset	808NI 808NI-CP	808NI-S 808NI-SCP
Automatic Reset	5000NI 5000NI-CP	5000NI-S 5000NI-SCP

[1] **Sanctioned series** carry FM sanctions for air, natural or liquified petroleum gases. They are normally approvable for clean fuel gases. Additionally, series with internal trim -2 are sanctioned for #1 and #2 fuel oils. Other gases and liquids may be sanctioned. Contact Maxon with your fuel analysis.

Features:

- Normally closed
- Electrically actuated
- Rising stem body
- For shut-off service

Temperature Limits

All these valves can handle **fluid temperatures** from -20°F (-28°C) to +140°F (+60°C). Oil viscosity not to exceed 5000 SSU. **Ambient temperature limits vary.** The valves on this page handle ambient temperatures from -20°F (-28°C) to +140°F (+60°C).

Operation

All of these electro-mechanical valves require a constant supply of electrical energy to their solenoid inside the top assembly actuators. Once that device is energized, the Series 808NI (-CP) valves may be manually opened, or the Series 5000NI (-CP) valves will automatically open. Any interruption of the electrical power to either of these valves causes an immediate trip of the valve to its normally closed position.



3" Series 808NI

Available Sizes and Pressure Ratings

Pipe Size (inches)	Body C _v Flow Factor	Maximum Inlet Pressure (psi) [1]			
		Gray Iron Bodies		Cast Steel Bodies	
		Clean Gases	Special Service	Clean Gases	Special Service
.75	20	125	65	---	---
1		125	65	125	65
1.25	45	100	65	---	---
1.5	53	70	65	70	65
2	86	70	65	70	65
		70	65	70	65
2.5	127	40	40	---	---
		40	40	---	---
2.5 CP	304	50	50	50	50
		50	50	50	50
3	173	30	30	---	---
3 CP	423	40	40	40	40
		40	40	40	40
4 CP	490	40	40	40	40
6	869	30	30	30	30

[1] Maximum operating pressure differential (MOPD) in psi must not exceed maximum inlet pressure shown.

NOTE: Shaded areas indicate flanged valve bodies. All others are threaded.

Selection Data

Normally open, rising stem valves

Series Designation

Body Material >	Gray Iron	Cast Steel
Top Assembly Function	Sanctioned Service [1]	Sanctioned Service [1]
Manual Reset	STO-MNI STO-MNI-CP	STO-MNI-S STO-MNI-SCP
Automatic Reset	STO-ANI STO-ANI-CP	STO-ANI-S STO-ANI-SCP

[1] Sanctioned series carry FM sanctions for air, natural or liquified petroleum gases. They are normally approvable for clean fuel gases. Additionally, series with internal trim -2 are sanctioned for #1 and #2 fuel oils. Other gases and liquids may be sanctioned. Contact Maxon with your fuel analysis.

Temperature Limits

All these valves can handle **fluid temperatures** from -20°F (-28°C) to +140°F (+60°C). Oil viscosity not to exceed 5000 SSU.

Ambient temperature limits vary. The valves on this page can handle ambient temperatures from -20°F (-28°C) to +140°F (+60°C).

Operation

All of these electro-mechanical valves require a constant supply of electrical energy to their holding solenoids inside the top assembly actuators. Once the solenoid is energized, the STO-MNI (-CP) valves may be manually closed, or the STO-ANI (-CP) valves will automatically close.

Any interruption of the electrical power to either of these valves causes an immediate trip of the valve to its normally open position.

Features:

- Normally open
- Electrically actuated
- Rising stem body
- For vent and by-pass service



1" Series STO-ANI

Available Sizes and Pressure Ratings

Pipe Size (inches)	Body C _v Flow Factor	Maximum Inlet Pressure (psi) [1]			
		Gray Iron Bodies		Cast Steel Bodies	
		Clean Gases	Special Service	Clean Gases	Special Service
.75	20	125	65	---	---
1		125	65	125	65
1.5	53	70	65	70	65
2	86	70	65	70	65
		70	65	70	65
2.5 CP	304	50	50	50	50
		50	50	50	50
3 CP	423	40	40	40	40
		40	40	40	40
4 CP	490	40	40	40	40

[1] Maximum operating pressure differential (MOPD) in psi must not exceed maximum inlet pressures shown.

NOTE: Shaded areas indicate flanged valve bodies. All others are threaded.

Rising Stem Body/Trim Specifications

All Maxon Rising Stem Gate Valves carry a two-part trim identification (for example, Trim 1-1).

The first digit (a 1, 2, 3, 4 or 5 before the hyphen) identifies valve body and bonnet material as shown in Table 1 below.

The second digit (a 1, 2, or 3 after the hyphen) identifies the specific internals used, as described in Table 2 and identified in the sketches at right.

Internal trim -1 is normally suitable for clean fuel gases (for example, natural gas, propane, butane, clean atmosphere gases).

Internal trim -2 may be required for clean gases that require Viton seals or such gases as coke oven, refinery, town or off-gas, or #1 and #2 fuel oils. Contact Maxon with specific fuel analysis for prices and/or availability.

Internal trim -3 is designed for more corrosive environments such as digester gas, sour natural gas and landfill gas. Contact Maxon with specific fuel analysis for prices and/or availability.

Normally closed and normally open threaded and flanged body versions are identical in material specifications.

The drawing at right carries item numbers matching those in Tables 2, 3 & 4. This information is furnished for identification only, not for ordering parts.

WARNING: Do not attempt field repair of Maxon valve body or electro-mechanical actuator. Any field alterations void all warranties.

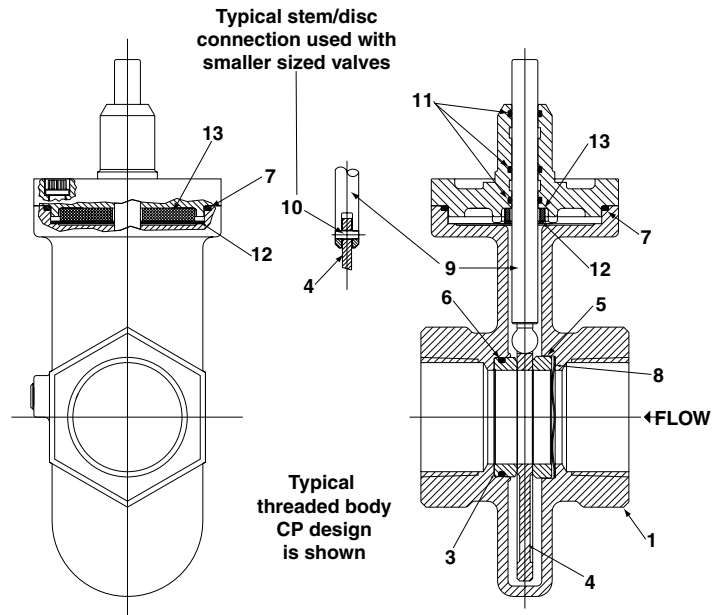

Table 1: Body (Item 1) and Bonnet (Item 2) Specifications

Body Description	Body 1-	Body 2-	Body 3-	Body 4-	Body 5 -
Material	Cast Iron, G3000, CL 30	Cast Steel	Cast Iron, G3000, CL 30	Cast Steel	Stainless Steel
Specifications	ASTM A159 / UL 429	ASTM A216-WCB / UL 429	ASTM A159 / UL 429	ASTM A216-WCB / UL 429	A351-CF8M
Special Coating	---	---	Electroless Nickel-Coated	Electroless Nickel-Coated	---

Table 2: Internal Trim Specifications for Trim -1

Item No.	Description	Trim: -1			
		3/4" - 2"	2-1/2", 3"	2-1/2" - 4" CP	6"
3	Seat	#440-F Stainless Steel	#416 Stainless Steel	#440-F Stainless Steel	#303 Stainless Steel
4	Disc	80-55-06 Ductile Iron	80-55-06 Ductile Iron	80-55-06 Ductile Iron	80-55-06 Ductile Iron
5	Follow Ring	Lead alloy (nickel plated)	Ductile Iron (nickel plated)	Low Carbon Steel (nickel plated)	Low-Carbon Steel (nickel plated)
6	Seat O-ring	Buna N	Buna N	Buna N	Buna N
7	Bonnet O-ring	Buna N	Buna N	Buna N	Steel
8	Wavy-Spring Washer	#302 Stainless Steel	#302 Stainless Steel	#302 Stainless Steel	#302 Stainless Steel
9	Stem	Type 630 Stainless Steel	Type 630 Stainless Steel	Type 630 Stainless Steel	Type 630 Stainless Steel
10	Stem/Disc Pins	High Carbon Steel (hardened)	High Carbon Steel (hardened)	---	Shear-Proof Steel
11	Stem O-rings	Buna N	Buna N	Buna N	Buna N
12	Striker Plate	#17-7 Stainless Steel	#17-7 Stainless Steel	#17-7 Stainless Steel	Carbon Steel
13	Bumper	Buna N	Buna N	Buna N	Buna N

Rising Stem Body/Trim Specifications

Table 3: Internal Trim Specifications for Trim -2

Item No.	Description	Trim: -2		
		.75" – 2"	2.5" – 4" CP	6"
3	Seat	#303 SS (hard faced)	#303 SS (hard faced)	#303 SS (hard faced)
4	Disc	80-55-06 Ductile Iron (chrome plated)	80-55-06 Ductile Iron (chrome plated)	80-55-06 Ductile Iron (chrome plated)
5	Follow Ring	303 SS (chrome plated)	303 SS (chrome plated)	303 SS (chrome plated)
6	Seat O-ring	Viton	Viton	Viton
7	Bonnet O-ring	Viton	Viton	Steel
8	Wavy-Spring Washer	#302 Stainless Steel	#302 Stainless Steel	#302 Stainless Steel
9	Stem	Type 630 Stainless Steel	Type 630 Stainless Steel	Type 630 Stainless Steel
10	Stem/Disc Pins	#420 Stainless Steel	---	Shear-Proof Steel
11	Stem O-rings	Viton	Viton	Viton
12	Striker Plate	#17-7 Stainless Steel	#17-7 Stainless Steel	Carbon Steel
13	Bumper	Viton	Buna N*	Viton

*For oxygen service, bumper material is EPDM

Table 4: Internal Trim Specifications for Trim -3

Item No.	Description	Trim: -3		
		.75" – 2"	2.5" – 4" CP	6"
3	Seat	PEEK	PEEK	PEEK
4	Disc	A351-CF8M	A351-CF8M	A351-CF8M
5	Follow Ring	PEEK	PEEK	PEEK
6	Seat O-ring	Viton	Viton	Viton
7	Bonnet O-ring	Viton	Viton	Viton
8	Wavy-Spring Washer	#302 Stainless Steel	#302 Stainless Steel	#302 Stainless Steel
9	Stem	Type 630 Stainless Steel	Type 630 Stainless Steel	Type 630 Stainless Steel
10	Stem/Disc Pins	---	---	---
11	Stem O-rings	Viton	Viton	Viton
12	Striker Plate	#17-7 Stainless Steel	#17-7 Stainless Steel	#17-7 Stainless Steel
13	Bumper	Viton	Buna N*	Viton

*For oxygen service, bumper material is EPDM

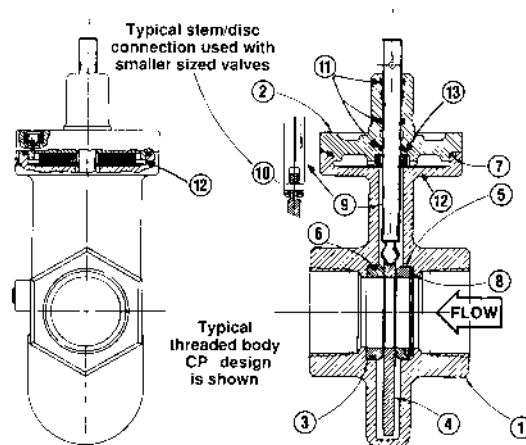

Swinging Gate Body/Trim Specifications

Trim identification of Maxon Swinging Gate Shut-Off Valves is two-part. The first digit before the hyphen is a number (1, 2, 3 or 4) identifying body material as shown in Table 1 below. The second digit after the hyphen identifies a trim utilizing the materials indicated in Table 2 below.

Standard sanctioned valves incorporating a *cast iron body* will normally be identified by trim 1-B or 1-D. Sanctioned valves with *steel body* will normally be trim 2-D.

Non-sanctioned services or unusual applications may require upgrading of internal trim. Contact Maxon with specific fuel analysis for price and availability.

The drawings shown carry item numbers matching those in Table 2. This information is furnished for identification only, not for ordering parts.

WARNING: Do not attempt field repair of Maxon valve body or electro-mechanical top actuator. Any field alterations void all warranties.

Table 1: Body (Item 1) Specifications

Body Description	Body 1-	Body 2-	Body 3-	Body 4-
Material	Cast Iron, G3000, CL 30	Cast Steel	Cast Iron, G3000, CL 30	Cast Steel
ASTM Spec	ASTM A159	ASTM A216-WCB	ASTM A159	ASTM A216-WCB
Special Coating	---	---	Electroless Nickel-Coated	Electroless Nickel-Coated

Table 2: Internal Trim Material Specifications

Item No.	Part Description	For 1" & 1-1/4" Valves	
		Trim: -B	Trim: -D
2	Hex Nut or Renewable Seat	Cast Iron with #420 Stainless Steel Seat Ring	Hard-Faced Steel
3	Stem Bushing	Zinc-Plated Steel	Zinc-Plated Steel
4	Stem	#416 Stainless Steel	#416 Stainless Steel
5	Stem Spring	#302 Stainless Steel	#302 Stainless Steel
6	Disc Carrier	Steel	Steel
7	Disc	Nodular Iron	Hard-Faced Steel
8	Stem O-rings	Viton	Viton
9	Disc Spring	#302 Stainless Steel	#302 Stainless Steel
10	Inner Stem Thrust Ring	Teflon	Teflon
11	Back-up O-rings	Teflon	Teflon
12	Body Gaskets	Soft Iron	Soft Iron
13	Stem Bushing Gasket	Soft Iron	Soft Iron
14	Body O-ring	Viton	Viton

Typical construction of 1" and 1.25" screwed body valves

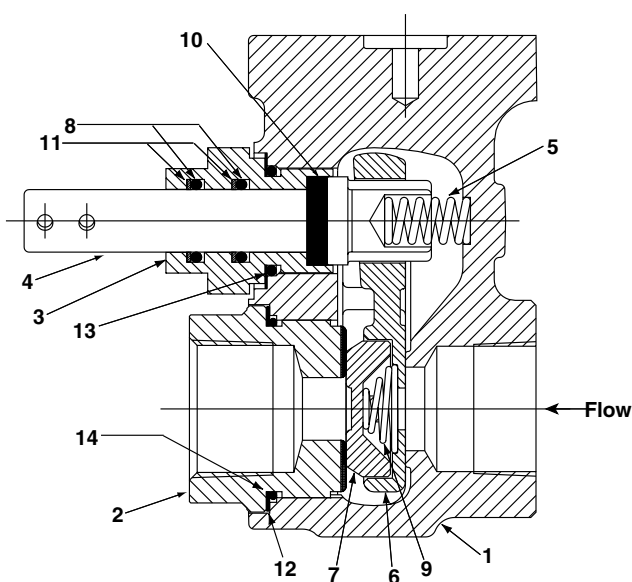

Component Identification

General Maintenance and Spare Parts

All safety devices should be tested at least monthly* and more often if deemed advisable. Periodic testing for tightness of manual or motorized shut-off valve closure is equally essential.

*per NFPA 86-Appendix B-4 (1995)

These Maxon valves are designed for long trouble-free service. Only items shown as suggested spare parts are considered field replaceable.

WARNING: Do not attempt field repair of valve body, top assembly or motor drive unit. Any alterations void all warranties.

To determine suggested spare parts, identify series designation and serial number from the valve's nameplate. Refer to the illustration and legend below to identify suggested spare parts.

To order, specify:

1. Quantity
2. Assembly part number (if available)
3. Description
4. Electrical specification
5. Full nameplate information (from existing valve)

Normally closed valve designation

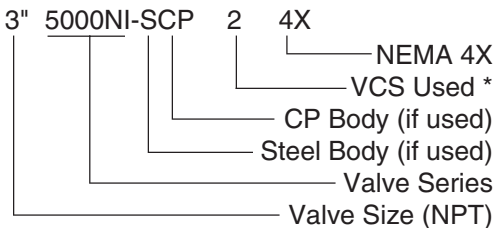

*Signal Switch legend:

- 0 No Switch
- 1 VCS-1 Switch
- 2 VCS-2 Switch

Normally open valve designation

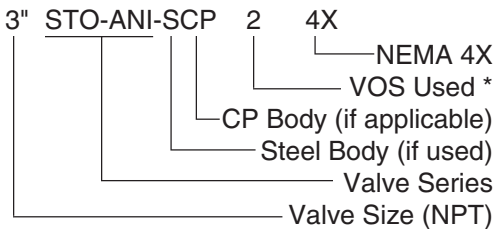

*Signal Switch legend:

- 0 No Switch
- 1 VOS-1 Switch
- 2 VOS-2 Switch

Manual Reset

Note: Drawings are illustrative only. Actual valves may vary slightly.

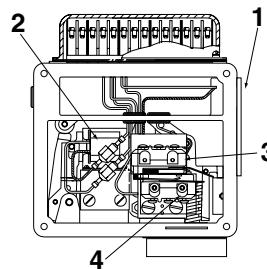

Series 808NI

Automatic Reset

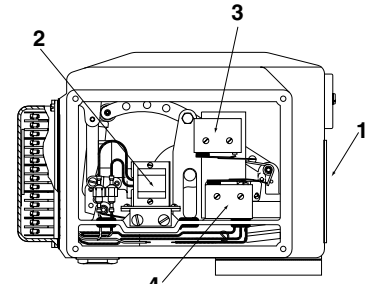

Series 5000NI

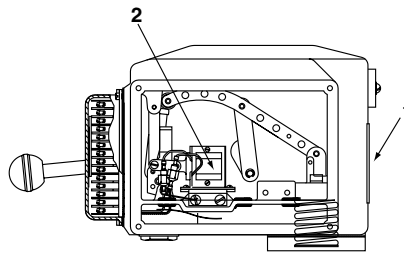

Series 808NI-CP

Legend:

- 1 – Nameplate
- 2 – Solenoid
- 3 – VCS signal switch for normally closed valve; VOS for normally open valve
- 4 – VOS motor limit/signal switch for normally closed valve; VCS for normally open valve



Nameplate (typical)

(shown for listed valves; others similar)

Nameplate designation does not reflect external accessory items or motor limit switch

Electrical Data for normally closed valves

General

All Maxon shut-off valves are electrically actuated from a power source, normally through the flame safeguard and/or safety control circuits.

Standard valve assemblies include an internal holding solenoid for 115 volt 50/60 hertz AC power. (230 volt 50/60 hertz available upon request.)

The solenoid is energized whenever the valve is powered. The motor operator on automatic reset versions is powered only during the opening stroke.

Switch wiring diagram (reproduced below) is part of each valve assembly, summarizing electrical data and a full complement of optional signal switches.

Diagram shows valve in its normally closed (at rest) position. The indicated internal wiring is present only when the appropriate auxiliary switches are specified. Automatic reset valves always include a VOS-1 SPDT valve open motor limit switch.

Good practice *normally* dictates that auxiliary switches in valves used for safety shut-off functions should be used for signal duty **only**, not to operate additional safety devices.

Signal switch designations:

VCS (Valve Closed Switch) is actuated at the end of the closing stroke. VCS-1 is SPDT; VCS-2 is 2 SPDT switches mounted side by side.

VOS (Valve Open Switch) is actuated at the end of the opening stroke. VOS-1 is SPDT; VOS-2 is 2 SPDT switches mounted side by side.

Switch amp ratings are shown on the schematic wiring diagram below.

DO NOT EXCEED rated amperage or total load shown.

Volt Ampere (VA) Ratings: Manual Reset

Valve		AC Operation 50Hz/60Hz	
Size	Series	Opening	Holding
.75" - 3"	808NI (-S)	24/15	24/15
1" - 1.25"	730NI (-S), 760NI		
2.5" - 6"	808NI(-S)CP	34/26	34/26

Volt Ampere (VA) Ratings: Automatic Reset

Valve		AC Operation 50Hz/60Hz	
Size	Series	Opening	Holding
.75" - 3"	5000NI (-S)	344/213	24/15
1" - 1.25"	4730NI (-S), 4760NI		
2.5" - 4"	5000NI(-S)CP	354/224	34/26

NOTE: Total VA of solenoid (manual reset valves) or solenoid and motor (motorized valves) must not exceed the limits shown.

Manual Reset Series:

- .75" - 3" Series 808NI (-S)
- 1" - 1.25" Series 730NI, 760NI
- 2.5" - 4" Series 808NI(-S)CP
- 6" Series 808NI (-S)

Automatic Reset Series:

- .75" - 3" Series 5000NI (-S)
- 1" - 1.25" Series 4730NI, 4760NI (-S)
- 2.5" - 4" Series 5000NI(-S)CP

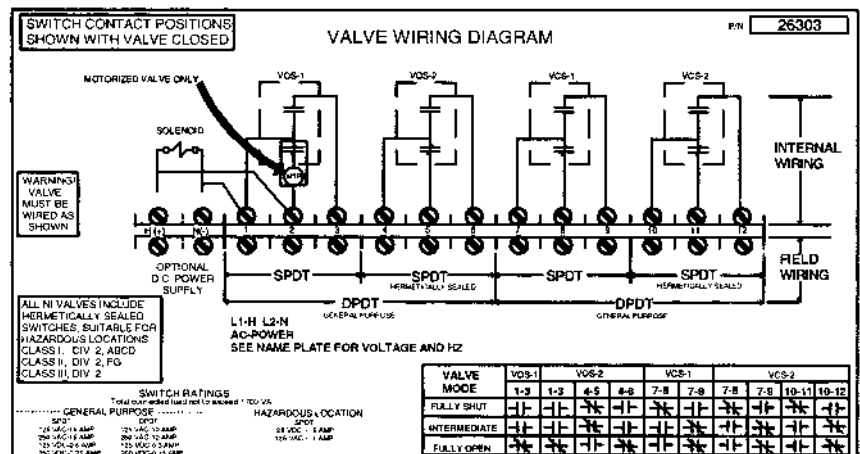

Electrical Data for normally open valves

General

All Maxon normally open vent valves are electrically actuated from a power source, normally through the flame safeguard and/or safety control circuits.

Standard valve assemblies include an internal holding solenoid for 115 volt 50/60 hertz AC power. (230 volt 50/60 hertz available upon request.)

The solenoid is energized whenever the valve is powered. The motor operator on automatic reset version is powered only during the closing stroke.

Switch wiring diagrams (reproduced below and on next page) are part of each valve assembly, summarizing electrical data and a full complement of optional signal switches.

Diagrams show valve in its normally open (at rest) position. The indicated internal wiring is present only when the appropriate auxiliary switches are specified.

Automatic reset valves always include a VCS-1 SPDT valve closed motor limit switch.

Good practice *normally* dictates that auxiliary switches in valves used for safety shut-off functions should be used for signal duty **only**, not to operate additional safety devices.

Signal switch designations:

VCS (Valve Closed Switch) is actuated at the end of the closing stroke. VCS-1 is SPDT; VCS-2 is 2 SPDT switches mounted side by side.

VOS (Valve Open Switch) is actuated at the end of opening stroke. VOS-1 is SPDT; VOS-2 is 2 SPDT switches mounted side by side.

Switch amp ratings are shown on the schematic wiring diagrams below and on the next page.

DO NOT EXCEED rated amperage or total load shown.

Volt Ampere (VA) Ratings: Manual Reset

Valve		AC Operation 50Hz/60Hz	
Size	Series	Opening	Holding
.75" - 3"	STO-MNI (-S)	24/15	24/15
2.5" - 4"	STO-MNI-(S)CP	34/26	34/26

Volt Ampere (VA) Ratings: Automatic Reset

Valve		AC Operation 50Hz/60Hz	
Size	Series	Opening	Holding
.75" - 3"	STO-ANI (-S)	344/213	24/15
2.5" - 4"	STO-ANI-(S)CP	354/224	34/26

NOTE: Total VA of solenoid (manual reset valves) or solenoid and motor (automatic reset valves) must not exceed the limits shown.

Manual Reset Series

- .75" - 3" Series STO-MNI (-S)
- 2.5" - 4" Series STO-MNI-(S)CP

Automatic Reset Series

- .75" - 3" Series STO-ANI (-S)
- 2.5" - 4" Series STO-ANI-(S)CP

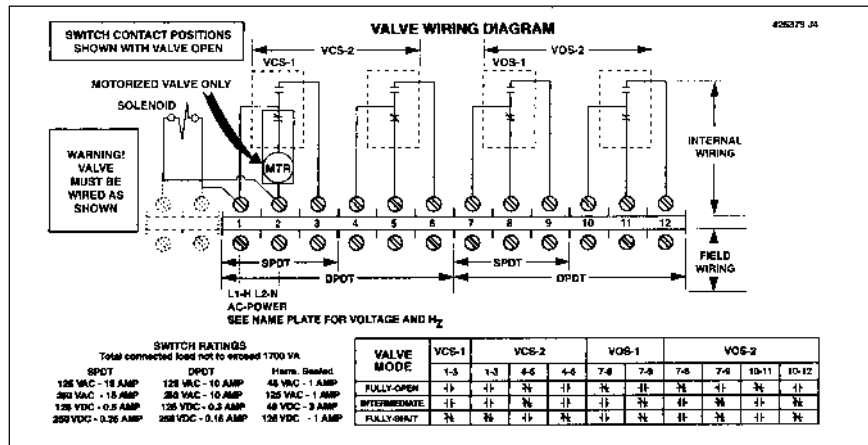

Dimensions (in Inches)

.75" through 1.5" valves with rising stem bodies

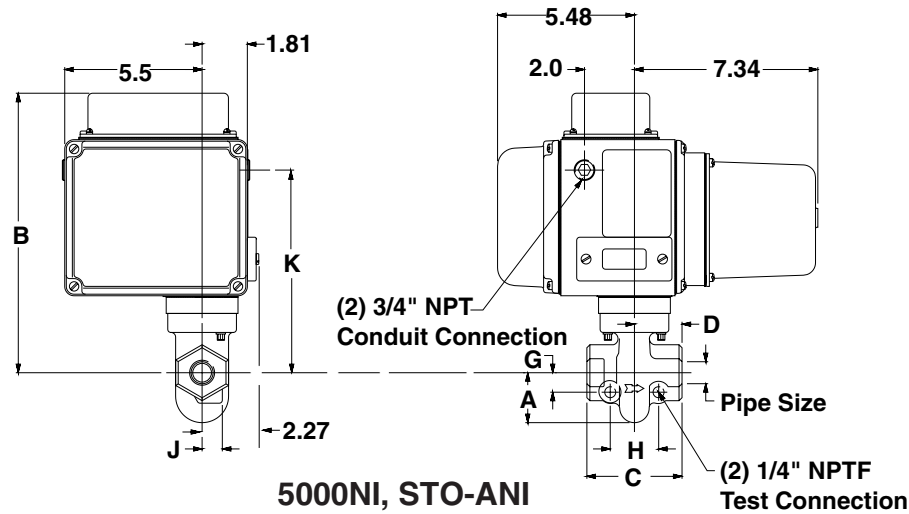

Available Top Assembly Positions

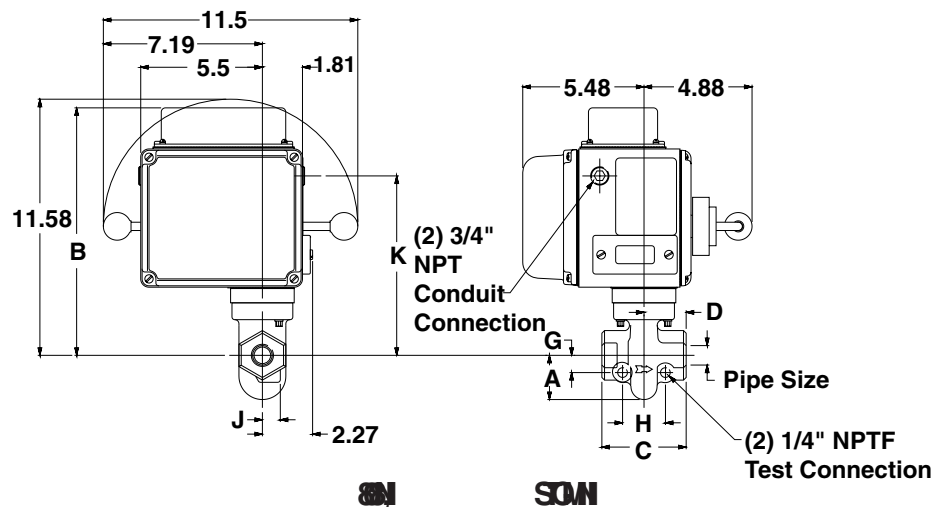
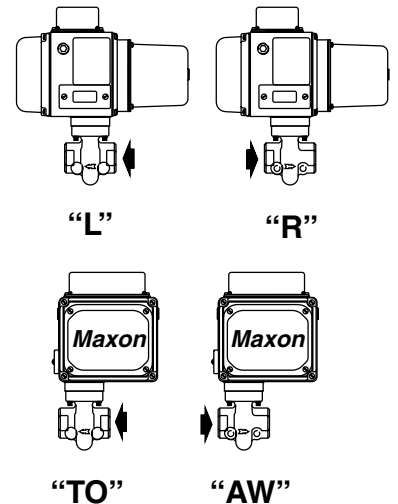

NOTE: 2.75" needed for terminal block cover removal.

Pipe Size	Valve Series	A	B	C	D	G	H	J	K	R
.75"	808NI & STO-MNI									11.58
	5000NI & STO-ANI									---
1"	808NI (-S) & STO-MNI (-S)	2.00	12.25	3.81	1.90	.78	1.94	.81	8.11	11.58
	5000NI (-S) & STO-ANI (-S)									---
1.25"	808NI	2.44	12.81	4.00	2.00	.22	2.12	1.56	8.67	12.14
	5000NI									---
1.5"	808NI (-S) & STO-MNI (-S)	2.69	13.31			.38		1.68	9.14	12.61
	5000NI (-S) & STO-ANI (-S)						---			

Dimensions (in Inches)

2" through 3" valves with rising stem bodies

808NI & STO-MNI

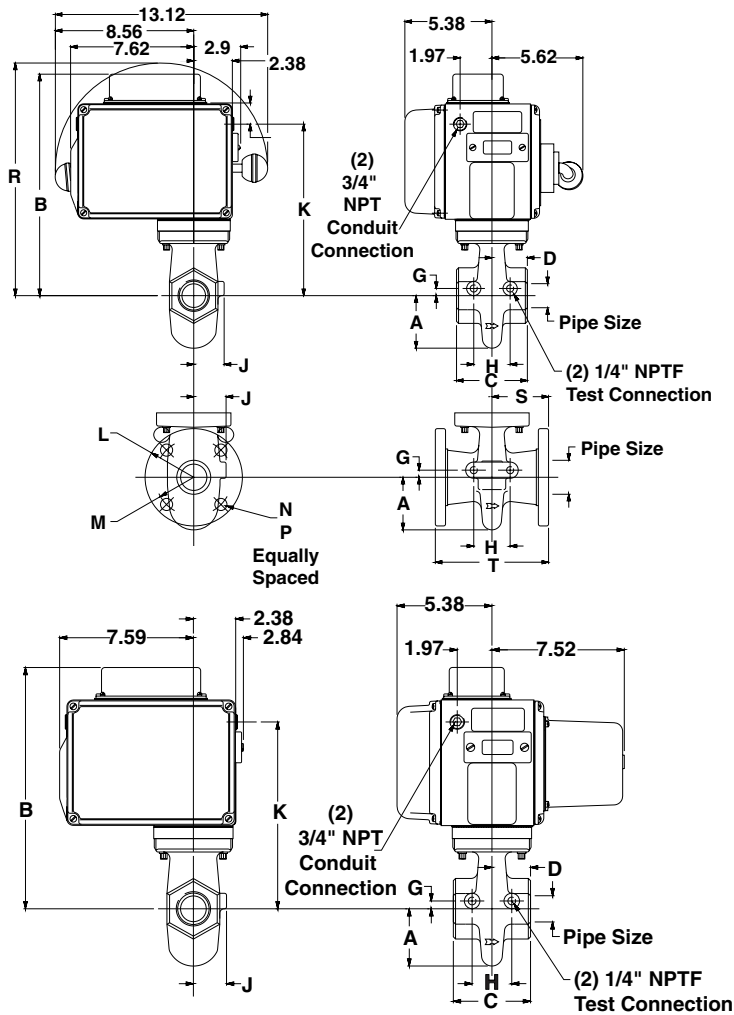

5000NI & STO-ANI

Available Top Assembly Positions

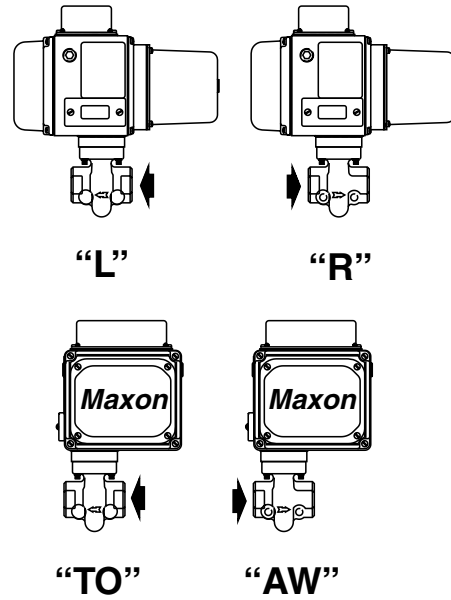

NOTE: 2.75" needed for terminal block cover removal.

Pipe Size	Valve Series	A	B	C	D	G	H	J	K	L	M	N	P	R	S	T
2"	808NI (-S) & STO-MNI (-S)	3.25	14.75	4.38	2.19	.44	2.25	1.88	10.6	---	---	---	---	14.38	---	---
	5000NI (-S) & STO-ANI (-S)			---	---					---	---	---				
2" F	808NI (-S) & STO-MNI (-S)	3.25	14.75	---	---	.44	2.25	1.88	10.6	3.01	2.38	.75	4	14.38	3.50	7.0
	5000NI (-S) & STO-ANI (-S)			---	---					---	---	---				
2.5"	808NI	3.50	14.62	5.0	2.5	.63	2.12	2.25	10.46	---	---	---	---	14.25	---	---
	5000NI			---	---					---	---	---				
2.5" F	808NI	3.50	14.62	---	---	.63	2.5	2.0	10.46	3.5	2.75	.75	4	14.25	3.75	7.5
	5000NI			---	---					---	---	---				
3"	808NI	2.94	14.86	5.19	2.59	.63	2.12	2.56	10.71	---	---	---	---	14.25	---	---
	5000NI			---	---					---	---	---				

Dimensions (in Inches)

1" and 1.25" valves with swinging gate bodies

Series 730NI, 760NI

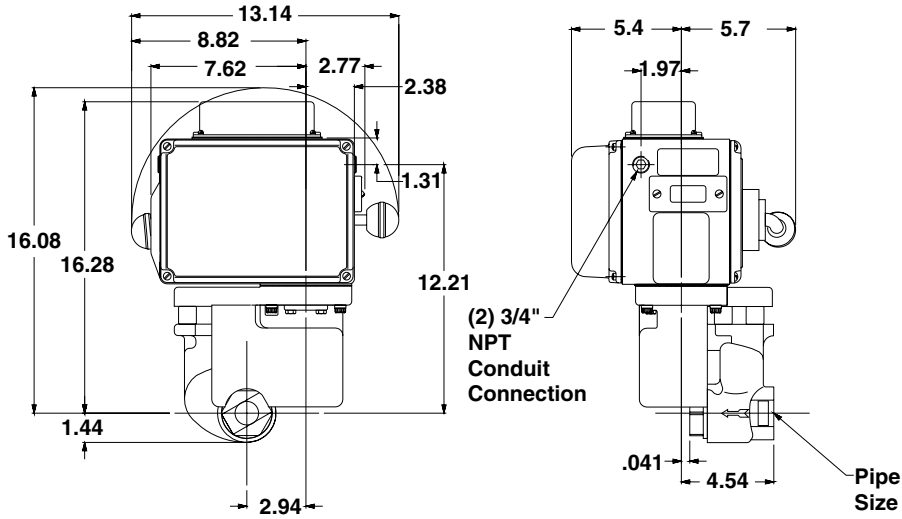

Available Top Assembly Positions

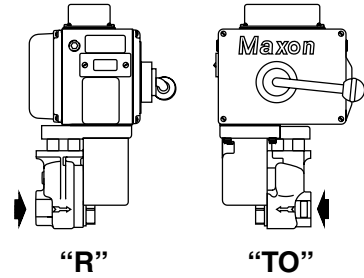

Series 4730NI, 4760NI

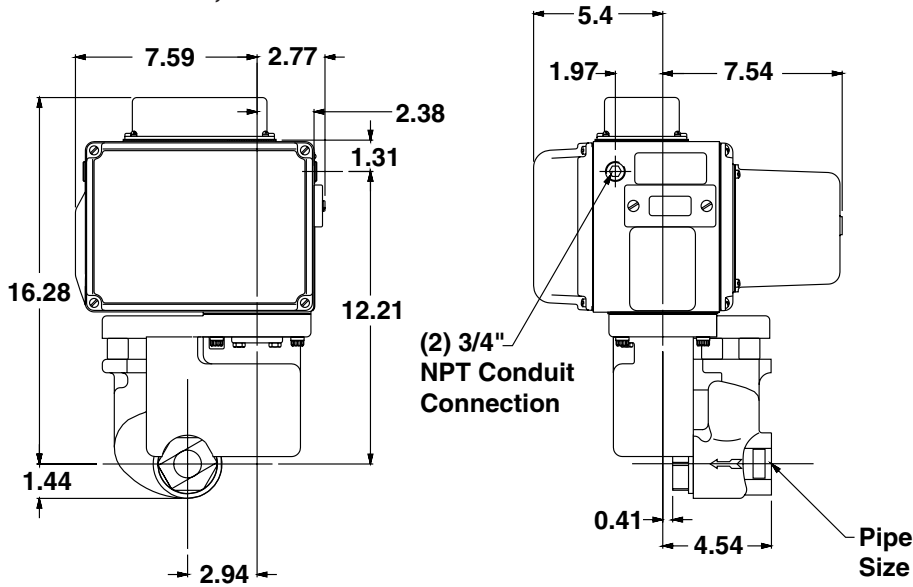

NOTE: 2.75" needed for terminal block cover removal.

Auxiliary Signal Switches

All Maxon NI Valves may be equipped with internally-mounted hermetically-sealed signal switch(es) to provide a proof-of-open or proof-of-closure valve position indication. Auxiliary signal switches indicate

when valve is open or closed and are normally connected electrically into your control panel lights or warning device circuit(s).

For normally closed valves:

VCS hermetically-sealed (Valve Closed Switch) is actuated when valve is fully shut. It is the upper, inverted snap-switch mounted on rear on switch bracket. VCS-1 is an SPDT (single-pole, double-throw) switch. VCS-2 is (2) SPDT switches mounted side by side. All contacts are available for external circuitry.

VOS hermetically-sealed (Valve Open Switch) is actuated when valve reaches full-open. It is the lower

snap-switch mounted on front of switch bracket. VOS-1 is an SPDT switch. On automatic reset valves, its normally closed contact serves as a motor limit switch and is not available for external circuitry. On manual reset valves, normally closed contact is available for external circuitry. VOS-2 is (2) SPDT switches mounted side by side, used in lieu of VOS-1 for additional contacts.

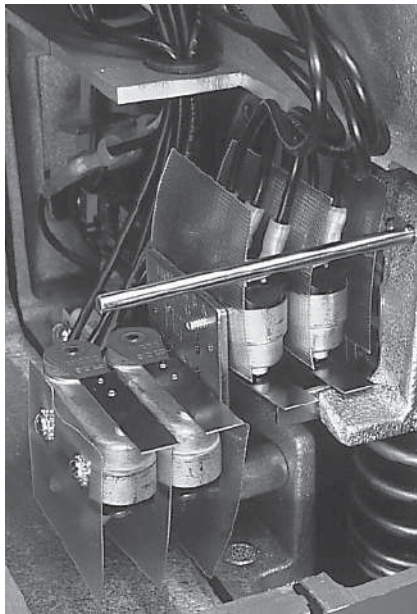

Valve Shut

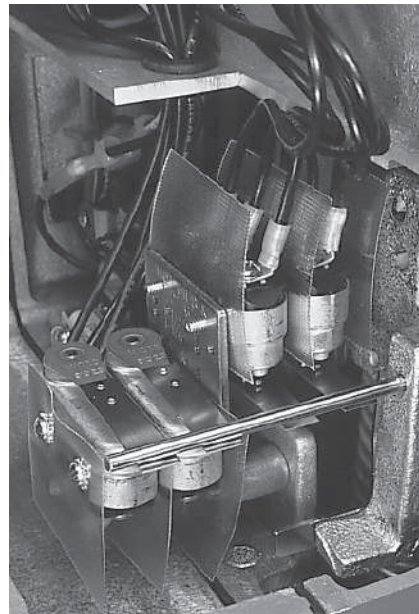

Valve Open

**Photos above of normally closed valve
(typical for Series 808NI (-S), 5000NI (-S), 730NI (-S), 760NI, 4730NI (-S), 4760NI)**

Auxiliary Signal Switches

For normally open valves:

VOS hermetically-sealed (Valve Open Switch) is actuated when valve is fully open. It is the upper, inverted snap-switch mounted on rear of switch bracket. VOS-1 is an SPDT (single-pole, double-throw) switch. VOS-2 is (2) SPDT switches mounted side by side. All contacts are available for external circuitry.

VCS hermetically-sealed (Valve Closed Switch) is actuated when valve reaches fully closed. It is the

lower snap-switch mounted on front of switch bracket. VCS-1 is an SPDT switch. On automatic reset valves, its normally closed contact serves a motor limit switch and is not available for external circuitry. On manual reset valves, normally closed contact is available for external circuitry. VCS-2 is (2) SPDT switches mounted side by side, used in lieu of VCS-1 for additional contacts.

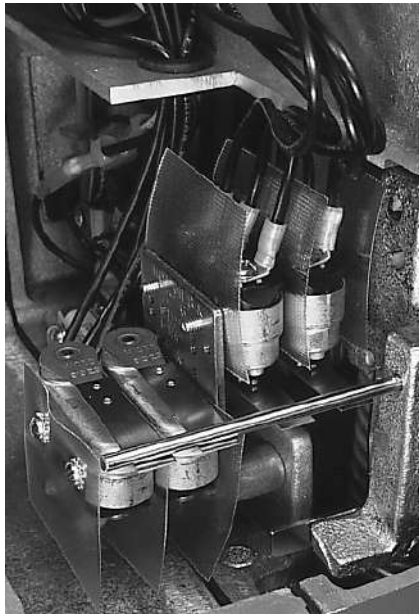

Valve Shut

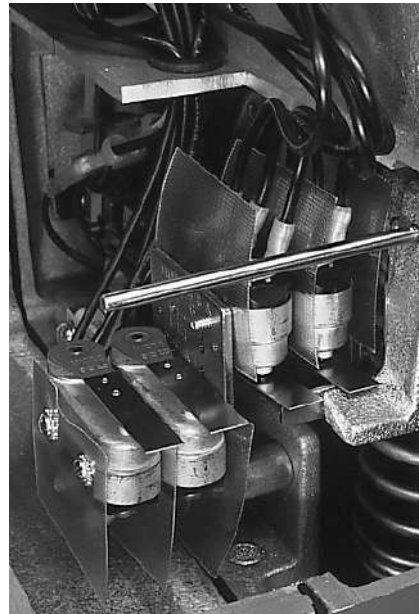

Valve Open

**Photos above of normally open valve
(typical for Series STO-MNI-(-S)CP, STO-ANI-(S)CP)**

Tandem Arrangements (for simultaneous opening of main and blocking valves)

General

Wherever insurance underwriters or other regulatory groups require the use of a double-valve or "block-and-bleed" system, but manual operation is preferred to the use of automatic reset valves, operation can be simplified by adding a tandem arrangement to a pair of Maxon manual reset shut-off valves.

A linkage overtravel spring in the tandem arrangement latches the blocking valve just before the main valve is latched, assuring latching of both valves.

If it is necessary to locate a tandem valve above arms reach, an overhead wheel and chain assembly may be added which includes a loop of chain accessible to operating personnel.

To order

Valves are to be specified in the usual manner and must be in top assembly position TO or AW.

VOS and VCS switches must be included on the main valve and a VOS switch on the blocking valve to permit electrical connection as shown in the wiring schematic illustrated below.

If **overhead wheel and chain assembly** is also required, specify loop length to reach appropriate operating position. Extra chain (in one foot increments) may be specified.

Center line distance between valves must be within the ranges indicated in Table 1 and shown in sketch below and must be specified at the time of order.

Wiring Schematic

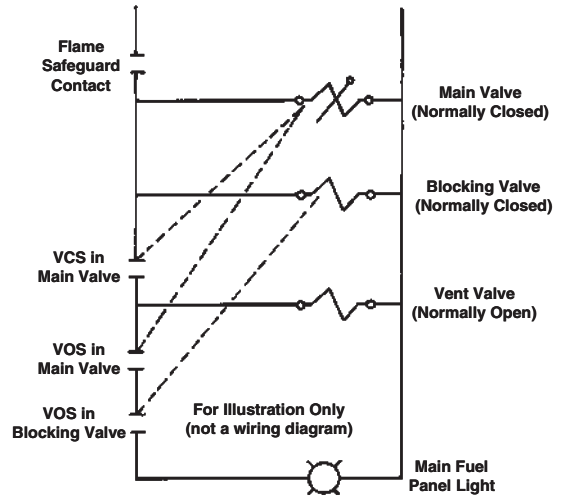

Main valve and blocking valve wired in parallel.
VCS Switch on main valve powers vent valve.
VOS Switches on main and blocking valves wired in series to signal light.

Table 1: Allowable Valve Spacing for Tandem Arrgt.

Valve Size	Minimum C-C	Maximum C-C
.75" - 1.5"	18"	24"
2" - 3"	20"	27"
4" & 6"	27"	33"

Tandem Arrangement with Overhead Wheel & Chain

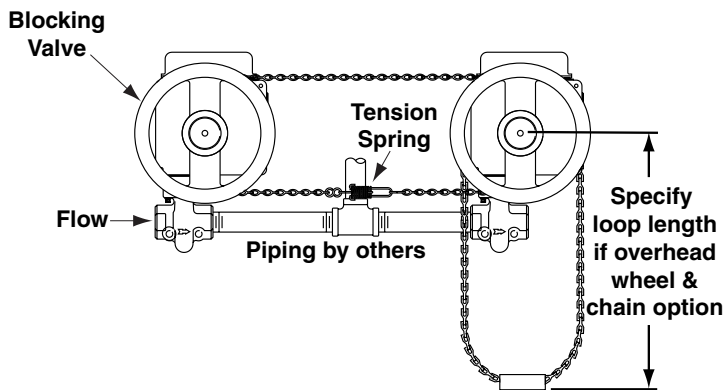

Tandem Arrangement

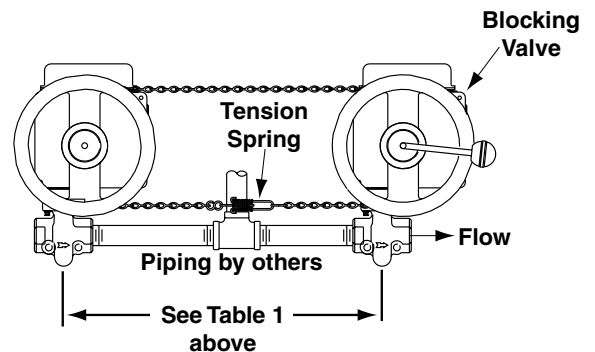

Overhead Wheel & Chain Assembly

Overhead wheel and chain assembly allows operation of a manual reset valve in an otherwise inaccessible overhead location. A wheel is mounted onto the handle of the valve. The attached chain is weighted on one end and has a paddle handgrip on the other.

Once the valve is electrically energized, pulling down on the paddle will open normally closed versions or close normally open versions.

Maxon valve's free-handle design permits valve to trip to its rest position on any power interruption.

Wheel and chain assembly includes a length of chain to position the paddle handgrip slightly below pipe centerline. A standard length of 7 feet of chain is included with CP and larger valve sizes and 5 feet is included with all other valves. Extra chain (in one foot increments) may be specified to fit your specific location.

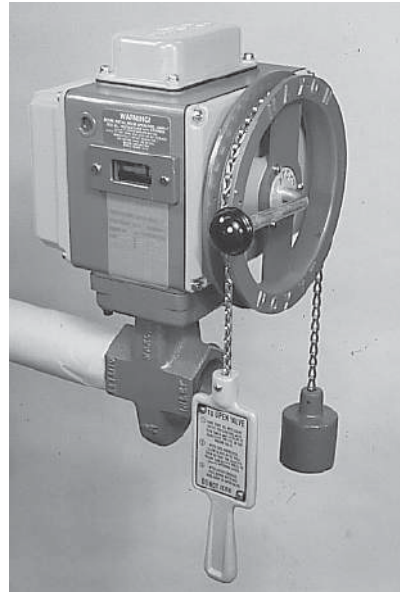

Approximate envelope dimensions *(nominal, in inches)*

Swinging gate valves

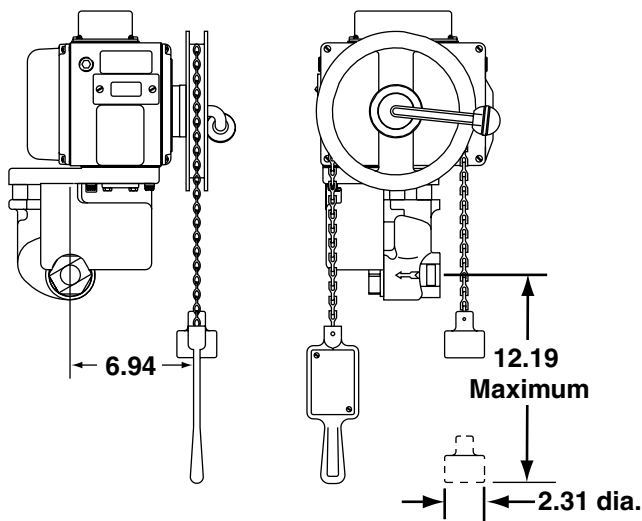

Rising stem valves

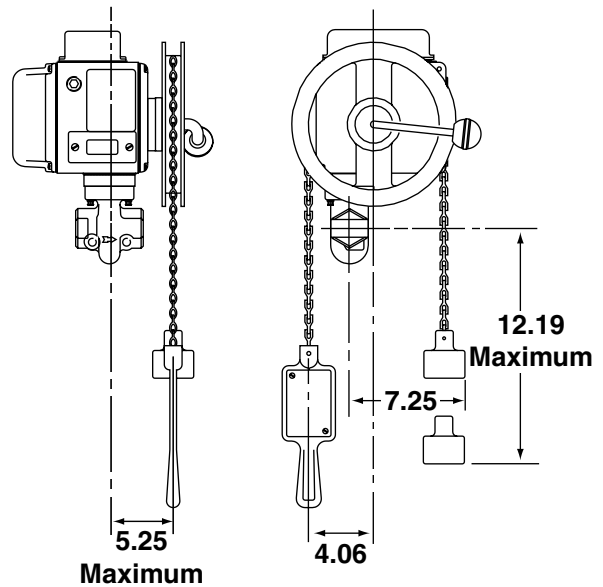

NOTE: Overhead wheel & chain can only be mounted on swinging gate valves with the top assembly position TO.

NEMA 4X Hardware Kit

General Information

Maxon "NI" Valves are available with hardware modifications which make it NEMA 4X compliant.

On automatic valves, these kits may be installed in the field. However, due to the linkage set-up of manual valves, this kit is only available as a factory installed accessory.

These kits consist of new corrosion resistant stainless steel external fasteners for all covers.

When ordering the factory installed NEMA 4X kit for manual valves, the kit will include a new handle made of corrosion resistant stainless steel.

When these kits are factory installed, the name-plate will indicate NEMA 4X in the designation block as shown on Page 6218.

Cover	Torque (in-lbs)
#10-24 Operator Cover	25
.25"-20 All other access covers	50
.25"-20 Extended Access Cover Plate	96

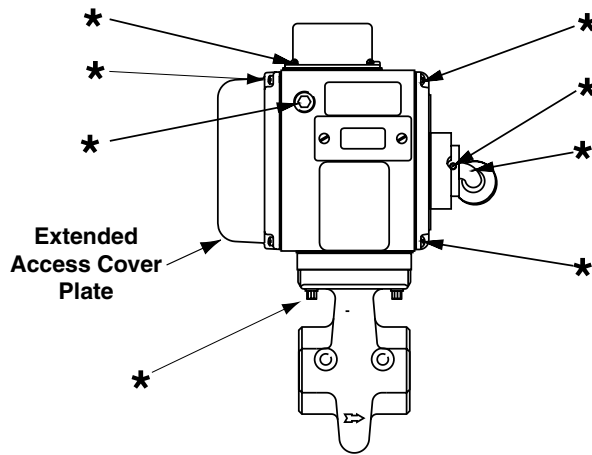

808NI, STO-MNI, 730NI

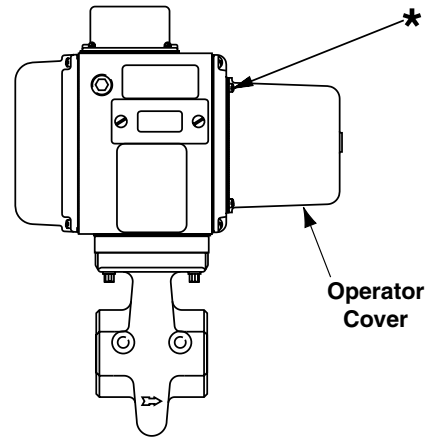

5000NI, STO-ANI, 4730NI

* Asterisks indicate fasteners included in kit (for appropriate valve series)

Notes