

March 2022

# T205 Series Tank Blanketing Regulators

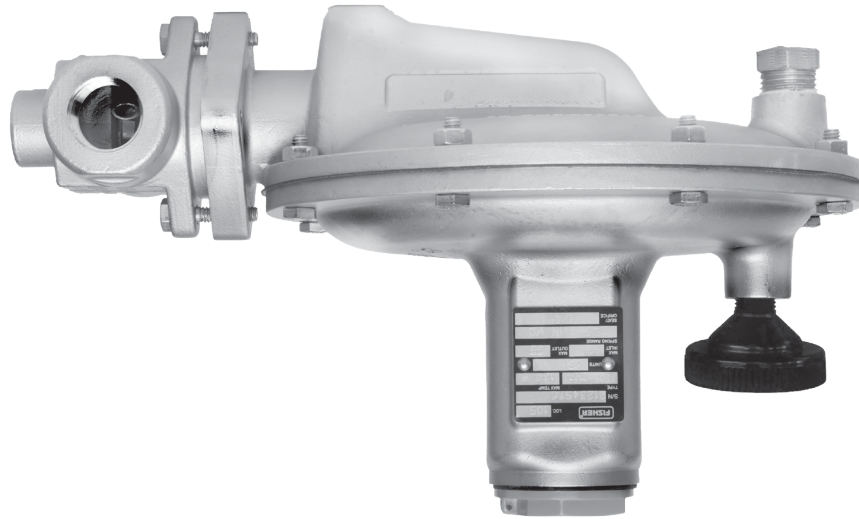

Figure 1. Type T205 Tank Blanketing Regulator

## Contents

Features	1
Introduction	1
Specifications	2
Principle of Operation	2
Installation	6
Overpressure Protection	6
Capacity Information	6
Ordering Information	31
Ordering Guide	31

## Features

### Low-pressure setting and fast speed of response –

T205 Series regulator has a low-pressure setting as low as 1 in. w.c. / 2.5 mbar. It can respond quickly to downstream flow demand and pressure changes due to direct-operated structure.

**Accurate control and small lockup pressure** – Large diaphragm area provides very accurate throttling control at low pressure settings. An added benefit of lever style regulator is that it can shut off the process fluid using small lockup pressure.

**Arctic Temperatures** – Constructions for process temperatures as low as -76°F / -60°C available by request.

**Multiple applications** – T205 Series regulator can be used for a wide variety of gases including air, nitrogen, natural gas, sour gas (NACE Construction), butane and propane.

**Corrosion resistance** – Multiple regulator constructions are available in a variety of materials for compatibility with corrosive process gases.

**FDA/USP Class VI/ADI-free** – Types T205 and T205M can be used in applications requiring clean regulator solutions. Constructions available with FDA/USP Class VI approved/ADI-free elastomers.

**Easy conversion between constructions** – Converts easily from the Types T205 and T205M to the Types T205H and T205HM with two O-rings and one machine screw.

**Sour gas service capability** – Available construction to meet NACE MR0175-2002.

## Introduction

T205 Series tank blanketing regulator is a direct-operated and spring-loaded regulator (Figure 1). The regulator prevents a stored liquid from vaporizing into the atmosphere, reduces liquid combustibility and prevents oxidation or contamination of the product by reducing its exposure to air. T205 Series maintains a slightly positive pressure and thereby reduces the possibility of tank wall collapse during pump out operation. T205 Series is available in two configurations: Types T205 and T205H for internal pressure registration and Types T205M and T205HM for external pressure registration.

# T205 Series

## Specifications

The Specifications section on this page provides the ratings and other specifications for the T205 Series. Factory specification such as type, maximum inlet pressure, maximum temperature, maximum outlet pressure, spring range and orifice size are stamped on the nameplate fastened on the regulator at the factory.

### Product Configurations

**Type T205:** Tank blanketing regulator with outlet pressure range of 1 in. w.c. to 7 psig / 2.5 mbar to 0.48 bar in seven different spring ranges and has internal pressure registration requiring no downstream control line

**Type T205M:** Similar to Type T205 but has a blocked throat and a downstream control line connection for external pressure registration

**Type T205H:** Similar to Type T205, except with inlet pressure equals outlet (casing) pressure (both 150 psig / 10.3 bar) and low temperature to -20°F / -29°C

**Type T205HM:** Similar to Type T205M, except with inlet pressure equals outlet (casing) pressure (both 150 psig / 10.3 bar) and low temperature to -20°F / -29°C

### Body Sizes and End Connection Styles

See Table 1

### Maximum Allowable Inlet Pressure<sup>(1)</sup>

See Table 1

### Maximum Operating Inlet Pressure<sup>(1)</sup>

See Table 2

### Maximum Outlet (Casing) Pressure<sup>(1)</sup>

#### Types T205 and T205M

Gray cast iron: 35 psig / 2.4 bar

WCC Carbon steel, LCC Carbon steel or CF8M/CF3M Stainless steel: 75 psig / 5.2 bar

#### Types T205H and T205HM

WCC Carbon steel or CF8M/CF3M Stainless steel: 150 psig / 10.3 bar

### Outlet (Control) Pressure Range<sup>(1)</sup>

See Table 3

### Operating Outlet Pressure

See Table 4

### Shutoff Classification per ANSI/FCI 70-3-2004

Class VI (Soft Seat)

### Pressure Registration

Types T205 and T205H: Internal

Types T205M and T205HM: External

### Orifice Size and Flow Coefficients

See Table 5

### Body and Casing Materials

Gray cast iron, WCC Carbon steel, LCC Carbon steel and CF8M/CF3M Stainless steel<sup>(2)</sup>

### Trim Materials

See Table 4

### Flow Capacities

See Tables 7 to 10

### C<sub>v</sub> Coefficients

See Tables 11 and 12

### Material Temperature Capabilities<sup>(1)(3)(5)</sup>

#### Elastomer Parts

*Nitrile (NBR):*

-40 to 180°F / -40 to 82°C (Types T205 and T205M)

-20 to 180°F / -29 to 82°C (Types T205H and T205HM)

*Fluorinated Ethylene Propylene (FEP)<sup>(4)</sup>:*

-20 to 180°F / -29 to 82°C

*Fluorocarbon (FKM)<sup>(4)</sup>:*

40 to 300°F / 4 to 149°C

*Ethylene Propylene Diene (EPDM)<sup>(4)</sup>:*

-20 to 225°F / -29 to 107°C

*Perfluoroelastomer (FFKM)<sup>(4)</sup>:*

0 to 300°F / -18 to 149°C

#### Body Materials

Gray cast iron<sup>(4)</sup>: -20 to 300°F / -29 to 149°C

WCC Carbon steel: -20 to 300°F / -29 to 149°C

LCC Carbon steel: -40 to 300°F / -40 to 149°C

CF8M/CF3M Stainless steel:

-40 to 300°F / -40 to 149°C

### Spring Case Vent Connection

1/4 NPT

### Diaphragm Case Control Line Connection

(Types T205M and T205HM)

1/2 NPT

### Approximate Weight

17.7 lbs / 8 kg

1. The pressure/temperature limits in this Bulletin and any applicable standard or code limitation should not be exceeded.

2. Pipe nipples and flanges are 316 Stainless steel for flanged body assemblies.

3. See Table 4 for operating temperature ranges for available trim combinations.

4. Not available for Types T205H and T205HM.

5. Special low temperature constructions for process temperatures between -76 to 180°F / -60 to 82°C are available by request. The low temperature construction passed Emerson laboratory testing for lockup and external leakage down to -76°F / -60°C.

## Principle of Operation

T205 Series tank blanketing regulator controls the vapor space pressure over a stored liquid. When liquid is pumped out of the tank or vapors in the tank condense, the pressure in the tank decreases. Tank pressure is sensed by the actuator diaphragm. Spring force pushes the pusher post assembly, the valve disk moves away from the orifice, allowing the gas flow to increase to maintain tank pressure. See Figures 2 and 3.

When pressure in the tank increases, the actuator diaphragm is pushed. Through the action of the pusher post assembly, lever and valve stem, the valve disk moves closer to the orifice reducing gas flow.

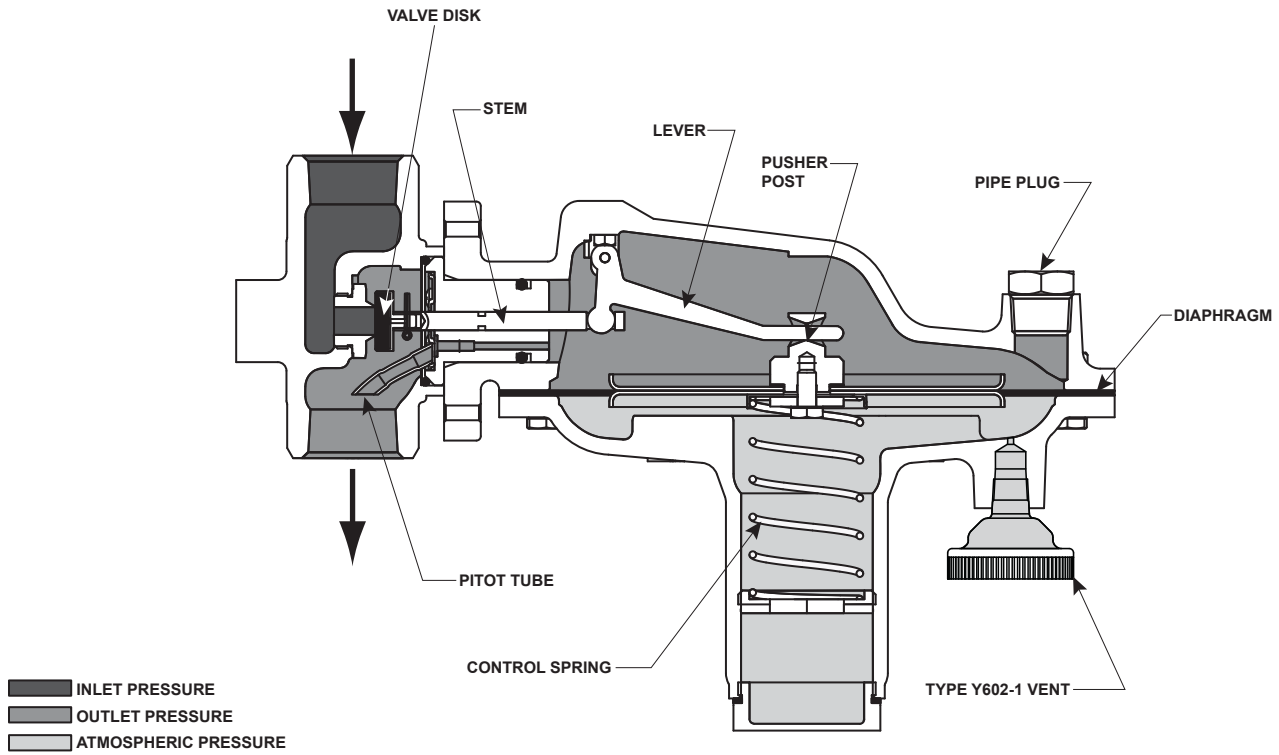

Figure 2. Type T205 with Internal Registration Operational Schematic

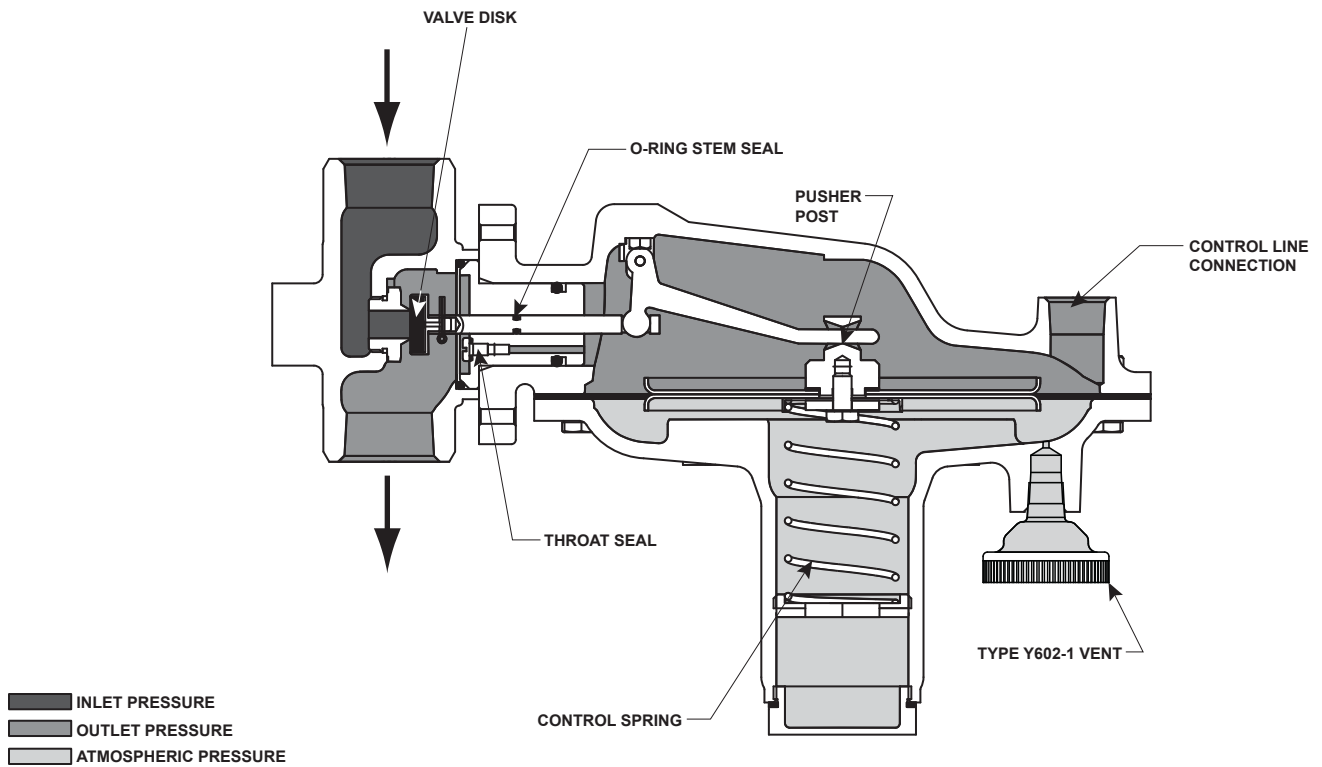

Figure 3. Type T205M with External Registration Operational Schematic

# T205 Series

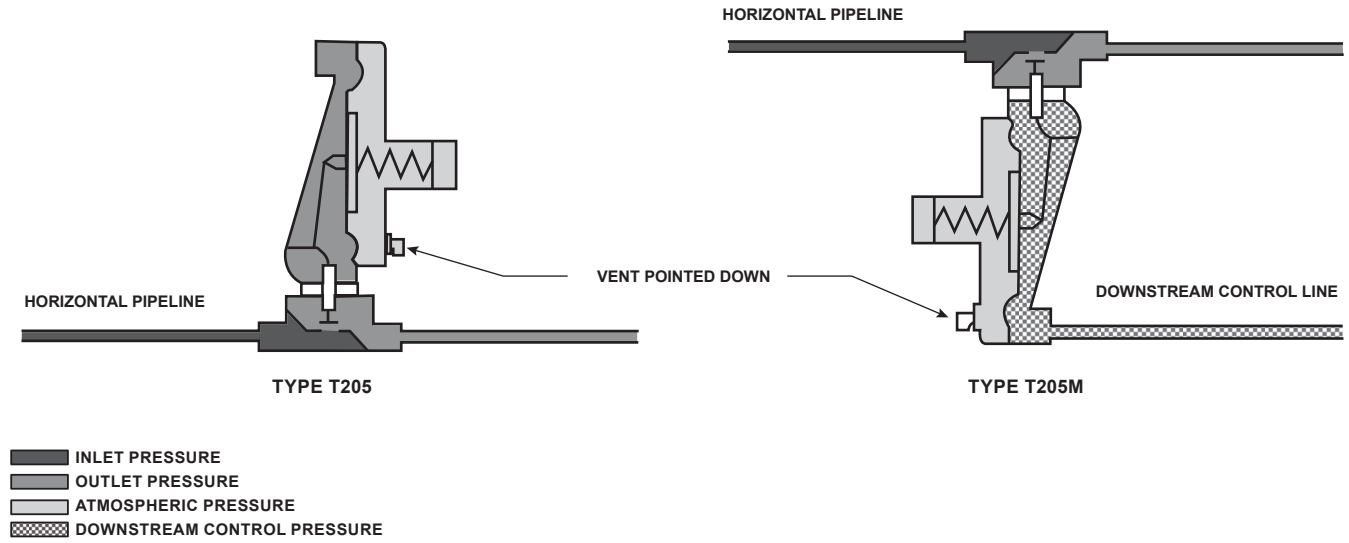

Figure 4. T205 Series Actuator Casing Drainage Schematic

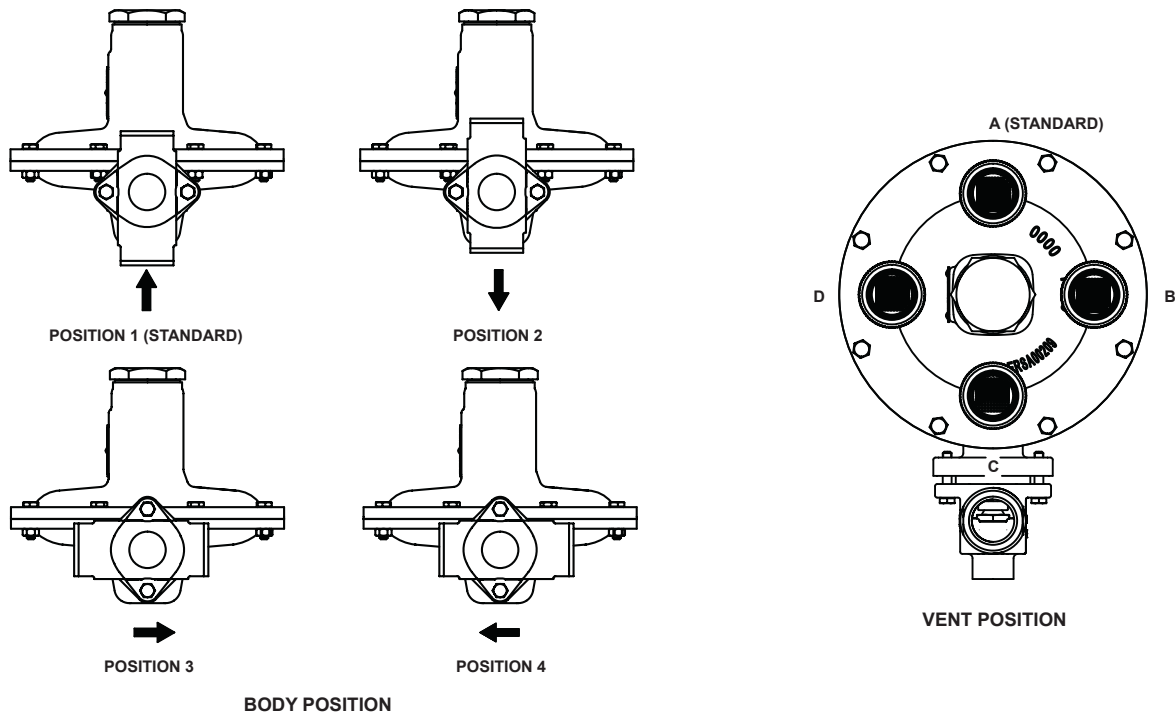

Figure 5. Body and Vent Orientation

**Table 1. Body Sizes, End Connection Styles and Maximum Allowable Inlet Pressure**

BODY SIZE		BODY MATERIAL	END CONNECTION STYLE <sup>(1)</sup>	MAXIMUM ALLOWABLE INLET PRESSURE	
In.	DN			psig	bar
3/4 or 1	20 or 25	Gray cast iron	NPT	150	10.3
		WCC Carbon steel	NPT	200 <sup>(3)</sup>	13.8 <sup>(3)</sup>
		LCC Carbon steel			
		CF8M/CF3M Stainless steel <sup>(2)</sup>			
3/4 or 3/4 x 1(4)	20 or 20 x 25	WCC Carbon steel, LCC Carbon steel, CF8M/CF3M Stainless steel <sup>(2)</sup>	CL150 RF, CL300 RF, PN 16/25/40 RF	200 <sup>(3)</sup>	13.8 <sup>(3)</sup>

1. All flanges are welded. Weld-on flange dimension is 14 in. / 356 mm face-to-face.  
 2. Pipe nipples and flanges are 316 Stainless steel for flanged body assemblies.  
 3. Inlet pressure is limited to 150 psig / 10.3 bar for Types T205H and T205HM.  
 4. 3/4 x 1 in. flanged construction uses 3/4 in. body.

**Table 2. T205 Series Maximum Operating Inlet Pressure**

ORIFICE SIZE		MAXIMUM OPERATING INLET PRESSURE <sup>(1)</sup>													
		1 to 2.5 In. w.c. / 2.5 to 6.2 mbar Outlet (Control) Pressure Setting		2.5 to 7 In. w.c. / 6.2 to 17 mbar Outlet (Control) Pressure Setting		7 to 16 In. w.c. / 17 to 40 mbar Outlet (Control) Pressure Setting		0.5 to 1.2 psig / 34 to 83 mbar Outlet (Control) Pressure Setting		1.2 to 2.5 psig / 83 to 172 mbar Outlet (Control) Pressure Setting		2.5 to 4.5 psig / 0.17 to 0.31 bar Outlet (Control) Pressure Setting		4.5 to 7 psig / 0.31 to 0.48 bar Outlet (Control) Pressure Setting	
In.	mm	psig	bar	psig	bar	psig	bar	psig	bar	psig	bar	psig	bar	psig	bar
<b>3/4 In. / DN 20 Body Size</b>															
1/8	3.2	200 <sup>(2)</sup>	13.8 <sup>(2)</sup>	200 <sup>(2)</sup>	13.8 <sup>(2)</sup>	200 <sup>(2)</sup>	13.8 <sup>(2)</sup>	200 <sup>(2)</sup>	13.8 <sup>(2)</sup>	200 <sup>(2)</sup>	13.8 <sup>(2)</sup>	200 <sup>(2)</sup>	13.8 <sup>(2)</sup>	200 <sup>(2)</sup>	13.8 <sup>(2)</sup>
1/4	6.4	125	8.62	175 <sup>(2)</sup>	12.1 <sup>(2)</sup>	200 <sup>(2)</sup>	13.8 <sup>(2)</sup>	200 <sup>(2)</sup>	13.8 <sup>(2)</sup>	200 <sup>(2)</sup>	13.8 <sup>(2)</sup>	200 <sup>(2)</sup>	13.8 <sup>(2)</sup>	200 <sup>(2)</sup>	13.8 <sup>(2)</sup>
3/8	9.5	60	4.14	80	5.52	200 <sup>(2)</sup>	13.8 <sup>(2)</sup>	200 <sup>(2)</sup>	13.8 <sup>(2)</sup>	200 <sup>(2)</sup>	13.8 <sup>(2)</sup>	200 <sup>(2)</sup>	13.8 <sup>(2)</sup>	200 <sup>(2)</sup>	13.8 <sup>(2)</sup>
1/2	13	30	2.07	40	2.76	125	8.62	150	10.3	200 <sup>(2)</sup>	13.8 <sup>(2)</sup>	200 <sup>(2)</sup>	13.8 <sup>(2)</sup>	200 <sup>(2)</sup>	13.8 <sup>(2)</sup>
9/16	14	20	1.38	30	2.07	100	6.89	125	8.62	200 <sup>(2)</sup>	13.8 <sup>(2)</sup>	200 <sup>(2)</sup>	13.8 <sup>(2)</sup>	200 <sup>(2)</sup>	13.8 <sup>(2)</sup>
<b>1 In. / DN 25 Body Size</b>															
1/8	3.2	200 <sup>(2)</sup>	13.8 <sup>(2)</sup>	200 <sup>(2)</sup>	13.8 <sup>(2)</sup>	200 <sup>(2)</sup>	13.8 <sup>(2)</sup>	200 <sup>(2)</sup>	13.8 <sup>(2)</sup>	200 <sup>(2)</sup>	13.8 <sup>(2)</sup>	200 <sup>(2)</sup>	13.8 <sup>(2)</sup>	200 <sup>(2)</sup>	13.8 <sup>(2)</sup>
1/4	6.4	100	6.89	150	10.3	150	10.3	150	10.3	200 <sup>(2)</sup>	13.8 <sup>(2)</sup>	200 <sup>(2)</sup>	13.8 <sup>(2)</sup>	200 <sup>(2)</sup>	13.8 <sup>(2)</sup>
3/8	9.5	40	2.76	80	5.52	150	10.3	150	10.3	200 <sup>(2)</sup>	13.8 <sup>(2)</sup>	200 <sup>(2)</sup>	13.8 <sup>(2)</sup>	200 <sup>(2)</sup>	13.8 <sup>(2)</sup>
1/2	13	30	2.07	40	2.76	125	8.62	150	10.3	200 <sup>(2)</sup>	13.8 <sup>(2)</sup>	200 <sup>(2)</sup>	13.8 <sup>(2)</sup>	200 <sup>(2)</sup>	13.8 <sup>(2)</sup>
9/16	14	20	1.38	15	1.03	100	6.89	125	8.62	200 <sup>(2)</sup>	13.8 <sup>(2)</sup>	200 <sup>(2)</sup>	13.8 <sup>(2)</sup>	200 <sup>(2)</sup>	13.8 <sup>(2)</sup>

1. At maximum inlet pressure, minimum achievable setpoints may vary based on process conditions.  
 2. Inlet pressure is limited to 150 psig / 10.3 bar for Gray cast iron bodies or for Types T205H and T205HM.

**Table 3. Outlet (Control) Pressures and Spring Part Numbers**

OUTLET (CONTROL) PRESSURE RANGE		SPRING COLOR	SPRING PART NUMBER	SPRING WIRE DIAMETER		SPRING FREE LENGTH	
In. w.c.	mbar			In.	mm	In.	mm
1 to 2.5 <sup>(1)(2)</sup>	2.5 to 6.2 <sup>(1)(2)</sup>	Orange	1B558527052	0.072	1.8	3.25	82.6
2.5 to 7 <sup>(1)</sup>	6.2 to 17 <sup>(1)</sup>	Red	1B653827052	0.085	2.2	3.63	92.2
7 to 16	17 to 40	Unpainted	1B653927022	0.105	2.7	3.75	95.2
0.5 to 1.2 psig	34 to 83	Yellow	1B537027052	0.114	2.9	4.31	109
1.2 to 2.5 psig	83 to 172	Green	1B537127022	0.156	4.0	4.06	103
2.5 to 4.5 psig	0.17 to 0.31 bar	Light blue	1B537227022	0.187	4.8	3.94	100
4.5 to 7 psig	0.31 to 0.48 bar	Black	1B537327052	0.218	5.5	3.98	101

1. To achieve the published outlet pressure range the spring case must be installed pointing down.  
 2. Do not use Fluorocarbon (FKM) diaphragm with this spring at diaphragm temperatures lower than 60°F / 16°C.

**Table 4. Trim Materials**

BODY AND SPRING CASE	DIAPHRAGM HEAD	LEVER ASSEMBLY	GUIDE INSERT	TRIM OPTION CODE	DIAPHRAGM MATERIAL <sup>(1)</sup>	DISK AND O-RING MATERIAL	OPERATING TEMPERATURE RANGE <sup>(2)(3)</sup>	OPERATING OUTLET PRESSURE <sup>(1)</sup>
Gray cast iron, WCC Carbon steel, LCC Carbon steel or CF8M/CF3M Stainless steel	304 Stainless steel	302 Stainless steel	316 Stainless steel	Standard	Nitrile (NBR)	Nitrile (NBR)	-40 to 180°F / -40 to 82°C	35 psi / 2.4 bar
				EE	EPDM	EPDM	-20 to 225°F / -29 to 107°C	
				FDA <sup>(4)</sup>				
				VV	Fluorocarbon (FKM)	Fluorocarbon (FKM)	40 to 300°F / 4 to 149°C	
				TN	Fluorinated Ethylene Propylene (FEP)	Nitrile (NBR)	-20 to 180°F / -29 to 82°C	10 psi / 0.7 bar
				TV	Fluorinated Ethylene Propylene (FEP)	Fluorocarbon (FKM)	40 to 180°F / 4 to 82°C	
TK	Fluorinated Ethylene Propylene (FEP)	Perfluoroelastomer (FFKM)	0 to 180°F / -18 to 82°C					
				TE	Fluorinated Ethylene Propylene (FEP)	EPDM	-20 to 180°F / -29 to 82°C	

1. Types T205H and T205HM are available with Nitrile (NBR) diaphragm only, operating temperature range of -20 to 180°F / -29 to 82°C and operating outlet pressure of 150 psi / 10.3 bar.  
 2. Gray cast iron and WCC Carbon steel bodies are limited to -20 to 300°F / -29 to 149°C.  
 3. Special low temperature construction for process temperatures between -76 to 180°F / -60 to 82°C are available by request. The low temperature construction passed Emerson laboratory testing for lockup and external leakage down to -76°F / -60°C.  
 4. EPDM option available with FDA/USP Class VI approved/ADI-free elastomers (wetted components only).

# T205 Series

**Table 5. Flow Coefficients**

TYPE	ORIFICE SIZE		FLOW COEFFICIENTS (WIDE-OPEN)		C <sub>1</sub>
	In.	mm	C <sub>g</sub>	C <sub>v</sub>	
T205, T205H, T205M and T205HM	1/8	3.2	12	0.36	33.3
	1/4	6.4	47	1.40	33.1
	3/8	9.5	101	2.96	34.1
	1/2	13	174	5.20	33.4
	9/16	14	205	6.20	33.1

**Table 6. Correction Factors (For converting Air Flow Rates to Other Gas Flow Rates)<sup>(1)</sup>**

BLANKET GAS	SPECIFIC GRAVITY	CORRECTION FACTOR
Natural Gas	0.60	1.291
Nitrogen	0.97	1.015
Dry CO <sub>2</sub>	1.52	0.811

1. For gases of other specific gravities, use equation below.  
 Correction Factor =  $\frac{1.00}{\sqrt{SG}}$

## Installation

The regulator may be installed in any position as long as the flow through the body is in the direction indicated by the arrow on the body when using a T205 Series regulator. To achieve the published capacities at low setpoint, the spring case barrel should be installed pointed down as shown in Figures 2 and 3. For complete actuator drainage, the regulator should be installed as shown in Figure 4.

The diaphragm casing may be rotated in order to obtain desired positioning. The Type T205M or T205HM requires a downstream control line. The control line should be installed sloping downward toward the tank to prevent condensation buildup and avoid low points (or traps) that could catch liquid. The sensing line must enter the tank above the liquid level at a point that senses the vapor space pressure and is free from turbulence associated with tank nozzles or vents.

## Overpressure Protection

The T205 Series regulators have an outlet pressure rating lower than or equal their inlet pressure rating. If actual inlet pressure can exceed the outlet pressure rating, outlet overpressure protection is necessary.

Refer to the Capacity Information section and the relief sizing coefficients in Table 5 to determine the required relief valve capacity.

## Universal NACE Compliance

Optional materials are available for applications handling sour gases. These constructions comply with the recommendations of National Association of Corrosion Engineers (NACE) sour service standards.

The manufacturing processes and materials used by Emerson Process Management Regulator Technologies, Inc. assure that all products specified for sour gas service comply with the chemical, physical and metallurgical requirements of NACE MR0175-2002. Customers have the responsibility to specify correct materials. Environmental limitations may apply and shall be determined by the user.

## Capacity Information

Capacity tables are based on 1.0 specific gravity air. If other blanketing gas is used, convert the tabular values as follows. For blanketing (pad) gases other than air, multiply the given air flow rate by the correction factors in Table 6. For gases of other specific gravities, divide the given air flow rate by the square root of the appropriate specific gravity.

$$Q = \sqrt{\frac{520}{GT}} C_g P_1 \text{SIN} \left[ \frac{3417}{C_1} \sqrt{\frac{\Delta P}{P_1}} \right] \text{DEG}$$

where,

- Q = gas flow rate, SCFH
- G = specific gravity of the gas
- T = absolute temperature of gas at inlet, °Rankine
- C<sub>g</sub> = gas sizing coefficient
- P<sub>1</sub> = absolute inlet pressure, psia
- C<sub>1</sub> = C<sub>g</sub>/C<sub>v</sub>, flow coefficient
- ΔP = pressure drop across the regulator, psi

**Table 7. Flow Capacities of Types T205 and T205H with 3/4 in. / DN 20 Body Size<sup>(1)</sup>**

SPRING RANGE AND COLOR	OUTLET PRESSURE SETTING	OFFSET FROM SETPOINT	INLET PRESSURE		CAPACITIES IN SCFH / Nm <sup>3</sup> /h OF AIR									
					Orifice Size, In. / mm									
			psig	bar	1/8 / 3.2		1/4 / 6.4		3/8 / 9.5		1/2 / 13		9/16 / 14	
					SCFH	Nm <sup>3</sup> /h	SCFH	Nm <sup>3</sup> /h	SCFH	Nm <sup>3</sup> /h	SCFH	Nm <sup>3</sup> /h	SCFH	Nm <sup>3</sup> /h
1 to 2.5 in. w.c. / 2.5 to 6.2 mbar  Orange	1 in. w.c. / 2.5 mbar	-1 to 2 in. w.c. / -2.5 to 5.0 mbar	1	0.07	74	1.98	215	5.76	315	8.44	584	15.7	565	15.1
			2	0.14	117	3.14	380	10.2	612	16.4	666	17.8	778	20.9
			5	0.34	196	5.25	604	16.2	767	20.6	973	26.1	1041	27.9
			10	0.69	280	7.50	813	21.8	966	25.9	1301	34.9	1325	35.5
			15	1.0	346	9.27	1019	27.3	1222	32.7	1531	41.0	1146	30.7
			20	1.4	411	11.0	1190	31.9	1352	36.2	1707	45.7	1173	31.4
			30	2.1	533	14.3	1487	39.9	1575	42.2	1518	40.7		
			40	2.8	655	17.6	1809	48.5	1236	33.1				
			60	4.1	877	23.5	1904	51.0	1190	31.9				
			80	5.5	1105	29.6	1586	42.5						
			100	6.9	1352	36.2	1618	43.4						
			125	8.6	1647	44.1	1637	43.9						
			150	10.3	1936	51.9								
			175	12.1	1866	50.0								
	200	13.8	1452	38.9										
	2 in. w.c. / 5.0 mbar	-1 to 2 in. w.c. / -2.5 to 5.0 mbar	1	0.07	70	1.88	212	5.68	279	7.48	442	11.8	466	12.5
			2	0.14	108	2.89	360	9.65	569	15.2	599	16.1	700	18.8
			5	0.34	188	5.04	567	15.2	720	19.3	885	23.7	977	26.2
			10	0.69	282	7.56	808	21.7	919	24.6	1250	33.5	1259	33.7
			15	1.0	353	9.46	971	26.0	1108	29.7	1502	40.3	1145	30.7
20			1.4	415	11.1	1165	31.2	1334	35.8	1217	32.6	1047	28.1	
30			2.1	540	14.5	1503	40.3	1529	41.0	1204	32.3			
40			2.8	656	17.6	1662	44.5	1209	32.4					
60			4.1	875	23.4	1885	50.5	2346	62.9					
80			5.5	1129	30.3	1292	34.6							
100			6.9	1367	36.6	1568	42.0							
125			8.6	1662	44.5	1564	41.9							
150			10.3	1857	49.8									
175			12.1	1817	48.7									
200			13.8	1472	39.4									
2.5 to 7 in. w.c. / 6.2 to 17 mbar  Red			2.5 in. w.c. / 6.2 mbar	-1 to 2 in. w.c. / -2.5 to 5.0 mbar	1	0.07	69	1.85	124	3.32	236	6.32	318	8.52
	2	0.14			95	2.55	178	4.77	429	11.5	495	13.3	473	12.7
	5	0.34			150	4.02	321	8.60	531	14.2	730	19.6	777	20.8
	10	0.69			265	7.10	483	12.9	761	20.4	1014	27.2	1121	30.0
	15	1.0			347	9.30	611	16.4	953	25.5	1272	34.1	1116	29.9
	20	1.4			409	11.0	765	20.5	1229	32.9	1557	41.7	1143	30.6
	30	2.1			532	14.3	1764	47.3	1411	37.8	1019	27.3	1131	30.3
	40	2.8			653	17.5	1328	35.6	1438	38.5	972	26.0		
	60	4.1			831	22.3	1768	47.4	2170	58.2				
	80	5.5			1045	28.0	1672	44.8	1435	38.5				
	100	6.9			1265	33.9	2644	70.9						
	125	8.6			1524	40.8	1338	35.9						
	150	10.3			1567	42.0	1509	40.4						
	175	12.1			1747	46.8	1553	41.6						
	200	13.8	1431	38.4										
	4 in. w.c. / 10 mbar	-1 to 2 in. w.c. / -2.5 to 5.0 mbar	1	0.07	66	1.77	115	3.08	161	4.31	266	7.13	264	7.08
			2	0.14	95	2.55	196	5.25	368	9.86	447	12.0	424	11.4
			5	0.34	149	3.99	366	9.81	488	13.1	620	16.6	698	18.7
			10	0.69	205	5.49	517	13.9	706	18.9	976	26.2	1175	31.5
			15	1.0	287	7.69	694	18.6	908	24.3	1209	32.4	931	25.0
20			1.4	356	9.54	853	22.9	1090	29.2	1482	39.7	1049	28.1	
30			2.1	504	13.5	1655	44.4	1380	37.0	1794	48.1	1035	27.7	

Shaded areas indicate where maximum operating inlet pressure for a given orifice size is exceeded.  
1. Use 3/4 in. body capacities for flanged 3/4 x 1 in. construction.

- continued -

# T205 Series

**Table 7. Flow Capacities of Types T205 and T205H with 3/4 in. / DN 20 Body Size (continued)<sup>(1)</sup>**

SPRING RANGE AND COLOR	OUTLET PRESSURE SETTING	OFFSET FROM SETPOINT	INLET PRESSURE		CAPACITIES IN SCFH / Nm <sup>3</sup> /h OF AIR									
					Orifice Size, In. / mm									
					1/8 / 3.2		1/4 / 6.4		3/8 / 9.5		1/2 / 13		9/16 / 14	
					psig	bar	SCFH	Nm <sup>3</sup> /h	SCFH	Nm <sup>3</sup> /h	SCFH	Nm <sup>3</sup> /h	SCFH	Nm <sup>3</sup> /h
2.5 to 7 in. w.c. / 6.2 to 17 mbar  Red	4 in. w.c. / 10 mbar	-1 to 2 in. w.c. / -2.5 to 5.0 mbar	40	2.8	643	17.2	1448	38.8	1474	39.5	1570	42.1		
			60	4.1	861	23.1	1713	45.9	1434	38.4				
			80	5.5	1095	29.3	1747	46.8	1389	37.2				
			100	6.9	1249	33.5	2673	71.6						
			125	8.6	1503	40.3	1596	42.8						
			150	10.3	1433	38.4	1563	41.9						
			175	12.1	1725	46.2	1628	43.6						
	200	13.8	1545	41.4										
	1	0.07	71	1.90	137	3.67	253	6.78	332	8.90	333	8.92		
	2	0.14	99	2.65	280	7.50	495	13.3	613	16.4	562	15.1		
	5	0.34	179	4.80	500	13.4	647	17.3	916	24.5	957	25.6		
	10	0.69	268	7.18	723	19.4	938	25.1	1299	34.8	1362	36.5		
	15	1.0	351	9.41	894	24.0	1147	30.7	1569	42.0	1422	38.1		
	20	1.4	416	11.1	1058	28.4	1354	36.3	1590	42.6	1463	39.2		
	30	2.1	539	14.4	1545	41.4	1483	39.7	2100	56.3	1482	39.7		
	40	2.8	644	17.3	1689	45.3	2077	55.7	1726	46.3				
	60	4.1	882	23.6	1855	49.7	2241	60.1						
	80	5.5	1134	30.4	2704	72.5	2442	65.4						
	100	6.9	1372	36.8	2745	73.6								
	125	8.6	1679	45.0	1729	46.3								
150	10.3	1926	51.6	1619	43.4									
175	12.1	1672	44.8	1720	46.1									
200	13.8	1598	42.8											
7 to 16 in. w.c. / 17 to 40 mbar  Unpainted	8 in. w.c. / 20 mbar	-2 to 2 in. w.c. / -5.0 to 5.0 mbar	1	0.07	62	1.66	146	3.91	192	5.15	233	6.24	314	8.42
			2	0.14	96	2.57	220	5.90	361	9.67	473	12.7	503	13.5
			5	0.34	164	4.40	428	11.5	555	14.9	831	22.3	861	23.1
			8	0.55	200	5.36	537	14.4	735	19.7	1029	27.6	1107	29.7
			20	1.4	390	10.5	980	26.3	1241	33.3	1647	44.1	1550	41.5
			35	2.4	579	15.5	1491	40.0	1521	40.8	1552	41.6	1675	44.9
			60	4.1	850	22.8	1698	45.5	2227	59.7	2629	70.5	3264	87.5
			75	5.2	1029	27.6	1923	51.5	2188	58.6	2633	70.6	3411	91.4
			100	6.9	1318	35.3	2699	72.3	2077	55.7	2277	61.0	2872	77.0
			125	8.6	1602	42.9	1635	43.8	3029	81.2	2155	57.8		
			150	10.3	1862	49.9	1645	44.1	1600	42.9				
			175	12.1	1820	48.8	1678	45.0	1030	27.6				
			200	13.8	1462	39.2	1806	48.4	1160	31.1				
	1	0.07	83	2.22	105	2.81	213	5.71	246	6.59	223	5.98		
	2	0.14	92	2.47	242	6.49	354	9.49	418	11.2	468	12.5		
	5	0.34	173	4.64	433	11.6	573	15.4	796	21.3	859	23.0		
	8	0.55	191	5.12	562	15.1	720	19.3	1031	27.6	1145	30.7		
	20	1.4	387	10.4	979	26.2	1228	32.9	1727	46.3	1545	41.4		
	35	2.4	583	15.6	1432	38.4	1517	40.7	1769	47.4	2541	68.1		
	60	4.1	872	23.4	1783	47.8	2294	61.5	2538	68.0	3339	89.5		
75	5.2	1013	27.1	1996	53.5	2156	57.8	2669	71.5	3452	92.5			
100	6.9	1288	34.5	2645	70.9	2123	56.9	2387	64.0	2779	74.5			
125	8.6	1565	41.9	1732	46.4	3066	82.2	2314	62.0					
150	10.3	1833	49.1	1900	50.9	1851	49.6							
175	12.1	1776	47.6	1887	50.6	1396	37.4							
200	13.8	2498	66.9	2010	53.9	1387	37.2							

- Shaded areas indicate where maximum operating inlet pressure for a given orifice size is exceeded.  
 1. Use 3/4 in. body capacities for flanged 3/4 x 1 in. construction.

- continued -



**Table 7. Flow Capacities of Types T205 and T205H with 3/4 in. / DN 20 Body Size (continued)<sup>(1)</sup>**

SPRING RANGE AND COLOR	OUTLET PRESSURE SETTING	OFFSET FROM SETPOINT	INLET PRESSURE		CAPACITIES IN SCFH / Nm <sup>3</sup> /h OF AIR									
					Orifice Size, In. / mm									
					1/8 / 3.2		1/4 / 6.4		3/8 / 9.5		1/2 / 13		9/16 / 14	
			psig	bar	SCFH	Nm <sup>3</sup> /h	SCFH	Nm <sup>3</sup> /h	SCFH	Nm <sup>3</sup> /h	SCFH	Nm <sup>3</sup> /h	SCFH	Nm <sup>3</sup> /h
7 to 16 in. w.c. / 17 to 40 mbar  Unpainted	16 in. w.c. / 40 mbar	20% Gauge	1	0.07			110	2.95	197	5.28	222	5.95	236	6.32
			2	0.14	96	2.57	234	6.27	375	10.0	470	12.6	524	14.0
			5	0.34	178	4.77	467	12.5	629	16.9	912	24.4	926	24.8
			8	0.55	208	5.57	587	15.7	799	21.4	1155	31.0	1217	32.6
			20	1.4	377	10.1	1050	28.1	1315	35.2	1653	44.3	1752	47.0
			35	2.4	584	15.7	1593	42.7	1683	45.1	1857	49.8	2814	75.4
			60	4.1	849	22.8	1953	52.3	2320	62.2	2983	79.9	3404	91.2
			75	5.2	1052	28.2	2647	70.9	2218	59.4	2805	75.2	3611	96.8
			100	6.9	1322	35.4	2620	70.2	2139	57.3	2816	75.5	2967	79.5
			125	8.6	1609	43.1	2845	76.2	3162	84.7	2590	69.4		
			150	10.3	1890	50.7	2117	56.7	3365	90.2				
			175	12.1	1901	50.9	2134	57.2	3319	88.9				
200	13.8	2459	65.9	2496	66.9	3469	93.0							
0.5 to 1.2 psig / 34 to 83 mbar  Yellow	0.58 psig / 40 mbar	20% Gauge	2	0.14	115	3.08	216	5.79	357	9.57	459	12.3	476	12.8
			6	0.41	174	4.66	448	12.0	607	16.3	909	24.4	909	24.4
			10	0.69	235	6.30	623	16.7	851	22.8	1246	33.4	1373	36.8
			30	2.1	512	13.7	1277	34.2	1648	44.2	1484	39.8	2029	54.4
			45	3.1	666	17.8	1957	52.4	1571	42.1	2117	56.7	2885	77.3
			60	4.1	844	22.6	1920	51.5	2576	69.0	1979	53.0	3381	90.6
			80	5.5	1087	29.1	2719	72.9	2253	60.4	2517	67.5	2910	78.0
			100	6.9	1318	35.3	2734	73.3	2177	58.3	2740	73.4	2979	79.8
			125	8.6	1590	42.6	1925	51.6	2685	72.0	2155	57.8	3075	82.4
			150	10.3	1875	50.2	2012	53.9	3031	81.2	2144	57.5		
	175	12.1	1909	51.2	1918	51.4	3022	81.0						
	200	13.8	2517	67.5	1982	53.1	2586	69.3						
	1 psi / 69 mbar	20% Gauge	2	0.14	108	2.89	265	7.10	401	10.7	521	14.0	528	14.2
			6	0.41	191	5.12	537	14.4	755	20.2	1083	29.0	1096	29.4
			10	0.69	259	6.94	761	20.4	991	26.6	1419	38.0	1672	44.8
			30	2.1	544	14.6	1478	39.6	1802	48.3	2203	59.0	2236	59.9
			60	4.1	898	24.1	2241	60.1	2438	65.3	2675	71.7	3592	96.3
			80	5.5	1139	30.5	2858	76.6	2348	62.9	2986	80.0	3869	104
100			6.9	1383	37.1	2908	77.9	2279	61.1	3155	84.6	3273	87.7	
125			8.6	1667	44.7	2193	58.8	3364	90.2	2937	78.7	3409	91.4	
150			10.3	1976	53.0	3339	89.5	3608	96.7	2912	78.0			
175			12.1	2259	60.5	3769	101	3664	98.2					
200	13.8	2562	68.7	2634	70.6	3748	100							
1.2 to 2.5 psig / 83 to 172 mbar  Green	20% Gauge	4	0.28	120	3.22	264	7.08	406	10.9	572	15.3	578	15.5	
		8	0.55	164	4.40	431	11.6	580	15.5	883	23.7	905	24.3	
		12	0.83	212	5.68	552	14.8	754	20.2	1134	30.4	1146	30.7	
		30	2.1	439	11.8	1074	28.8	1442	38.6	1558	41.8	1978	53.0	
		60	4.1	765	20.5	1815	48.6	2373	63.6	3199	85.7	3221	86.3	
		80	5.5	986	26.4	1997	53.5	2349	63.0	3243	86.9	3570	95.7	
		100	6.9	1235	33.1	2788	74.7	2271	60.9	2644	70.9	3088	82.8	
		125	8.6	1462	39.2	3128	83.8	2207	59.1	2973	79.7	3341	89.5	
		150	10.3	1627	43.6	3452	92.5	3295	88.3	2729	73.1	3401	91.1	
		175	12.1	1813	48.6	4092	110	3465	92.9	2680	71.8	3495	93.7	
200	13.8	2501	67.0	3873	104	3538	94.8	2782	74.6	3445	92.3			

- Black areas indicate where desired flow capacity is not obtainable for a given inlet pressure.  
 - Shaded areas indicate where maximum operating inlet pressure for a given orifice size is exceeded.  
 1. Use 3/4 in. body capacities for flanged 3/4 x 1 in. construction.

- continued -

# T205 Series

Table 7. Flow Capacities of Types T205 and T205H with 3/4 in. / DN 20 Body Size (continued)<sup>(1)</sup>

SPRING RANGE AND COLOR	OUTLET PRESSURE SETTING	OFFSET FROM SETPOINT	INLET PRESSURE		CAPACITIES IN SCFH / Nm <sup>3</sup> /h OF AIR									
					Orifice Size, In. / mm									
			psig	bar	1/8 / 3.2		1/4 / 6.4		3/8 / 9.5		1/2 / 13		9/16 / 14	
					SCFH	Nm <sup>3</sup> /h	SCFH	Nm <sup>3</sup> /h	SCFH	Nm <sup>3</sup> /h	SCFH	Nm <sup>3</sup> /h	SCFH	Nm <sup>3</sup> /h
1.2 to 2.5 psig / 83 to 172 mbar  Green	2.5 psi / 172 mbar	20% Gauge	6	0.41	159	4.26	465	12.5	677	18.1	943	25.3	1015	27.2
			10	0.69	240	6.43	672	18.0	954	25.6	1363	36.5	1431	38.4
			30	2.1	497	13.3	1441	38.6	2073	55.6	2607	69.9	1943	52.1
			60	4.1	864	23.2	2288	61.3	2697	72.3	3216	86.2	3980	107
			80	5.5	1143	30.6	3008	80.6	3224	86.4	3821	102	4444	119
			100	6.9	1354	36.3	3222	86.3	3178	85.2	4208	113	4698	126
			125	8.6	1646	44.1	3517	94.3	3539	94.8	3893	104	4118	110
			150	10.3	1906	51.1	3893	104	3961	106	3760	101	4332	116
			175	12.1	2235	59.9	4555	122	3974	107	3884	104	4449	119
			200	13.8	2528	67.8	4627	124	4158	111	3511	94.1	4515	121
2.5 to 4.5 psig / 0.17 to 0.31 bar  Light blue	2.5 psi / 0.17 bar	20% Gauge	4	0.28	128	3.43	209	5.60	335	8.98	466	12.5	487	13.1
			8	0.55	210	5.63	416	11.1	564	15.1	832	22.3	873	23.4
			12	0.83	277	7.42	539	14.4	749	20.1	1080	28.9	1167	31.3
			30	2.1	518	13.9	1022	27.4	1777	47.6	1766	47.3	1891	50.7
			60	4.1	897	24.0	1804	48.3	2474	66.3	2776	74.4	3488	93.5
			80	5.5	1124	30.1	2084	55.9	2848	76.3	3774	101	4004	107
			100	6.9	1364	36.6	2763	74.0	2907	77.9	3837	103	3626	97.2
			125	8.6	1603	43.0	3237	86.8	3392	90.9	3810	102	3847	103
			150	10.3	1951	52.3	3504	93.9	3765	101	3898	104	3933	105
			175	12.1	2208	59.2	3917	105	3874	104	3746	100	4138	111
	200	13.8	2493	66.8	3965	106	4060	109	3520	94.3	4138	111		
	4.5 psi / 0.31 bar	20% Gauge	8	0.55	194	5.20	416	11.1	714	19.1	992	26.6	1005	26.9
			12	0.83	283	7.58	658	17.6	908	24.3	1357	36.4	1511	40.5
			30	2.1	520	13.9	1290	34.6	1830	49.0	2593	69.5	2610	69.9
			60	4.1	909	24.4	2201	59.0	3099	83.1	3732	100	4352	117
			80	5.5	1143	30.6	2727	73.1	3470	93.0	3865	104	4886	131
			100	6.9	1300	34.8	3277	87.8	3393	90.9	4575	123	5315	142
			125	8.6	1673	44.8	3690	98.9	3862	104	5056	136	5623	151
			150	10.3	1950	52.3	4109	110	4346	116	5459	146	5495	147
			175	12.1	2032	54.5	4462	120	4569	122	5313	142	5459	146
200			13.8	2174	58.3	5005	134	4757	127	4826	129	5587	150	
4.5 to 7 psig / 0.31 to 0.48 bar  Black	4.5 psi / 0.31 bar	20% Gauge	9	0.62	188	5.04	407	10.9	566	15.2	791	21.2	885	23.7
			12	0.83	205	5.49	516	13.8	693	18.6	829	22.2	1109	29.7
			30	2.1	438	11.7	1012	27.1	1570	42.1	1891	50.7	2136	57.2
			60	4.1	753	20.2	1745	46.8	2403	64.4	2785	74.6	3574	95.8
			80	5.5	930	24.9	2161	57.9	2974	79.7	3727	99.9	4195	112
			100	6.9	1177	31.5	2533	67.9	3099	83.1	4542	122	4628	124
			125	8.6	1390	37.3	3168	84.9	3546	95.0	4202	113	4695	126
			150	10.3	1658	44.4	3680	98.6	4032	108	5014	134	4836	130
			175	12.1	1871	50.1	3988	107	4236	114	5155	138	5185	139
			200	13.8	2254	60.4	4232	113	4570	122	4663	125	5029	135
	7 psi / 0.48 bar	20% Gauge	9	0.62	173	4.64	402	10.8	618	16.6	843	22.6	563	15.1
			12	0.83	222	5.95	573	15.4	777	20.8	1177	31.5	830	22.2
			30	2.1	490	13.1	1239	33.2	2040	54.7	2328	62.4	1830	49.0
			60	4.1	849	22.8	2156	57.8	2833	75.9	3687	98.8	4379	117
			80	5.5	1065	28.5	2658	71.2	3680	98.6	4649	125	5197	139
			100	6.9	1319	35.3	3308	88.7	3952	106	4998	134	5791	155
			125	8.6	1582	42.4	3836	103	4290	115	5945	159	6199	166
			150	10.3	1858	49.8	4240	114	4756	127	6269	168	6350	170
			175	12.1	2180	58.4	4688	126	5117	137	5788	155	6358	170
			200	13.8	2473	66.3	5153	138	5382	144	6439	173	6514	175

1. Use 3/4 in. body capacities for flanged 3/4 x 1 in. construction.

**Table 8. Flow Capacities of Types T205 and T205H with 1 in. / DN 25 Body Size**

SPRING RANGE AND COLOR	OUTLET PRESSURE SETTING	OFFSET FROM SETPOINT	INLET PRESSURE		CAPACITIES IN SCFH / Nm <sup>3</sup> /h OF AIR									
					Orifice Size, In. / mm									
					1/8 / 3.2		1/4 / 6.4		3/8 / 9.5		1/2 / 13		9/16 / 14	
					psig	bar	SCFH	Nm <sup>3</sup> /h	SCFH	Nm <sup>3</sup> /h	SCFH	Nm <sup>3</sup> /h	SCFH	Nm <sup>3</sup> /h
1 to 2.5 in. w.c. / 2.5 to 6.2 mbar  Orange	1 in. w.c. / 2.5 mbar	-1 to 2 in. w.c. / -2.5 to 5.0 mbar	1	0.07	88	2.36	334	8.95	611	16.4	950	25.5	1101	29.5
			2	0.14	129	3.46	479	12.8	837	22.4	1258	33.7	1418	38.0
			5	0.34	211	5.65	756	20.3	1314	35.2	2067	55.4	2385	63.9
			10	0.69	294	7.88	1069	28.6	1958	52.5	3158	84.6	1934	51.8
			15	1.0	349	9.35	1318	35.3	2475	66.3	2486	66.6	1934	51.8
			20	1.4	414	11.1	1587	42.5	2332	62.5	1789	47.9	1836	49.2
			30	2.1	538	14.4	2057	55.1	2104	56.4	1919	51.4		
			40	2.8	668	17.9	1996	53.5	1917	51.4				
			60	4.1	912	24.4	1923	51.5						
			80	5.5	1126	30.2	1640	44.0						
	100	6.9	1373	36.8	1759	47.1								
	125	8.6	1661	44.5										
	150	10.3	1941	52.0										
	175	12.1	2260	60.6										
	200	13.8	2552	68.4										
	2 in. w.c. / 5.0 mbar	-1 to 2 in. w.c. / -2.5 to 5.0 mbar	1	0.07	95	2.55	332	8.90	599	16.1	890	23.9	1065	28.5
			2	0.14	118	3.16	342	9.17	818	21.9	1247	33.4	1381	37.0
			5	0.34	204	5.47	688	18.4	1314	35.2	2094	56.1	2400	64.3
			10	0.69	298	7.99	1036	27.8	1945	52.1	2806	75.2	2655	71.2
			15	1.0	368	9.86	1319	35.3	2659	71.3	2136	57.2	1931	51.8
20			1.4	411	11.0	1569	42.0	2620	70.2	1875	50.2	1736	46.5	
30			2.1	538	14.4	2013	53.9	2060	55.2	1801	48.3			
40			2.8	676	18.1	1854	49.7	1834	49.2					
60			4.1	906	24.3	1696	45.5							
80			5.5	1139	30.5	1722	46.1							
100			6.9	1383	37.1	1631	43.7							
125			8.6	1677	44.9									
150			10.3	1977	53.0									
175			12.1	2284	61.2									
200	13.8	2544	68.2											
2.5 to 7 in. w.c. / 6.2 to 17 mbar  Red	2.5 in. w.c. / 6.2 mbar	-1 to 2 in. w.c. / -2.5 to 5.0 mbar	1	0.07	96	2.57	207	5.55	385	10.3	521	14.0	512	13.7
			2	0.14	119	3.19	334	8.95	519	13.9	976	26.2	823	22.1
			5	0.34	181	4.85	555	14.9	1246	33.4	1988	53.3	2370	63.5
			10	0.69	280	7.50	991	26.6	1908	51.1	3132	83.9	2316	62.1
			15	1.0	352	9.43	1308	35.1	2435	65.3	2190	58.7	2028	54.4
			20	1.4	359	9.62	1530	41.0	2940	78.8	2094	56.1		
			30	2.1	539	14.4	2016	54.0	2277	61.0	1842	49.4		
			40	2.8	659	17.7	2232	59.8	2256	60.5	1862	49.9		
			60	4.1	896	24.0	1857	49.8	3013	80.7				
			80	5.5	1131	30.3	1655	44.4	2095	56.1				
	100	6.9	1237	33.2	1637	43.9								
	125	8.6	1572	42.1	1775	47.6								
	150	10.3	1875	50.2	1460	39.1								
	175	12.1	2232	59.8										
	200	13.8	2563	68.7										
	4 in. w.c. / 10 mbar	-1 to 2 in. w.c. / -2.5 to 5.0 mbar	1	0.07	101	2.71	222	5.95	308	8.25	368	9.86	422	11.3
			2	0.14	101	2.71	321	8.60	414	11.1	619	16.6	657	17.6
			5	0.34	204	5.47	441	11.8	1024	27.4	1940	52.0	2348	62.9
			10	0.69	290	7.77	838	22.5	1804	48.3	3184	85.3	3308	88.7
			15	1.0	353	9.46	1233	33.0	2453	65.7	3468	92.9	2597	69.6
20			1.4	418	11.2	1534	41.1	2878	77.1	2088	56.0			
30	2.1	534	14.3	2002	53.7	3923	105	1986	53.2					

Shaded areas indicate where maximum operating inlet pressure for a given orifice size is exceeded.

- continued -

# T205 Series

**Table 8. Flow Capacities of Types T205 and T205H with 1 in. / DN 25 Body Size (continued)**

SPRING RANGE AND COLOR	OUTLET PRESSURE SETTING	OFFSET FROM SETPOINT	INLET PRESSURE		CAPACITIES IN SCFH / Nm <sup>3</sup> /h OF AIR									
					Orifice Size, In. / mm									
					1/8 / 3.2		1/4 / 6.4		3/8 / 9.5		1/2 / 13		9/16 / 14	
					psig	bar	SCFH	Nm <sup>3</sup> /h	SCFH	Nm <sup>3</sup> /h	SCFH	Nm <sup>3</sup> /h	SCFH	Nm <sup>3</sup> /h
2.5 to 7 in. w.c. / 6.2 to 17 mbar  Red	4 in. w.c. / 10 mbar	-1 to 2 in. w.c. / -2.5 to 5.0 mbar	40	2.8	654	17.5	2503	67.1	4901	131	1881	50.4		
			60	4.1	854	22.9	1973	52.9	3933	105				
			80	5.5	1102	29.5	1796	48.1	2603	69.8				
			100	6.9	1371	36.7	1576	42.2						
			125	8.6	1668	44.7	1803	48.3						
			150	10.3	1930	51.7	1444	38.7						
			175	12.1	2140	57.4								
			200	13.8	2438	65.3								
	1	0.07	77	2.06	252	6.75	384	10.3	571	15.3	693	18.6		
	2	0.14	112	3.00	331	8.87	643	17.2	974	26.1	1137	30.5		
	5	0.34	197	5.28	601	16.1	1183	31.7	1971	52.8	2319	62.1		
	10	0.69	291	7.80	871	23.3	1834	49.2	3366	90.2	3706	99.3		
	15	1.0	349	9.35	1235	33.1	2403	64.4	2656	71.2	3881	104		
	20	1.4	418	11.2	1510	40.5	2903	77.8	2019	54.1				
	30	2.1	549	14.7	1994	53.4	2935	78.7	2039	54.6				
	40	2.8	648	17.4	2460	65.9	2229	59.7	1782	47.8				
	60	4.1	896	24.0	1978	53.0	2778	74.5						
	80	5.5	1125	30.2	1764	47.3	2172	58.2						
	100	6.9	1335	35.8	1682	45.1								
	125	8.6	1601	42.9	1815	48.6								
150	10.3	1902	51.0	1648	44.2									
175	12.1	2217	59.4											
200	13.8	2337	62.6											
7 to 16 in. w.c. / 17 to 40 mbar  Unpainted	8 in. w.c. / 20 mbar	-2 to 2 in. w.c. / -5.0 to 5.0 mbar	1	0.07	67	1.80	245	6.57	253	6.78	497	13.3	510	13.7
			2	0.14	113	3.03	290	7.77	463	12.4	652	17.5	782	21.0
			5	0.34	189	5.07	547	14.7	906	24.3	1474	39.5	2215	59.4
			8	0.55	250	6.70	665	17.8	1420	38.1	2761	74.0	3160	84.7
			20	1.4	337	9.03	1318	35.3	2674	71.7	2462	66.0	2171	58.2
			35	2.4	550	14.7	2225	59.6	4257	114	2330	62.4	1660	44.5
			60	4.1	885	23.7	2043	54.8	3769	101	2319	62.1	1409	37.8
			75	5.2	1088	29.2	1761	47.2	2895	77.6	1652	44.3	1395	37.4
			100	6.9	1370	36.7	1640	44.0	1961	52.6	1863	49.9	1044	28.0
			125	8.6	1667	44.7	1957	52.4	1831	49.1	895	24.0		
			150	10.3	1958	52.5	1560	41.8	1215	32.6				
			175	12.1	2210	59.2								
	200	13.8	2349	63.0										
	1	0.07	81	2.17	242	6.49	204	5.47	421	11.3	465	12.5		
	2	0.14	118	3.16	255	6.83	378	10.1	672	18.0	699	18.7		
	5	0.34	183	4.90	493	13.2	766	20.5	1249	33.5	1422	38.1		
	8	0.55	244	6.54	717	19.2	1313	35.2	2694	72.2	3105	83.2		
	20	1.4	395	10.6	1453	38.9	2381	63.8	2412	64.6	2362	63.3		
	35	2.4	617	16.5	2239	60.0	3775	101	2019	54.1	1809	48.5		
	60	4.1	895	24.0	2226	59.7	2986	80.0	1983	53.1	1533	41.1		
75	5.2	1078	28.9	1914	51.3	2663	71.4	1854	49.7	1494	40.0			
100	6.9	1375	36.8	1802	48.3	2041	54.7	1550	41.5	1179	31.6			
125	8.6	1651	44.2	2347	62.9	1274	34.1	1447	38.8					
150	10.3	1965	52.7	1717	46.0	1303	34.9							
175	12.1	2276	61.0											
200	13.8	2534	67.9											

Shaded areas indicate where maximum operating inlet pressure for a given orifice size is exceeded.

- continued -

**Table 8. Flow Capacities of Types T205 and T205H with 1 in. / DN 25 Body Size (continued)**

SPRING RANGE AND COLOR	OUTLET PRESSURE SETTING	OFFSET FROM SETPOINT	INLET PRESSURE		CAPACITIES IN SCFH / Nm <sup>3</sup> /h OF AIR									
					Orifice Size, In. / mm									
					1/8 / 3.2		1/4 / 6.4		3/8 / 9.5		1/2 / 13		9/16 / 14	
					psig	bar	SCFH	Nm <sup>3</sup> /h	SCFH	Nm <sup>3</sup> /h	SCFH	Nm <sup>3</sup> /h	SCFH	Nm <sup>3</sup> /h
7 to 16 in. w.c. / 17 to 40 mbar  Unpainted	16 in. w.c. / 40 mbar	20% Gauge	1	0.07	73	1.96	230	6.16	240	6.43	423	11.3	411	11.0
			2	0.14	98	2.63	275	7.37	368	9.86	699	18.7	824	22.1
			5	0.34	173	4.64	533	14.3	877	23.5	1280	34.3	1541	41.3
			8	0.55	247	6.62	716	19.2	1372	36.8	2543	68.2	2978	79.8
			20	1.4	400	10.7	1317	35.3	2679	71.8	5362	144	5845	157
			35	2.4	585	15.7	2158	57.8	3493	93.6	2312	62.0	2075	55.6
			60	4.1	869	23.3	2484	66.6	6906	185	2434	65.2	1892	50.7
			75	5.2	1044	28.0	2009	53.8	3030	81.2	2102	56.3	1710	45.8
			100	6.9	1363	36.5	2004	53.7	1785	47.8	1760	47.2	1737	46.6
			125	8.6	1672	44.8	2163	58.0	1630	43.7	1613	43.2		
			150	10.3	1871	50.1	2210	59.2	1707	45.7				
			175	12.1	2122	56.9								
200	13.8	2418	64.8											
0.5 to 1.2 psig / 34 to 83 mbar  Yellow	0.58 psig / 40 mbar	20% Gauge	2	0.14	104	2.79	302	8.09	417	11.2	589	15.8	656	17.6
			6	0.41	197	5.28	479	12.8	760	20.4	1330	35.6	1538	41.2
			10	0.69	253	6.78	737	19.8	1213	32.5	2380	63.8	3554	95.2
			30	2.1	516	13.8	1830	49.0	4049	109	2832	75.9	2199	58.9
			45	3.1	736	19.7	2397	64.2	3961	106	2790	74.8	2279	61.1
			60	4.1	881	23.6	3338	89.5	3909	105	2257	60.5	2075	55.6
			80	5.5	1114	29.9	3413	91.5	2499	67.0	1947	52.2	1749	46.9
			100	6.9	1363	36.5	3205	85.9	2354	63.1	1710	45.8	1566	42.0
			125	8.6	1588	42.6	2831	75.9	1235	33.1	1646	44.1	1737	46.6
			150	10.3	1749	46.9	2269	60.8	908	24.3	989	26.5		
	175	12.1	2056	55.1										
	200	13.8	2197	58.9										
	1 psi / 69 mbar	20% Gauge	2	0.14	108	2.89	272	7.29	393	10.5	631	16.9	739	19.8
			6	0.41	181	4.85	624	16.7	904	24.2	1531	41.0	1738	46.6
			10	0.69	270	7.24	869	23.3	1396	37.4	2430	65.1	3189	85.5
			30	2.1	494	13.2	1901	50.9	4067	109	4962	133	3260	87.4
			60	4.1	875	23.4	3318	88.9	3784	101	3392	90.9	2583	69.2
			80	5.5	1064	28.5	4327	116	3328	89.2	3169	84.9	2600	69.7
			100	6.9	1338	35.9	3765	101	3388	90.8	3061	82.0	2823	75.7
			125	8.6	1528	41.0	3269	87.6	3298	88.4	2525	67.7	2367	63.4
150			10.3	1678	45.0	3187	85.4			2500	67.0			
175			12.1	1890	50.7									
200	13.8	2187	58.6											
1.2 to 2.5 psig / 83 to 172 mbar  Green	1.2 psi / 83 mbar	20% Gauge	4	0.28	138	3.70	310	8.31	414	11.1	507	13.6	709	19.0
			8	0.55	207	5.55	492	13.2	656	17.6	984	26.4	1208	32.4
			12	0.83	253	6.78	662	17.7	864	23.2	1364	36.6	1706	45.7
			30	2.1	490	13.1	1312	35.2	1864	50.0	1986	53.2	7909	212
			60	4.1	808	21.7	2973	79.7	7021	188	3964	106	3821	102
			80	5.5	1054	28.2	4071	109	4694	126	3713	99.5	3124	83.7
			100	6.9	1289	34.5	5113	137	4053	109	3738	100	3542	94.9
			125	8.6	1608	43.1	4951	133	4454	119	3343	89.6	3354	89.9
			150	10.3	1804	48.3	4882	131	4791	128	3318	88.9	3381	90.6
			175	12.1	2036	54.6	2582	69.2	3878	104	3039	81.4	3854	103
			200	13.8	2135	57.2	2367	63.4	2799	75.0	2729	73.1	4006	107

Shaded areas indicate where maximum operating inlet pressure for a given orifice size is exceeded.

- continued -

# T205 Series

Table 8. Flow Capacities of Types T205 and T205H with 1 in. / DN 25 Body Size (continued)

SPRING RANGE AND COLOR	OUTLET PRESSURE SETTING	OFFSET FROM SETPOINT	INLET PRESSURE		CAPACITIES IN SCFH / Nm <sup>3</sup> /h OF AIR										
					Orifice Size, in. / mm										
			psig	bar	1/8 / 3.2		1/4 / 6.4		3/8 / 9.5		1/2 / 13		9/16 / 14		
					SCFH	Nm <sup>3</sup> /h	SCFH	Nm <sup>3</sup> /h	SCFH	Nm <sup>3</sup> /h	SCFH	Nm <sup>3</sup> /h	SCFH	Nm <sup>3</sup> /h	
1.2 to 2.5 psig / 83 to 172 mbar  Green	2.5 psi / 172 mbar	20% Gauge	6	0.41	187	5.0	494	13.2	786	21.1	1112	29.8	1195	32.0	
			10	0.69	270	7.2	734	19.7	1123	30.1	1597	42.8	1792	48.0	
			30	2.1	523	14.0	1414	37.9	2875	77.1	5879	157.6	7620	204.2	
			60	4.1	897	24.0	3159	84.7	6894	184.8	5840	157	5545	149	
			80	5.5	1158	31.0	4195	112.4	8711	186.9	5277	141	5169	139	
			100	6.9	1332	35.7	5256	140.9	4766	127.7	4826	129	5152	138	
			125	8.6	1590	42.6	6389	171.2	4874	130.6	4545	122	4978	133	
			150	10.3	1856	49.7	6353	170.3	6613	177	4630	124	4373	117	
			175	12.1	2175	58.3	6297	168.8	6634	178	4194	112	4257	114	
200	13.8	2386	63.9	6854	183.7	6117	164	4321	116	4459	120				
2.5 to 4.5 psig / 0.17 to 0.31 bar  Light blue	2.5 psi / 0.17 bar	20% Gauge	4	0.28	108	2.89	269	7.21	334	8.95	535	14.3	550	14.7	
			8	0.55	200	5.36	375	10.0	581	15.6	937	25.1	1034	27.7	
			12	0.83	244	6.54	514	13.8	784	21.0	1260	33.8	1421	38.1	
			30	2.1	452	12.1	1083	29.0	1579	42.3	2256	60.5	4054	109	
			60	4.1	782	21.0	2046	54.8	3578	95.9	11,836	317	12,955	347	
			80	5.5	1040	27.9	3044	81.6	8962	240	5769	155	5846	157	
			100	6.9	1205	32.3	4667	125	7249	194	5219	140	5078	136	
			125	8.6	1428	38.3	6395	171	5114	137	4895	131	5371	144	
			150	10.3	1819	48.7	7511	201	7377	198	5340	143	5291	142	
	175	12.1	2127	57.0	7230	194	7205	193	5277	141	5183	139			
	200	13.8	2198	58.9	7118	191	6708	180	5094	137	4415	118			
	4.5 to 7 psig / 0.31 to 0.48 bar  Black	4.5 psi / 0.31 bar	20% Gauge	8	0.55	174	4.7	472	12.6	721	19.3	1142	30.6	1174	31.5
				12	0.83	259	6.9	632	16.9	1025	27.5	1569	42.0	1678	45.0
				30	2.1	507	13.6	1309	35.1	2070	55.5	3345	89.6	4494	120
				60	4.1	910	24.4	2553	68.4	5189	139	11,261	302	13,488	361
				80	5.5	1048	28.1	3573	95.8	8714	234	15,292	410	17,613	472
				100	6.9	1329	35.6	4707	126.1	10,429	279	8158	219	8263	221
				125	8.6	1558	41.8	6177	165.5	12,919	346	7482	201	7714	207
150				10.3	1854	49.7	7387	198.0	8855	237	6896	185	7902	212	
175				12.1	2096	56.2	8569	229.6	86,460	2317	7401	198	7341	197	
200	13.8	2380	63.8	9791	262.4	8496	228	6937	186	7374	198				
4.5 to 7 psig / 0.31 to 0.48 bar  Black	7 psi / 0.48 bar	20% Gauge	9	0.62	178	4.8	383	10.3	595	15.9	874	23.4	988	26.5	
			12	0.83	230	6.2	498	13.3	766	20.5	1085	29.1	1242	33.3	
			30	2.1	433	11.6	963	25.8	1518	40.7	2234	59.9	2712	72.7	
			60	4.1	568	15.2	1773	47.5	3086	82.7	9206	247	11,377	305	
			80	5.5	835	22.4	2506	67.2	7112	190.6	14,046	376	16,558	444	
			100	6.9	1172	31.4	3328	89.2	10,062	269.7	10,634	285	20,116	539	
			125	8.6	1486	39.8	4809	128.9	12,529	335.8	8487	227	8479	227	
			150	10.3	1697	45.5	6744	180.7	11,766	315	8244	221	8656	232	
			175	12.1	2069	55.4	8494	227.6	9717	260	8031	215	8225	220	
	200	13.8	2182	58.5	9751	261.3	9382	251	7948	213	8603	231			
	7 psi / 0.48 bar	20% Gauge	9	0.62	150	4.0	412	11.0	644	17.3	896	24.0	1049	28.1	
			12	0.83	232	6.2	570	15.3	838	22.5	1271	34.1	1481	39.7	
			30	2.1	410	11.0	1274	34.1	1896	50.8	2853	76.5	3469	93.0	
			60	4.1	845	22.6	2231	59.8	3776	101.2	8706	233	10,971	294	
			80	5.5	992	26.6	3150	84.4	6662	178.5	14,248	382	16,431	440	
			100	6.9	1245	33.4	3789	101.5	9314	249.6	17,873	479	19,768	530	
			125	8.6	1590	42.6	5404	144.8	12,573	337.0	21,735	582	24,399	654	
			150	10.3	1910	51.2	6895	184.8	15,464	414	11,120	298	11,405	306	
175			12.1	1939	52.0	8098	217.0	18,033	483	11,618	311	11,410	306		
200	13.8	2394	64.2	9331	250.1	13,239	355	11,601	311	9264	248				

**Table 9. Flow Capacities of Types T205M and T205HM with 3/4 in. / DN 20 Body Size<sup>(1)</sup>**

SPRING RANGE AND COLOR	OUTLET PRESSURE SETTING	OFFSET FROM SETPOINT	INLET PRESSURE		CAPACITIES IN SCFH / Nm <sup>3</sup> /h OF AIR									
					Orifice Size, In. / mm									
					1/8 / 3.2		1/4 / 6.4		3/8 / 9.5		1/2 / 13		9/16 / 14	
					psig	bar	SCFH	Nm <sup>3</sup> /h	SCFH	Nm <sup>3</sup> /h	SCFH	Nm <sup>3</sup> /h	SCFH	Nm <sup>3</sup> /h
1 to 2.5 in. w.c. / 2.5 to 6.2 mbar  Orange	1 in. w.c. / 2.5 mbar	-1 to 2 in. w.c. / -2.5 to 5.0 mbar	1	0.07	76	2.04	283	7.58	462	12.4	641	17.2	723	19.4
			2	0.14	116	3.11	420	11.3	730	19.6	879	23.6	1328	35.6
			5	0.34	201	5.39	739	19.8	1113	29.8	1899	50.9	1940	52.0
			10	0.69	290	7.77	1113	29.8	1923	51.5	2535	67.9	2501	67.0
			15	1.0	349	9.35	1380	37.0	2042	54.7	2736	73.3	4808	129
			20	1.4	416	11.1	1652	44.3	3019	80.9	4913	132	4853	130
			30	2.1	538	14.4	2647	70.9	4078	109	6541	175		
			40	2.8	653	17.5	3560	95.4	3238	86.8				
			60	4.1	895	24.0	4083	109	7557	203				
			80	5.5	1142	30.6	4365	117						
			100	6.9	1403	37.6	5344	143						
			125	8.6	1719	46.1	6455	173						
	150	10.3	2018	54.1										
	175	12.1	2314	62.0										
	200	13.8	2640	70.8										
	2 in. w.c. / 5.0 mbar	-1 to 2 in. w.c. / -2.5 to 5.0 mbar	1	0.07	64	1.72	256	6.86	437	11.7	529	14.2	710	19.0
			2	0.14	113	3.03	431	11.6	634	17.0	689	18.5	1036	27.8
			5	0.34	198	5.31	705	18.9	1018	27.3	1452	38.9	1436	38.5
			10	0.69	287	7.69	1069	28.6	1368	36.7	2073	55.6	2280	61.1
			15	1.0	352	9.43	1332	35.7	1645	44.1	2501	67.0	3728	99.9
20			1.4	415	11.1	1595	42.7	2541	68.1	2858	76.6	3839	103	
30			2.1	534	14.3	2038	54.6	3560	95.4	3558	95.4			
40			2.8	651	17.4	2602	69.7	2888	77.4					
60			4.1	894	24.0	3367	90.2	4921	132					
80			5.5	1139	30.5	3291	88.2							
100			6.9	1396	37.4	5027	135							
125			8.6	1692	45.3	6484	174							
150			10.3	2012	53.9									
175			12.1	2272	60.9									
200	13.8	2625	70.4											
2.5 to 7 in. w.c. / 6.2 to 17 mbar  Red	2.5 in. w.c. / 6.2 mbar	-1 to 2 in. w.c. / -2.5 to 5.0 mbar	1	0.07	67	1.80	178	4.77	257	6.89	534	14.3	416	11.1
			2	0.14	99	2.65	275	7.37	300	8.04	381	10.2	558	15.0
			5	0.34	184	4.93	246	6.59	599	16.1	793	21.3	909	24.4
			10	0.69	267	7.16	622	16.7	782	21.0	1137	30.5	1205	32.3
			15	1.0	337	9.03	821	22.0	1062	28.5	1095	29.3	2216	59.4
			20	1.4	287	7.69	875	23.4	1315	35.2	1576	42.2	2324	62.3
			30	2.1	490	13.1	1287	34.5	1645	44.1	3249	87.1	1456	39.0
			40	2.8	640	17.2	1390	37.3	1586	42.5	5020	135		
			60	4.1	836	22.4	1534	41.1	2705	72.5				
			80	5.5	1038	27.8	1840	49.3	5445	146				
			100	6.9	1247	33.4	2419	64.8						
			125	8.6	1441	38.6	2153	57.7						
			150	10.3	1548	41.5	6672	179						
			175	12.1	1571	42.1	8890	238						
200	13.8	2121	56.8											

- Shaded areas indicate where maximum operating inlet pressure for a given orifice size is exceeded.  
 1. Use 3/4 in. body capacities for flanged 3/4 x 1 in. construction.

- continued -

# T205 Series

**Table 9. Flow Capacities of Types T205M and T205HM with 3/4 in. / DN 20 Body Size (continued)<sup>(1)</sup>**

SPRING RANGE AND COLOR	OUTLET PRESSURE SETTING	OFFSET FROM SETPOINT	INLET PRESSURE		CAPACITIES IN SCFH / Nm <sup>3</sup> /h OF AIR										
					Orifice Size, In / mm										
			psig	bar	1/8 / 3.2		1/4 / 6.4		3/8 / 9.5		1/2 / 13		9/16 / 14		
					SCFH	Nm <sup>3</sup> /h	SCFH	Nm <sup>3</sup> /h	SCFH	Nm <sup>3</sup> /h	SCFH	Nm <sup>3</sup> /h	SCFH	Nm <sup>3</sup> /h	
2.5 to 7 in. w.c. / 6.2 to 17 mbar  Red	4 in. w.c. / 10 mbar	-1 to 2 in. w.c. / -2.5 to 5.0 mbar	1	0.07	81	2.17	160	4.29	265	7.10	289	7.75	302	8.09	
			2	0.14	95	2.55	259	6.94	284	7.61	265	7.10	472	12.6	
			5	0.34	170	4.56	190	5.09	444	11.9	674	18.1	741	19.9	
			10	0.69	249	6.67	521	14.0	637	17.1	976	26.2	1057	28.3	
			15	1.0	311	8.33	698	18.7	928	24.9	1222	32.7	1286	34.5	
			20	1.4	212	5.68	770	20.6	995	26.7	1183	31.7	1546	41.4	
			30	2.1	455	12.2	1138	30.5	1424	38.2	1992	53.4	1428	38.3	
			40	2.8	565	15.1	1210	32.4	1457	39.0	3542	94.9			
			60	4.1	748	20.0	1516	40.6	1489	39.9					
			80	5.5	893	23.9	1548	41.5	2124	56.9					
			100	6.9	1048	28.1	1613	43.2							
			125	8.6	1249	33.5	1609	43.1							
	150	10.3	1402	37.6	3764	101									
	175	12.1	1761	47.2	3782	101									
	200	13.8	2191	58.7											
		7 in. w.c. / 17.4 mbar	-2 to 2 in. w.c. / -5.0 to 5.0 mbar	1	0.07	69	1.85	182	4.88	308	8.25	358	9.59	507	13.6
	2			0.14	104	2.79	297	7.96	500	13.4	448	12.0	765	20.5	
	5			0.34	189	5.07	390	10.5	681	18.3	1091	29.2	1143	30.6	
	10			0.69	279	7.48	809	21.7	1091	29.2	1576	42.2	1720	46.1	
	15			1.0	338	9.06	1054	28.2	1462	39.2	1823	48.9	2337	62.6	
20	1.4			366	9.81	1250	33.5	1806	48.4	2277	61.0	3029	81.2		
30	2.1			516	13.8	1663	44.6	2603	69.8	4708	126	3955	106		
40	2.8			641	17.2	2004	53.7	2562	68.7	5000	134				
60	4.1			903	24.2	2514	67.4	4409	118						
80	5.5			1136	30.4	2983	79.9	6144	165						
100	6.9			1376	36.9	3813	102								
125	8.6			1680	45.0	4612	124								
150	10.3	1967	52.7	6810	183										
175	12.1	2263	60.6	8191	220										
200	13.8	2565	68.7												
7 to 16 in. w.c. / 17 to 40 mbar  Unpainted	8 in. w.c. / 20 mbar	-2 to 2 in. w.c. / -5.0 to 5.0 mbar	1	0.07	60	1.61	188	5.04	230	6.16	314	8.42	295	7.91	
			2	0.14	100	2.68	269	7.21	363	9.73	276	7.40	458	12.3	
			5	0.34	177	4.74	309	8.28	554	14.8	874	23.4	942	25.2	
			8	0.55	234	6.27	550	14.7	726	19.5	1111	29.8	1186	31.8	
			20	1.4	239	6.41	1002	26.9	1327	35.6	1746	46.8	1861	49.9	
			35	2.4	397	10.6	1402	37.6	1973	52.9	3390	90.9	2965	79.5	
			60	4.1	854	22.9	1974	52.9	2333	62.5	4429	119	4359	117	
			75	5.2	999	26.8	2381	63.8	2827	75.8	4912	132	5398	145	
			100	6.9	1311	35.1	2644	70.9	5222	140	6067	163	5169	139	
			125	8.6	1477	39.6	3586	96.1	5536	148	5335	143			
			150	10.3	1754	47.0	3923	105	3915	105					
			175	12.1	2131	57.1	6103	164	5346	143					
	200	13.8	2330	62.4	6821	183	5039	135							
		12 in. w.c. / 30 mbar	20% Gauge	1	0.07			147	3.94	193	5.17	261	6.99	268	7.18
	2			0.14	97	2.60	264	7.08	364	9.76	260	6.97	521	14.0	
	5			0.34	172	4.61	275	7.37	553	14.8	894	24.0	950	25.5	
	8			0.55	225	6.03	517	13.9	725	19.4	1117	29.9	1191	31.9	
	20			1.4	241	6.46	1073	28.8	1438	38.5	1793	48.1	1897	50.8	
	35			2.4	372	9.97	1481	39.7	1837	49.2	2301	61.7	3528	94.6	
	60			4.1	837	22.4	2038	54.6	2701	72.4	4702	126	5023	135	
75	5.2			1028	27.6	2335	62.6	3159	84.7	5420	145	5045	135		

     - Black areas indicate where desired flow capacity is not obtainable for a given inlet pressure.  
     - Shaded areas indicate where maximum operating inlet pressure for a given orifice size is exceeded.  
 1. Use 3/4 in. body capacities for flanged 3/4 x 1 in. construction.

- continued -



**Table 9. Flow Capacities of Types T205M and T205HM with 3/4 in. / DN 20 Body Size (continued)<sup>(1)</sup>**

SPRING RANGE AND COLOR	OUTLET PRESSURE SETTING	OFFSET FROM SETPOINT	INLET PRESSURE		CAPACITIES IN SCFH / Nm <sup>3</sup> /h OF AIR												
					Orifice Size, In. / mm												
					1/8 / 3.2		1/4 / 6.4		3/8 / 9.5		1/2 / 13		9/16 / 14				
					psig	bar	SCFH	Nm <sup>3</sup> /h	SCFH	Nm <sup>3</sup> /h	SCFH	Nm <sup>3</sup> /h	SCFH	Nm <sup>3</sup> /h	SCFH	Nm <sup>3</sup> /h	
7 to 16 in. w.c. / 17 to 40 mbar Unpainted	12 in. w.c. / 30 mbar	20% Gauge	100	6.9	1307	35.0	2847	76.3	4232	113	5979	160	5617	151			
			125	8.6	1503	40.3	3796	102	6164	165	4959	133					
			150	10.3	1744	46.7	4283	115	6321	169							
			175	12.1	2026	54.3	5920	159	7103	190							
			200	13.8	2312	62.0	6668	179	6028	162							
	16 in. w.c. / 40 mbar	20% Gauge	1	0.07			146	3.91	199	5.33	272	7.29	325	8.71			
			2	0.14	96	2.57	271	7.26	368	9.86	377	10.1	528	14.2			
			5	0.34	175	4.69	370	9.92	622	16.7	984	26.4	1074	28.8			
			8	0.55	232	6.22	560	15.0	818	21.9	1265	33.9	1348	36.1			
			20	1.4	300	8.04	1060	28.4	1607	43.1	2180	58.4	2380	63.8			
			35	2.4	561	15.0	1568	42.0	2309	61.9	3057	81.9	3439	92.2			
			60	4.1	867	23.2	2396	64.2	3082	82.6	5909	158	3732	100			
			75	5.2	1040	27.9	2846	76.3	3672	98.4	7368	197	5718	153			
			100	6.9	1362	36.5	3347	89.7	5824	156	7573	203	6407	172			
			125	8.6	1563	41.9	4419	118	6766	181	7028	188					
			150	10.3	1778	47.7	5135	138	5567	149							
			175	12.1	2101	56.3	6551	176	8708	233							
			200	13.8	2360	63.2	7865	211	8286	222							
			0.5 to 1.2 psig / 34 to 83 mbar Yellow	0.58 psig / 40 mbar	20% Gauge	2	0.14	103	2.76	257	6.89	325	8.71	343	9.19	2517	67.5
						6	0.41	190	5.09	242	6.49	631	16.9	937	25.1	1119	30.0
10	0.69	256				6.86	650	17.4	851	22.8	1272	34.1	1462	39.2			
30	2.1	328				8.79	1272	34.1	1692	45.3	2189	58.7	3097	83.0			
45	3.1	611				16.4	1722	46.1	2448	65.6	3071	82.3	3940	106			
60	4.1	852				22.8	1937	51.9	2610	69.9	4895	131	4721	127			
80	5.5	1055				28.3	2505	67.1	4702	126	5246	141	5879	158			
100	6.9	1301				34.9	2936	78.7	5186	139	6014	161	5666	152			
125	8.6	1530				41.0	3693	99.0	4440	119	6976	187	6172	165			
150	10.3	1821				48.8	4964	133	7252	194	6382	171					
175	12.1	2088		56.0	5526	148	7147	192									
200	13.8	2304		61.7	6208	166	6515	175									
1 psi / 69 mbar	20% Gauge	2		0.14	80	2.14	254	6.81	377	10.1	558	15.0	397	10.6			
		6		0.41	204	5.47	370	9.92	816	21.9	1187	31.8	1280	34.3			
		10		0.69	287	7.69	798	21.4	1051	28.2	1545	41.4	1713	45.9			
		30		2.1	507	13.6	1603	43.0	2272	60.9	3445	92.3	3804	102			
		60		4.1	871	23.3	2674	71.7	3489	93.5	6426	172	6832	183			
		80		5.5	1083	29.0	3267	87.6	4451	119	6951	186	7680	206			
		100		6.9	1361	36.5	3981	107	5293	142	8009	215	8880	238			
		125		8.6	1593	42.7	4699	126	6747	181	9750	261	10,421	279			
		150	10.3	1916	51.3	6298	169	8902	239	10,291	276						
		175	12.1	2136	57.2	6859	184	8570	230								
200	13.8	2421	64.9	7463	200	10,523	282										
1.2 to 2.5 psig / 83 to 172 mbar Green	1.2 psi / 83 mbar	20% Gauge	4	0.28	144	3.86	292	7.83	354	9.49	558	15.0	551	14.8			
			8	0.55	194	5.20	455	12.2	607	16.3	855	22.9	954	25.6			
			12	0.83	259	6.94	583	15.6	757	20.3	1109	29.7	1237	33.2			
			30	2.1	230	6.16	1017	27.3	1442	38.6	1875	50.2	2061	55.2			
			60	4.1	734	19.7	1710	45.8	2321	62.2	3859	103	4083	109			
			80	5.5	916	24.5	2119	56.8	2868	76.9	4647	125	5277	141			
			100	6.9	1122	30.1	2546	68.2	3402	91.2	5445	146	5992	161			
			125	8.6	1341	35.9	3046	81.6	4301	115	6528	175	5965	160			
			150	10.3	1537	41.2	3584	96.1	5313	142	7493	201	6600	177			
			175	12.1	1731	46.4	4051	109	6014	161	7346	197	7023	188			
200	13.8	2011	53.9	4539	122	5542	149	8020	215	7371	198						

     - Black areas indicate where desired flow capacity is not obtainable for a given inlet pressure.  
     - Shaded areas indicate where maximum operating inlet pressure for a given orifice size is exceeded.  
 1. Use 3/4 in. body capacities for flanged 3/4 x 1 in. construction.

- continued -

# T205 Series

**Table 9. Flow Capacities of Types T205M and T205HM with 3/4 in. / DN 20 Body Size (continued)<sup>(1)</sup>**

SPRING RANGE AND COLOR	OUTLET PRESSURE SETTING	OFFSET FROM SETPOINT	INLET PRESSURE		CAPACITIES IN SCFH / Nm <sup>3</sup> /h OF AIR									
					Orifice Size, In. / mm									
					1/8 / 3.2		1/4 / 6.4		3/8 / 9.5		1/2 / 13		9/16 / 14	
					psig	bar	SCFH	Nm <sup>3</sup> /h	SCFH	Nm <sup>3</sup> /h	SCFH	Nm <sup>3</sup> /h	SCFH	Nm <sup>3</sup> /h
1.2 to 2.5 psig / 83 to 172 mbar  Green	2.5 psi / 172 mbar	20% Gauge	6	0.41	179	4.80	481	12.9	604	16.2	984	26.4	1041	27.9
			10	0.69	246	6.59	718	19.2	989	26.5	1413	37.9	1421	38.1
			30	2.1	399	10.7	1486	39.8	2191	58.7	2859	76.6	3197	85.7
			60	4.1	882	23.6	2597	69.6	3662	98.1	5117	137	5597	150
			80	5.5	1102	29.5	3269	87.6	4494	120	6285	168	6838	183
			100	6.9	1340	35.9	3758	101	5300	142	7863	211	9172	246
			125	8.6	1611	43.2	4687	126	6442	173	9048	242	10,720	287
			150	10.3	1854	49.7	5383	144	7725	207	11,557	310	11,479	308
			175	12.1	2175	58.3	6267	168	9827	263	12,419	333	12,612	338
200	13.8	2499	67.0	6876	184	10,250	275	13,775	369	12,236	328			
2.5 to 4.5 psig / 0.17 to 0.31 bar  Light blue	2.5 psi / 0.17 bar	20% Gauge	4	0.28	106	2.84	266	7.13	318	8.52	366	9.81	438	11.7
			8	0.55	170	4.56	198	5.31	562	15.1	810	21.7	860	23.0
			12	0.83	232	6.22	548	14.7	651	17.4	1050	28.1	1213	32.5
			30	2.1	240	6.43	1023	27.4	1397	37.4	1940	52.0	2121	56.8
			60	4.1	738	19.8	1691	45.3	2424	65.0	3337	89.4	4945	133
			80	5.5	940	25.2	2132	57.1	2994	80.2	4246	114	5009	134
			100	6.9	1133	30.4	2549	68.3	3422	91.7	5956	160	6061	162
			125	8.6	1377	36.9	3057	81.9	4185	112	6570	176	7354	197
			150	10.3	1639	43.9	3641	97.6	5498	147	7866	211	8703	233
	175	12.1	1857	49.8	4043	108	5503	147	8509	228	8230	221		
	200	13.8	2109	56.5	4579	123	6288	169	8974	241	9551	256		
	4.5 psi / 0.31 bar	20% Gauge	8	0.55	194	5.20	500	13.4	658	17.6	959	25.7	1064	28.5
			12	0.83	258	6.91	600	16.1	974	26.1	1315	35.2	1497	40.1
			30	2.1	369	9.89	1363	36.5	1916	51.3	2686	72.0	2862	76.7
			60	4.1	899	24.1	2296	61.5	3254	87.2	4719	126	5680	152
			80	5.5	1095	29.3	2942	78.8	4153	111	6219	167	7130	191
			100	6.9	1301	34.9	3482	93.3	5253	141	7686	206	8659	98.1
			125	8.6	1571	42.1	4272	114	6156	165	9286	249	10,573	283
150			10.3	1843	49.4	5102	137	8001	214	10,993	295	10,700	287	
175			12.1	2097	56.2	5709	153	8504	228	12,480	334	11,930	320	
200	13.8	2341	62.7	6371	171	10,001	268	13,286	356	12,709	341			
4.5 to 7 psig / 0.31 to 0.48 bar  Black	4.5 psi / 0.31 bar	20% Gauge	9	0.62	181	4.85	253	6.78	765	20.5	816	21.9	828	22.2
			12	0.83	218	5.84	500	13.4	1027	27.5	1017	27.3	1459	39.1
			30	2.1	201	5.39	961	25.8	2022	54.2	2046	54.8	2070	55.5
			60	4.1	706	18.9	1715	46.0	3400	91.1	3486	93.4	3191	85.5
			80	5.5	919	24.6	2142	57.4	4274	115	4056	109	3865	104
			100	6.9	1132	30.3	2517	67.5	5108	137	4835	130	4965	133
			125	8.6	1372	36.8	3001	80.4	6367	171	6258	168	6777	182
			150	10.3	1607	43.1	3576	95.8	5503	147	6821	183	7785	209
			175	12.1	1845	49.4	3970	106	6034	162	7338	197	9084	243
	200	13.8	2034	54.5	4813	129	6852	184	9275	249	9521	255		
	7 psi / 0.48 bar	20% Gauge	9	0.62	167	4.48	433	11.6	812	21.8	902	24.2	909	24.4
			12	0.83	231	6.19	445	11.9	1021	27.4	987	26.5	1311	35.1
			30	2.1	290	7.77	1216	32.6	2427	65.0	2358	63.2	2723	73.0
			60	4.1	820	22.0	2138	57.3	4140	111	4442	119	5639	151
			80	5.5	1022	27.4	2681	71.9	5239	140	5636	151	6119	164
			100	6.9	1229	32.9	3259	87.3	6239	167	7095	190	7697	206
			125	8.6	1564	41.9	3884	104	7509	201	8007	215	8976	241
			150	10.3	1825	48.9	4572	123	6608	177	9391	252	10,626	285
175			12.1	2069	55.4	5029	135	8297	222	11,126	298	11,850	318	
200	13.8	2401	64.3	5686	152	9206	247	12,386	332	13,032	349			

1. Use 3/4 in. body capacities for flanged 3/4 x 1 in. construction.

**Table 10. Flow Capacities of Types T205M and T205HM with 1 in. / DN 25 Body Size**

SPRING RANGE AND COLOR	OUTLET PRESSURE SETTING	OFFSET FROM SETPOINT	INLET PRESSURE		CAPACITIES IN SCFH / Nm <sup>3</sup> /h OF AIR									
					Orifice Size, In. / mm									
					1/8 / 3.2		1/4 / 6.4		3/8 / 9.5		1/2 / 13		9/16 / 14	
					psig	bar	SCFH	Nm <sup>3</sup> /h	SCFH	Nm <sup>3</sup> /h	SCFH	Nm <sup>3</sup> /h	SCFH	Nm <sup>3</sup> /h
1 to 2.5 in. w.c. / 2.5 to 6.2 mbar  Orange	1 in. w.c. / 2.5 mbar	-1 to 2 in. w.c. / -2.5 to 5.0 mbar	1	0.07	94	2.52	342	9.17	602	16.1	890	23.9	929	24.9
			2	0.14	132	3.54	506	13.6	759	20.3	1345	36.0	1422	38.1
			5	0.34	208	5.57	768	20.6	1293	34.7	2143	57.4	2377	63.7
			10	0.69	310	8.31	1077	28.9	1968	52.7	3194	85.6	3679	98.6
			15	1.0	358	9.59	1350	36.2	2470	66.2	4107	110	4936	132
			20	1.4	423	11.3	1552	41.6	2949	79.0	5214	140	3462	92.8
			30	2.1	539	14.4	2022	54.2	4017	108	6933	186		
			40	2.8	677	18.1	2483	66.5	5111	137				
			60	4.1	878	23.5	3414	91.5						
			80	5.5	1097	29.4	4355	117						
	100	6.9	1236	33.1	5332	143								
	125	8.6	1549	41.5										
	150	10.3	1696	45.5										
	175	12.1	1988	53.3										
	200	13.8	2219	59.5										
	2 in. w.c. / 5.0 mbar	-1 to 2 in. w.c. / -2.5 to 5.0 mbar	1	0.07	81	2.17	325	8.71	507	13.6	828	22.2	952	25.5
			2	0.14	125	3.35	479	12.8	682	18.3	1112	29.8	1348	36.1
			5	0.34	204	5.47	740	19.8	1150	30.8	1996	53.5	2310	61.9
			10	0.69	291	7.80	1067	28.6	1699	45.5	2778	74.5	3604	96.6
			15	1.0	361	9.67	1279	34.3	1883	50.5	2553	68.4	3218	86.2
20			1.4	428	11.5	1504	40.3	2243	60.1	4510	121	3381	90.6	
30			2.1	545	14.6	2004	53.7	2846	76.3	5646	151			
40			2.8	662	17.7	2452	65.7	4050	109					
60			4.1	882	23.6	3347	89.7							
80			5.5	1067	28.6	4122	110							
100			6.9	1217	32.6	5192	139							
125			8.6	1528	41.0									
150			10.3	1708	45.8									
175			12.1	1957	52.4									
200	13.8	2184	58.5											
2.5 to 7 in. w.c. / 6.2 to 17 mbar  Red	2.5 in. w.c. / 6.2 mbar	-1 to 2 in. w.c. / -2.5 to 5.0 mbar	1	0.07	91	2.44	256	6.86	268	7.18	424	11.4	383	10.3
			2	0.14	126	3.38	297	7.96	408	10.9	694	18.6	640	17.2
			5	0.34	184	4.93	404	10.8	664	17.8	1084	29.1	1266	33.9
			10	0.69	282	7.56	782	21.0	959	25.7	1346	36.1	1426	38.2
			15	1.0	341	9.14	938	25.1	1081	29.0	1886	50.5	1210	32.4
			20	1.4	379	10.2	980	26.3	1232	33.0	2390	64.1		
			30	2.1	524	14.0	1462	39.2	1747	46.8	2492	66.8		
			40	2.8	650	17.4	1353	36.3	1582	42.4	2577	69.1		
			60	4.1	772	20.7	1840	49.3	2599	69.7				
			80	5.5	897	24.0	2339	62.7	9044	242				
			100	6.9	1166	31.2	2026	54.3						
			125	8.6	1439	38.6	5872	157						
			150	10.3	1628	43.6	7363	197						
			175	12.1	1776	47.6								
200	13.8	2210	59.2											

Shaded areas indicate where maximum operating inlet pressure for a given orifice size is exceeded.

- continued -

# T205 Series

**Table 10. Flow Capacities of Types T205M and T205HM with 1 in. / DN 25 Body Size (continued)**

SPRING RANGE AND COLOR	OUTLET PRESSURE SETTING	OFFSET FROM SETPOINT	INLET PRESSURE		CAPACITIES IN SCFH / Nm <sup>3</sup> /h OF AIR									
					Orifice Size, In. / mm									
					1/8 / 3.2		1/4 / 6.4		3/8 / 9.5		1/2 / 13		9/16 / 14	
			psig	bar	SCFH	Nm <sup>3</sup> /h	SCFH	Nm <sup>3</sup> /h	SCFH	Nm <sup>3</sup> /h	SCFH	Nm <sup>3</sup> /h	SCFH	Nm <sup>3</sup> /h
2.5 to 7 in. w.c. / 6.2 to 17 mbar  Red	4 in. w.c. / 10 mbar	-1 to 2 in. w.c. / -2.5 to 5.0 mbar	1	0.07	77	2.06	221	5.92	264	7.08	321	8.60	347	9.30
			2	0.14	117	3.14	266	7.13	277	7.42	433	11.6	593	15.9
			5	0.34	184	4.93	298	7.99	533	14.3	776	20.8	916	24.5
			10	0.69	266	7.13	661	17.7	726	19.5	1098	29.4	1232	33.0
			15	1.0	313	8.39	696	18.7	875	23.4	1205	32.3	1281	34.3
			20	1.4	318	8.52	885	23.7	1136	30.4	1650	44.2		
			30	2.1	447	12.0	918	24.6	1319	35.3	2009	53.8		
			40	2.8	589	15.8	1244	33.3	1439	38.6	1276	34.2		
			60	4.1	734	19.7	1458	39.1	1434	38.4				
			80	5.5	919	24.6	2242	60.1	1718	46.0				
	100	6.9	1090	29.2	1592	42.7								
	125	8.6	1339	35.9	3434	92.0								
	150	10.3	1419	38.0	3413	91.5								
	175	12.1	1796	48.1										
	200	13.8	2001	53.6										
	7 in. w.c. / 17.4 mbar	-2 to 2 in. w.c. / -5.0 to 5.0 mbar	1	0.07	83	2.22	284	7.61	410	11.0	607	16.3	596	16.0
			2	0.14	139	3.73	324	8.68	604	16.2	740	19.8	926	24.8
			5	0.34	191	5.12	578	15.5	895	24.0	1362	36.5	1521	40.8
			10	0.69	272	7.29	857	23.0	1369	36.7	1996	53.5	2490	66.7
			15	1.0	325	8.71	1037	27.8	1653	44.3	2467	66.1	1863	49.9
20			1.4	407	10.9	1277	34.2	1901	50.9	2916	78.1			
30			2.1	562	15.1	1579	42.3	2310	61.9	3372	90.4			
40			2.8	685	18.4	1871	50.1	2701	72.4	4074	109			
60			4.1	782	21.0	2672	71.6	4681	125					
80			5.5	888	23.8	2950	79.1	6235	167					
100			6.9	1162	31.1	2649	71.0							
125			8.6	1435	38.5	5770	155							
150			10.3	1718	46.0	6567	176							
175			12.1	1909	51.2									
200	13.8	2218	59.4											
7 to 16 in. w.c. / 17 to 40 mbar  Unpainted	8 in. w.c. / 20 mbar	-2 to 2 in. w.c. / -5.0 to 5.0 mbar	1	0.07	77	2.06	198	5.31	295	7.91	385	10.3	444	11.9
			2	0.14	124	3.32	285	7.64	361	9.67	403	10.8	699	18.7
			5	0.34	191	5.12	413	11.1	702	18.8	947	25.4	1100	29.5
			8	0.55	244	6.54	609	16.3	917	24.6	1368	36.7	1453	38.9
			20	1.4	369	9.89	992	26.6	1545	41.4	2163	58.0	2157	57.8
			35	2.4	573	15.4	1613	43.2	2115	56.7	2988	80.1	2895	77.6
			60	4.1	873	23.4	1979	53.0	2369	63.5	3249	87.1	3741	100
			75	5.2	991	26.6	2474	66.3	3225	86.4	3456	92.6	5058	136
			100	6.9	1123	30.1	2572	68.9	3761	101	4879	131	2851	76.4
			125	8.6	1419	38.0	4713	126	5937	159	5293	142		
	150	10.3	1681	45.1	5794	155	6001	161						
	175	12.1	2078	55.7										
	200	13.8	2208	59.2										
	12 in. w.c. / 30 mbar	20% Gauge	1	0.07	66	1.77	174	4.66	283	7.58	395	10.6	462	12.4
			2	0.14	115	3.08	256	6.86	411	11.0	466	12.5	692	18.5
			5	0.34	182	4.88	400	10.7	720	19.3	926	24.8	1108	29.7
			8	0.55	254	6.81	526	14.1	944	25.3	1297	34.8	1473	39.5
			20	1.4	343	9.19	1026	27.5	1498	40.1	2439	65.4	2208	59.2
			35	2.4	576	15.4	1422	38.1	2172	58.2	2679	71.8	3614	96.9
			60	4.1	836	22.4	2142	57.4	2578	69.1	3610	96.7	4418	118
75			5.2	1009	27.0	2595	69.5	3369	90.3	4373	117	4086	110	

Shaded areas indicate where maximum operating inlet pressure for a given orifice size is exceeded.

- continued -

**Table 10. Flow Capacities of Types T205M and T205HM with 1 in. / DN 25 Body Size (continued)**

SPRING RANGE AND COLOR	OUTLET PRESSURE SETTING	OFFSET FROM SETPOINT	INLET PRESSURE		CAPACITIES IN SCFH / Nm <sup>3</sup> /h OF AIR												
					Orifice Size, In. / mm												
					1/8 / 3.2		1/4 / 6.4		3/8 / 9.5		1/2 / 13		9/16 / 14				
					psig	bar	SCFH	Nm <sup>3</sup> /h	SCFH	Nm <sup>3</sup> /h	SCFH	Nm <sup>3</sup> /h	SCFH	Nm <sup>3</sup> /h	SCFH	Nm <sup>3</sup> /h	
7 to 16 in. w.c. / 17 to 40 mbar  Unpainted	12 in. w.c. / 30 mbar	20% Gauge	100	6.9	1125	30.2	2452	65.7	3572	95.7	5630	151	4909	132			
			125	8.6	1442	38.6	4534	122	6653	178	4721	127					
			150	10.3	1787	47.9	5560	149	6769	181							
			175	12.1	2075	55.6											
			200	13.8	2251	60.3											
	16 in. w.c. / 40 mbar	20% Gauge	1	0.07	75	2.01	175	4.69	273	7.32	392	10.5	496	13.3			
			2	0.14	112	3.00	280	7.50	428	11.5	455	12.2	730	19.6			
			5	0.34	191	5.12	433	11.6	831	22.3	1096	29.4	1248	33.4			
			8	0.55	254	6.81	605	16.2	1093	29.3	1400	37.5	1682	45.1			
			20	1.4	375	10.0	1198	32.1	1834	49.2	2856	76.5	2740	73.4			
			35	2.4	569	15.2	1627	43.6	2648	71.0	3178	85.2	3551	95.2			
			60	4.1	861	23.1	2338	62.7	3593	96.3	4725	127	5559	149			
			75	5.2	1001	26.8	2934	78.6	4225	113	4777	128	7172	192			
			100	6.9	1123	30.1	3187	85.4	5772	155	5722	153	4661	125			
			125	8.6	1463	39.2	5002	134	6948	186	4768	128					
			150	10.3	1817	48.7	6426	172	7714	207							
			175	12.1	2061	55.2											
			200	13.8	2203	59.0											
			0.5 to 1.2 psig / 34 to 83 mbar  Yellow	0.58 psig / 40 mbar	20% Gauge	2	0.14	115	3.08	297	7.96	435	11.7	541	14.5	545	14.6
						6	0.41	205	5.49	367	9.84	716	19.2	994	26.6	1181	31.7
10	0.69	284				7.61	661	17.7	988	26.5	1294	34.7	1568	42.0			
30	2.1	460				12.3	1293	34.7	1802	48.3	2527	67.7	2812	75.4			
45	3.1	680				18.2	1772	47.5	2248	60.2	3529	94.6	3109	83.3			
60	4.1	798				21.4	2070	55.5	2744	73.5	5128	137	4047	108			
80	5.5	1101				29.5	2511	67.3	3605	96.6	5625	151	4918	132			
100	6.9	1315				35.2	3048	81.7	5006	134	5459	146	5512	148			
125	8.6	1552				41.6	4531	121	6034	162	5451	146	6951	186			
150	10.3	1697				45.5	5057	136	7109	191	7307	196					
175	12.1	1890		50.7													
200	13.8	2085		55.9													
1 psi / 69 mbar	20% Gauge	2		0.14	100	2.68	293	7.85	525	14.1	648	17.4	596	16.0			
		6		0.41	208	5.57	558	15.0	934	25.0	1302	34.9	1507	40.4			
		10		0.69	277	7.42	765	20.5	1371	36.7	1775	47.6	1971	52.8			
		30		2.1	507	13.6	1721	46.1	2604	69.8	3287	88.1	3301	88.5			
		60		4.1	870	23.3	2727	73.1	4256	114	5175	139	3674	98.5			
		80		5.5	1095	29.3	3245	87.0	4918	132	6393	171	4299	115			
		100		6.9	1026	27.5	4586	123	7935	213	9443	253	7744	208			
		125		8.6	1332	35.7	5177	139	8135	218	9261	248	10,977	294			
		150	10.3	1626	43.6	6099	163	9407	252	10,410	279						
		175	12.1	1911	51.2												
200	13.8	2221	59.5														
1.2 to 2.5 psig / 83 to 172 mbar  Green	20% Gauge	4	0.28	136	3.64	349	9.35	348	9.33	585	15.7	634	17.0				
		8	0.55	204	5.47	385	10.3	592	15.9	859	23.0	1012	27.1				
		12	0.83	267	7.16	579	15.5	798	21.4	1120	30.0	1275	34.2				
		30	2.1	405	10.9	1072	28.7	1387	37.2	1860	49.8	2139	57.3				
		60	4.1	731	19.6	1732	46.4	2258	60.5	3141	84.2	1895	50.8				
		80	5.5	943	25.3	1967	52.7	2893	77.5	4481	120	4426	119				
		100	6.9	1139	30.5	2544	68.2	3170	85.0	4876	131	5197	139				
		125	8.6	1255	33.6	2900	77.7	3722	99.7	5556	149	5846	157				
		150	10.3	1590	42.6	3539	94.8	6305	169	7062	189	4813	129				
		175	12.1	1693	45.4	3845	103	6578	176	7683	206	6432	172				
200	13.8	1846	49.5	4449	119	6213	167	7189	193	4890	131						

Shaded areas indicate where maximum operating inlet pressure for a given orifice size is exceeded.

- continued -

# T205 Series

**Table 10. Flow Capacities of Types T205M and T205HM with 1 in. / DN 25 Body Size (continued)**

SPRING RANGE AND COLOR	OUTLET PRESSURE SETTING	OFFSET FROM SETPOINT	INLET PRESSURE		CAPACITIES IN SCFH / Nm <sup>3</sup> /h OF AIR									
					Orifice Size, In. / mm									
			psig	bar	1/8 / 3.2		1/4 / 6.4		3/8 / 9.5		1/2 / 13		9/16 / 14	
					SCFH	Nm <sup>3</sup> /h	SCFH	Nm <sup>3</sup> /h	SCFH	Nm <sup>3</sup> /h	SCFH	Nm <sup>3</sup> /h	SCFH	Nm <sup>3</sup> /h
1.2 to 2.5 psig / 83 to 172 mbar  Green	2.5 psi / 172 mbar	20% Gauge	6	0.41	191	5.12	521	14.0	765	20.5	1005	26.9	1167	31.3
			10	0.69	236	6.32	617	16.5	1104	29.6	1439	38.6	1750	46.9
			30	2.1	498	13.3	1382	37.0	2263	60.6	2783	74.6	3555	95.3
			60	4.1	837	22.4	2500	67.0	3273	87.7	5680	152	5186	139
			80	5.5	1074	28.8	2879	77.2	4586	123	7109	191	7606	204
			100	6.9	1291	34.6	3687	98.8	4967	133	8371	224	8584	230
			125	8.6	1565	41.9	4270	114	6512	175	10,046	269	10,446	280
			150	10.3	1904	51.0	5380	144	8462	227	10,021	269	11,642	312
			175	12.1	2019	54.1	5841	157	9454	253	12,684	340	13,557	363
200	13.8	2232	59.8	6593	177	11,421	306	13,394	359	12,786	343			
2.5 to 4.5 psig / 0.17 to 0.31 bar  Light blue	2.5 psi / 0.17 bar	20% Gauge	4	0.28	115	3.08	273	7.32	345	9.25	494	13.2	510	13.7
			8	0.55	206	5.52	295	7.91	584	15.7	825	22.1	972	26.0
			12	0.83	249	6.67	521	14.0	743	19.9	1074	28.8	1183	31.7
			30	2.1	374	10.0	1030	27.6	1393	37.3	1936	51.9	2156	57.8
			60	4.1	776	20.8	1581	42.4	2262	60.6	2710	72.6	3174	85.1
			80	5.5	1018	27.3	2141	57.4	2933	78.6	3652	97.9	3995	107
			100	6.9	1129	30.3	2615	70.1	3156	84.6	4379	117	5528	148
			125	8.6	1351	36.2	3143	84.2	4001	107	5686	152	5083	136
			150	10.3	1634	43.8	3778	101	5735	154	5956	160	7722	207
			175	12.1	1899	50.9	4050	109	6031	162	7622	204	9369	251
	200	13.8	1997	53.5	4421	118	7327	196	9291	249	9609	258		
	4.5 psi / 0.31 bar	20% Gauge	8	0.55	206	5.52	415	11.1	708	19.0	1012	27.1	1070	28.7
			12	0.83	276	7.40	534	14.3	993	26.6	1369	36.7	1425	38.2
			30	2.1	512	13.7	1334	35.8	2008	53.8	2720	72.9	2998	80.3
			60	4.1	875	23.4	2261	60.6	3573	95.8	4304	115	4989	134
			80	5.5	1127	30.2	2826	75.7	4302	115	5804	156	6241	167
			100	6.9	1287	34.5	3504	93.9	5338	143	7023	188	8371	224
			125	8.6	1662	44.5	4177	112	6565	176	8183	219	9844	264
			150	10.3	1741	46.7	4888	131	7755	208	10,151	272	11,535	309
			175	12.1	1981	53.1	5486	147	9965	267	11,236	301	11,864	318
200			13.8	2277	61.0	6487	174	10,233	274	12,388	332	14,093	378	
4.5 to 7 psig / 0.31 to 0.48 bar  Black	4.5 psi / 0.31 bar	20% Gauge	9	0.62	192	5.15	251	6.73	600	16.1	772	20.7	823	22.1
			12	0.83	240	6.43	423	11.3	743	19.9	1039	27.8	1131	30.3
			30	2.1	441	11.8	1023	27.4	1404	37.6	1925	51.6	2185	58.6
			60	4.1	802	21.5	1708	45.8	2400	64.3	3265	87.5	3392	90.9
			80	5.5	977	26.2	2094	56.1	3023	81.0	3832	103	4177	112
			100	6.9	1095	29.3	2603	69.8	3390	90.9	5180	139	4967	133
			125	8.6	1336	35.8	3247	87.0	3852	103	5686	152	6346	170
			150	10.3	1479	39.6	3771	101	5719	153	7056	189	7172	192
			175	12.1	1729	46.3	4222	113	6197	166	7609	204	8573	230
	200	13.8	2036	54.6	4518	121	6915	185	8098	217	8150	218		
	7 psi / 0.48 bar	20% Gauge	9	0.62	184	4.93	455	12.2	575	15.4	900	24.1	936	25.1
			12	0.83	244	6.54	424	11.4	712	19.1	1208	32.4	1328	35.6
			30	2.1	414	11.1	1269	34.0	1800	48.2	2647	70.9	2772	74.3
			60	4.1	747	20.0	2075	55.6	2916	78.1	4721	127	5075	136
			80	5.5	1005	26.9	2772	74.3	3965	106	5636	151	5824	156
			100	6.9	1308	35.1	3383	90.7	4053	109	6244	167	6849	184
			125	8.6	1593	42.7	3952	106	5454	146	7249	194	8606	231
			150	10.3	1665	44.6	4565	122	7208	193	9515	255	11,109	298
175			12.1	1925	51.6	5309	142	8473	227	10,620	285	11,872	318	
200	13.8	2257	60.5	5791	155	9592	257	11,706	314	12,938	347			

**Table 11. C<sub>v</sub> Coefficient of T205 Series with 3/4 in. / DN 20 Body Size<sup>(1)</sup>**

SPRING RANGE AND COLOR	OUTLET PRESSURE SETTING	OFFSET FROM SETPOINT	INLET PRESSURE		C <sub>v</sub> COEFFICIENT												
					Orifice Size, In. / mm												
					1/8 / 3.2		1/4 / 6.4		3/8 / 9.5		1/2 / 13		9/16 / 14				
					Type												
		psig	bar	T205	T205M	T205	T205M	T205	T205M	T205	T205M	T205	T205M				
1 to 2.5 in. w.c. / 2.5 to 6.2 mbar	1 in. w.c. / 2.5 mbar	-1 to 2 in. w.c. / -2.5 to 5.0 mbar	1	0.07	0.3	0.3	1.0	1.3	1.4	2.1	2.6	2.9	2.5	3.2			
			2	0.14	0.4	0.4	1.2	1.3	1.9	2.3	2.1	2.8	2.4	4.2			
			5	0.34	0.4	0.4	1.2	1.5	1.5	2.2	1.9	3.7	2.0	3.8			
			10	0.69	0.4	0.4	1.1	1.5	1.3	2.6	1.8	3.4	1.8	3.4			
			15	1.0	0.4	0.4	1.1	1.5	1.3	2.1	1.6	2.9	1.2	5.1			
			20	1.4	0.4	0.4	1.1	1.5	1.2	2.7	1.5	4.4	1.1	4.4			
			30	2.1	0.4	0.4	1.0	1.8	1.1	2.7	1.0	4.4					
			40	2.8	0.4	0.4	1.0	2.0	0.7	1.8							
			60	4.1	0.4	0.4	0.8	1.7	0.5	3.0							
			80	5.5	0.4	0.4	0.5	1.4									
			100	6.9	0.4	0.4	0.4	1.4									
			125	8.6	0.4	0.4	0.4	1.4									
			150	10.3	0.4	0.4											
			175	12.1	0.3	0.4											
			200	13.8	0.2	0.4											
			Orange	2 in. w.c. / 5.0 mbar	-1 to 2 in. w.c. / -2.5 to 5.0 mbar	1	0.07	0.3	0.3	1.0	1.2	1.3	2.0	2.0	2.4	2.1	3.2
						2	0.14	0.3	0.4	1.1	1.4	1.8	2.0	1.9	2.2	2.2	3.3
						5	0.34	0.4	0.4	1.1	1.4	1.4	2.0	1.7	2.9	1.9	2.8
						10	0.69	0.4	0.4	1.1	1.4	1.2	1.8	1.7	2.8	1.7	3.1
						15	1.0	0.4	0.4	1.0	1.4	1.2	1.7	1.6	2.7	1.2	4.0
20	1.4	0.4				0.4	1.0	1.4	1.2	2.2	1.1	2.5	0.9	3.4			
30	2.1	0.4				0.4	1.0	1.4	1.0	2.4	0.8	2.4					
40	2.8	0.4				0.4	0.9	1.4	0.7	1.6							
60	4.1	0.4				0.4	0.8	1.4	0.9	1.9							
80	5.5	0.4				0.4	0.4	1.1									
100	6.9	0.4				0.4	0.4	1.3									
125	8.6	0.4				0.4	0.3	1.4									
150	10.3	0.3				0.4											
175	12.1	0.3				0.4											
200	13.8	0.2				0.4											
Red	2.5 in. w.c. / 6.2 mbar	-1 to 2 in. w.c. / -2.5 to 5.0 mbar				1	0.07	0.3	0.3	0.6	0.8	1.1	1.2	1.5	2.5	1.5	1.9
						2	0.14	0.3	0.3	0.6	0.9	1.4	1.0	1.6	1.2	1.5	1.8
						5	0.34	0.3	0.4	0.6	0.5	1.0	1.2	1.4	1.6	1.5	1.8
						10	0.69	0.4	0.4	0.7	0.8	1.0	1.0	1.4	1.5	1.5	1.6
						15	1.0	0.4	0.4	0.7	0.9	1.0	1.1	1.4	1.2	1.2	2.4
			20	1.4	0.4	0.3	0.7	0.8	1.1	1.2	1.4	1.4	1.0	2.1			
			30	2.1	0.4	0.3	1.2	0.9	0.9	1.1	0.7	2.2	0.8	1.0			
			40	2.8	0.4	0.4	0.7	0.8	0.8	0.9	0.5	2.8					
			60	4.1	0.3	0.3	0.7	0.6	0.9	1.1							
			80	5.5	0.3	0.3	0.5	0.6	0.4	1.7							
	100	6.9	0.3	0.3	0.7	0.6											
	125	8.6	0.3	0.3	0.3	0.5											
	150	10.3	0.3	0.3	0.3	1.2											
	175	12.1	0.3	0.3	0.3	1.4											
	200	13.8	0.2	0.3													
	4 in. w.c. / 10 mbar	-1 to 2 in. w.c. / -2.5 to 5.0 mbar	1	0.07	0.3	0.4	0.5	0.8	0.8	1.3	1.3	1.4	1.3	1.4			
			2	0.14	0.3	0.3	0.6	0.8	1.2	0.9	1.4	0.9	1.4	1.5			
			5	0.34	0.3	0.3	0.7	0.4	1.0	0.9	1.2	1.3	1.4	1.5			
			10	0.69	0.3	0.3	0.7	0.7	0.9	0.9	1.3	1.3	1.6	1.4			
			15	1.0	0.3	0.3	0.7	0.7	1.0	1.0	1.3	1.3	1.0	1.4			
20			1.4	0.3	0.2	0.8	0.7	1.0	0.9	1.3	1.1	0.9	1.4				
30			2.1	0.3	0.3	1.1	0.8	0.9	1.0	1.2	1.4	0.7	1.0				
40			2.8	0.4	0.3	0.8	0.7	0.8	0.8	0.9	2.0						
60			4.1	0.3	0.3	0.7	0.6	0.6	0.6								
80			5.5	0.4	0.3	0.6	0.5	0.4	0.7								
100	6.9	0.3	0.3	0.7	0.4												
125	8.6	0.3	0.3	0.4	0.4												
150	10.3	0.3	0.3	0.3	0.7												
175	12.1	0.3	0.3	0.3	0.6												
200	13.8	0.2	0.3														

Shaded areas indicate where maximum operating inlet pressure for a given orifice size is exceeded.  
1. Use 3/4 in. body C<sub>v</sub> Coefficient for flanged 3/4 x 1 in. construction.

- continued -

# T205 Series

**Table 11. C<sub>v</sub> Coefficient of T205 Series with 3/4 in. / DN 20 Body Size (continued)<sup>(1)</sup>**

SPRING RANGE AND COLOR	OUTLET PRESSURE SETTING	OFFSET FROM SETPOINT	INLET PRESSURE		C <sub>v</sub> COEFFICIENT													
					Orifice Size, In. / mm													
					1/8 / 3.2		1/4 / 6.4		3/8 / 9.5		1/2 / 13		9/16 / 14					
					Type													
psig	bar	T205	T205M	T205	T205M	T205	T205M	T205	T205M	T205	T205M	T205	T205M					
2.5 to 7 in. w.c. / 6.2 to 17 mbar  Red	7 in. w.c. / 17 mbar	-2 to 2 in. w.c. / -5.0 to 5.0 mbar	1	0.07	0.4	0.3	0.7	0.9	1.3	1.6	1.7	1.8	1.7	2.6				
			2	0.14	0.3	0.3	0.9	1.0	1.6	1.7	2.0	1.5	1.9	2.5				
			5	0.34	0.4	0.4	1.0	0.8	1.3	1.3	1.8	2.2	1.9	2.3				
			10	0.69	0.4	0.4	1.0	1.1	1.3	1.5	1.8	2.1	1.9	2.3				
			15	1.0	0.4	0.4	1.0	1.1	1.2	1.5	1.7	1.9	1.5	2.5				
			20	1.4	0.4	0.3	0.9	1.1	1.2	1.6	1.4	2.0	1.3	2.7				
			30	2.1	0.4	0.4	1.1	1.1	1.0	1.7	1.4	3.2	1.0	2.7				
			40	2.8	0.4	0.4	0.9	1.1	1.1	1.4	1.0	2.8						
			60	4.1	0.4	0.4	0.8	1.0	0.9	1.7								
			80	5.5	0.4	0.4	0.9	1.0	0.8	1.9								
			100	6.9	0.4	0.4	0.7	1.0										
			125	8.6	0.4	0.4	0.4	1.0										
			150	10.3	0.4	0.4	0.3	1.3										
			175	12.1	0.3	0.4	0.3	1.3										
			200	13.8	0.2	0.4												
			7 to 16 in. w.c. / 17 to 40 mbar  Unpainted	8 in. w.c. / 20 mbar	-2 to 2 in. w.c. / -5.0 to 5.0 mbar	1	0.07	0.3	0.3	0.8	1.0	1.0	1.2	1.2	1.6	1.6	1.5	
						2	0.14	0.3	0.3	0.7	0.9	1.2	1.2	1.6	0.9	1.7	1.5	
5	0.34	0.3				0.4	0.9	0.6	1.1	1.1	1.7	1.7	1.7	1.9				
8	0.55	0.3				0.4	0.8	0.8	1.1	1.1	1.6	1.7	1.7	1.8				
20	1.4	0.3				0.2	0.9	0.9	1.1	1.2	1.5	1.6	1.4	1.7				
35	2.4	0.4				0.2	0.9	0.9	0.9	1.2	0.9	2.1	1.0	1.8				
60	4.1	0.3				0.3	0.7	0.8	0.9	0.9	1.1	1.8	1.3	1.8				
75	5.2	0.3				0.3	0.7	0.8	0.7	0.9	0.9	1.7	1.2	1.8				
100	6.9	0.3				0.3	0.7	0.7	0.5	0.7	0.6	1.6	0.8	1.4				
125	8.6	0.3				0.3	0.4	0.8	0.6	1.2	0.5	1.2						
150	10.3	0.3				0.3	0.3	0.7	0.3	0.7								
175	12.1	0.3				0.3	0.3	1.0	0.2	0.8								
200	13.8	0.2				0.3	0.3	1.0	0.2	0.7								
12 in. w.c. / 30 mbar	20% Gauge					1	0.07	0.5		0.6	0.8	1.2	1.1	1.4	1.5	1.3	1.5	
						2	0.14	0.3	0.3	0.8	0.9	1.2	1.3	1.4	0.9	1.6	1.8	
						5	0.34	0.3	0.3	0.9	0.6	1.2	1.1	1.6	1.8	1.7	1.9	
						8	0.55	0.3	0.3	0.9	0.8	1.1	1.1	1.6	1.7	1.8	1.9	
				20	1.4	0.3	0.2	0.9	1.0	1.1	1.3	1.5	1.6	1.4	1.7			
				35	2.4	0.4	0.2	0.9	0.9	0.9	1.1	1.1	1.4	1.6	2.2			
				60	4.1	0.4	0.3	0.7	0.8	0.9	1.1	1.0	1.9	1.4	2.1			
				75	5.2	0.3	0.3	0.7	0.8	0.7	1.0	0.9	1.8	1.2	1.7			
				100	6.9	0.3	0.3	0.7	0.8	0.5	1.1	0.6	1.6	0.7	1.5			
				125	8.6	0.3	0.3	0.4	0.8	0.7	1.3	0.5	1.1					
				150	10.3	0.3	0.3	0.4	0.8	0.3	1.1							
				175	12.1	0.3	0.3	0.3	1.0	0.2	1.1							
				200	13.8	0.4	0.3	0.3	1.0	0.2	0.8							
				16 in. w.c. / 40 mbar	20% Gauge		1	0.07			0.7	1.0	1.3	1.3	1.5	1.8	1.6	2.2
							2	0.14	0.3	0.3	0.8	1.0	1.4	1.3	1.7	1.4	1.9	1.9
							5	0.34	0.4	0.4	1.0	0.8	1.3	1.3	1.9	2.0	1.9	2.2
							8	0.55	0.3	0.4	0.9	0.9	1.2	1.3	1.8	2.0	1.9	2.1
							20	1.4	0.3	0.3	0.9	1.0	1.2	1.4	1.5	1.9	1.6	2.1
35	2.4	0.4					0.3	1.0	1.0	1.0	1.4	1.1	1.9	1.7	2.1			
60	4.1	0.3					0.4	0.8	1.0	0.9	1.2	1.2	2.4	1.4	1.5			
75	5.2	0.4					0.4	0.9	1.0	0.7	1.2	0.9	2.5	1.2	1.9			
100	6.9	0.3					0.4	0.7	0.9	0.6	1.5	0.7	2.0	0.8	1.7			
125	8.6	0.4	0.3				0.6	1.0	0.7	1.4	0.6	1.5						
150	10.3	0.3	0.3				0.4	1.0	0.6	1.0								
175	12.1	0.3	0.3				0.3	1.1	0.5	1.4								
200	13.8	0.4	0.3				0.4	1.1	0.5	1.2								

     - Black areas indicate where desired flow capacity is not obtainable for a given inlet pressure.  
     - Shaded areas indicate where maximum operating inlet pressure for a given orifice size is exceeded.  
 1. Use 3/4 in. body C, Coefficient for flanged 3/4 x 1 in. construction.

- continued -



**Table 11. C<sub>v</sub> Coefficient of T205 Series with 3/4 in. / DN 20 Body Size (continued)<sup>(1)</sup>**

SPRING RANGE AND COLOR	OUTLET PRESSURE SETTING	OFFSET FROM SETPOINT	INLET PRESSURE		C <sub>v</sub> COEFFICIENT									
					Orifice Size, In. / mm									
					1/8 / 3.2		1/4 / 6.4		3/8 / 9.5		1/2 / 13		9/16 / 14	
					Type									
		T205	T205M	T205	T205M	T205	T205M	T205	T205M	T205	T205M			
0.5 to 1.2 psig / 34 to 83 mbar Yellow	0.58 psig / 40 mbar	20% Gauge	2	0.14	0.4	0.4	0.8	0.9	1.3	1.2	1.7	1.2	1.7	1.0
			6	0.41	0.3	0.3	0.8	0.4	1.1	1.2	1.7	1.7	1.7	2.1
			10	0.69	0.3	0.4	0.9	0.9	1.2	1.2	1.7	1.7	1.9	2.0
			30	2.1	0.3	0.2	0.9	0.9	1.1	1.1	1.0	1.5	1.4	2.1
			45	3.1	0.3	0.3	1.0	0.9	0.8	1.2	1.1	1.6	1.5	2.0
			60	4.1	0.3	0.3	0.8	0.8	1.0	1.0	0.8	2.0	1.4	1.9
			80	5.5	0.3	0.3	0.9	0.8	0.7	1.5	0.8	1.7	0.9	1.9
			100	6.9	0.3	0.3	0.7	0.8	0.6	1.3	0.7	1.6	0.8	1.5
			125	8.6	0.3	0.3	0.4	0.8	0.6	0.9	0.5	1.5	0.7	1.4
			150	10.3	0.3	0.3	0.4	0.9	0.5	1.3	0.4	1.2		
	175	12.1	0.3	0.3	0.3	0.9	0.5	1.1						
	200	13.8	0.4	0.3	0.3	0.9	0.4	0.9						
	2	0.14	0.5	0.3	1.1	1.1	1.7	1.6	2.2	2.4	2.3	1.7		
	1 psi / 69 mbar	20% Gauge	6	0.41	0.4	0.4	1.0	0.7	1.4	1.5	2.1	2.2	2.1	2.4
			10	0.69	0.4	0.4	1.1	1.1	1.4	1.4	2.0	2.1	2.3	2.4
			30	2.1	0.4	0.3	1.0	1.1	1.2	1.5	1.5	2.3	1.5	2.6
			60	4.1	0.4	0.4	0.9	1.1	1.0	1.4	1.1	2.6	1.5	2.8
			80	5.5	0.4	0.3	0.9	1.1	0.7	1.4	1.0	2.2	1.2	2.5
			100	6.9	0.4	0.4	0.8	1.1	0.6	1.4	0.8	2.1	0.9	2.4
			125	8.6	0.4	0.3	0.5	1.0	0.7	1.4	0.6	2.1	0.8	2.3
150			10.3	0.4	0.4	0.6	1.2	0.7	1.6	0.5	1.9			
175			12.1	0.4	0.3	0.6	1.1	0.6	1.3					
200			13.8	0.4	0.3	0.4	1.1	0.5	1.5					
4	0.28	0.3	0.4	0.7	0.7	1.0	0.9	1.4	1.4	1.5	1.4			
1.2 to 2.5 psig / 83 to 172 mbar Green	1.2 psi / 83 mbar	20% Gauge	8	0.55	0.3	0.3	0.7	0.7	0.9	1.0	1.4	1.4	1.5	1.5
			12	0.83	0.3	0.3	0.7	0.7	0.9	0.9	1.4	1.4	1.4	1.5
			30	2.1	0.3	0.2	0.7	0.7	1.0	1.0	1.1	1.3	1.4	1.6
			60	4.1	0.3	0.3	0.7	0.7	0.9	0.9	1.3	1.6	1.3	1.7
			80	5.5	0.3	0.3	0.6	0.7	0.7	0.9	1.0	1.5	1.2	1.7
			100	6.9	0.3	0.3	0.7	0.7	0.6	0.9	0.7	1.4	0.8	1.6
			125	8.6	0.3	0.3	0.7	0.7	0.5	0.9	0.6	1.4	0.7	1.3
			150	10.3	0.3	0.3	0.6	0.7	0.6	1.0	0.5	1.4	0.6	1.2
			175	12.1	0.3	0.3	0.7	0.7	0.5	0.9	0.4	1.2	0.6	1.1
			200	13.8	0.4	0.3	0.6	0.7	0.5	0.8	0.4	1.1	0.5	1.1
	2.5 psi / 0.17 bar	20% Gauge	6	0.41	0.3	0.4	1.0	1.0	1.5	1.3	2.1	2.1	2.2	2.3
			10	0.69	0.4	0.4	1.0	1.1	1.4	1.4	2.0	2.1	2.1	2.1
			30	2.1	0.3	0.3	1.0	1.0	1.4	1.5	1.8	2.0	1.3	2.2
			60	4.1	0.3	0.4	0.9	1.1	1.1	1.5	1.3	2.1	1.6	2.3
			80	5.5	0.4	0.4	1.0	1.1	1.0	1.4	1.2	2.0	1.4	2.2
			100	6.9	0.4	0.4	0.9	1.0	0.8	1.4	1.1	2.1	1.3	2.4
			125	8.6	0.4	0.4	0.8	1.0	0.8	1.4	0.8	2.0	0.9	2.4
			150	10.3	0.4	0.3	0.7	1.0	0.7	1.4	0.7	2.1	0.8	2.1
			175	12.1	0.4	0.3	0.7	1.0	0.6	1.5	0.6	2.0	0.7	2.0
			200	13.8	0.4	0.4	0.7	1.0	0.6	1.4	0.5	2.0	0.6	1.8
2.5 to 4.5 psig / 0.17 to 0.31 bar Light blue	2.5 psi / 0.17 bar	20% Gauge	4	0.28	0.4	0.4	0.7	0.9	1.1	1.1	1.6	1.2	1.6	1.5
			8	0.55	0.4	0.3	0.7	0.3	1.0	1.0	1.4	1.4	1.5	1.5
			12	0.83	0.4	0.3	0.7	0.7	1.0	0.8	1.4	1.4	1.5	1.6
			30	2.1	0.4	0.2	0.7	0.7	1.2	0.9	1.2	1.3	1.3	1.5
			60	4.1	0.4	0.3	0.7	0.7	1.0	1.0	1.1	1.3	1.4	2.0
			80	5.5	0.4	0.3	0.7	0.7	0.9	0.9	1.2	1.4	1.3	1.6
			100	6.9	0.4	0.3	0.7	0.7	0.8	0.9	1.0	1.6	1.0	1.6
			125	8.6	0.3	0.3	0.7	0.7	0.7	0.9	0.8	1.4	0.8	1.6
			150	10.3	0.4	0.3	0.7	0.7	0.7	1.0	0.7	1.5	0.7	1.6
			175	12.1	0.4	0.3	0.6	0.7	0.6	0.9	0.6	1.4	0.7	1.3
	200	13.8	0.4	0.3	0.6	0.7	0.6	0.9	0.5	1.3	0.6	1.4		
	4.5 psi / 0.31 bar	20% Gauge	8	0.55	0.4	0.4	0.9	1.0	1.5	1.4	2.0	2.0	2.1	2.2
			12	0.83	0.4	0.4	0.9	0.8	1.3	1.3	1.9	1.8	2.1	2.1
			30	2.1	0.4	0.3	0.9	0.9	1.2	1.3	1.8	1.9	1.8	2.0
			60	4.1	0.4	0.4	0.9	0.9	1.2	1.3	1.5	1.9	1.8	2.3
			80	5.5	0.4	0.3	0.9	0.9	1.1	1.3	1.2	2.0	1.6	2.3
			100	6.9	0.3	0.3	0.9	0.9	0.9	1.4	1.2	2.0	1.4	1.0
			125	8.6	0.4	0.3	0.8	0.9	0.8	1.3	1.1	2.0	1.2	2.3
			150	10.3	0.4	0.3	0.8	0.9	0.8	1.4	1.0	2.0	1.0	2.0
			175	12.1	0.3	0.3	0.7	0.9	0.7	1.3	0.9	2.0	0.9	1.9
200			13.8	0.3	0.3	0.7	0.9	0.7	1.4	0.7	1.9	0.8	1.8	

Shaded areas indicate where maximum operating inlet pressure for a given orifice size is exceeded.  
 1. Use 3/4 in. body C<sub>v</sub> Coefficient for flanged 3/4 x 1 in. construction.

- continued -

# T205 Series

**Table 11. C<sub>v</sub> Coefficient of T205 Series with 3/4 in. / DN 20 Body Size (continued)<sup>(1)</sup>**

SPRING RANGE AND COLOR	OUTLET PRESSURE SETTING	OFFSET FROM SETPOINT	INLET PRESSURE		C <sub>v</sub> COEFFICIENT									
					Orifice Size, In. / mm									
					1/8 / 3.2		1/4 / 6.4		3/8 / 9.5		1/2 / 13		9/16 / 14	
					Type									
				T205	T205M	T205	T205M	T205	T205M	T205	T205M	T205	T205M	
4.5 to 7 psig / 0.31 to 0.48 bar  Black	4.5 psi / 0.31 bar	20% Gauge	9	0.62	0.3	0.3	0.7	0.5	1.0	1.4	1.4	1.5	1.6	1.5
			12	0.83	0.3	0.3	0.7	0.7	1.0	1.4	1.2	1.4	1.5	2.0
			30	2.1	0.3	0.1	0.7	0.7	1.1	1.4	1.3	1.4	1.5	1.4
			60	4.1	0.3	0.3	0.7	0.7	1.0	1.3	1.1	1.4	1.5	1.3
			80	5.5	0.3	0.3	0.7	0.7	0.9	1.3	1.2	1.3	1.4	1.2
			100	6.9	0.3	0.3	0.7	0.7	0.8	1.3	1.2	1.3	1.2	1.3
			125	8.6	0.3	0.3	0.7	0.7	0.8	1.4	0.9	1.4	1.0	1.5
			150	10.3	0.3	0.3	0.7	0.7	0.7	1.0	0.9	1.3	0.9	1.5
			175	12.1	0.3	0.3	0.6	0.6	0.7	0.9	0.8	1.2	0.8	1.5
			200	13.8	0.3	0.3	0.6	0.7	0.6	0.9	0.7	1.3	0.7	1.4
	9	0.62	0.4	0.4	1.0	1.1	1.6	2.1	2.2	2.3	1.4	2.3		
	12	0.83	0.4	0.4	0.9	0.7	1.3	1.6	1.9	1.6	1.3	2.1		
	30	2.1	0.3	0.2	0.9	0.9	1.4	1.7	1.6	1.7	1.3	1.9		
	60	4.1	0.3	0.3	0.9	0.9	1.1	1.6	1.5	1.8	1.8	2.3		
	80	5.5	0.3	0.3	0.9	0.9	1.2	1.6	1.5	1.8	1.7	2.0		
	100	6.9	0.3	0.3	0.9	0.9	1.0	1.6	1.3	1.9	1.5	2.0		
	125	8.6	0.3	0.3	0.8	0.8	0.9	1.6	1.3	1.7	1.4	2.0		
	150	10.3	0.3	0.3	0.8	0.8	0.9	1.2	1.2	1.7	1.2	2.0		
	175	12.1	0.3	0.3	0.8	0.8	0.8	1.3	0.9	1.8	1.0	1.9		
	200	13.8	0.4	0.3	0.7	0.8	0.7	1.3	0.9	1.8	0.9	1.9		

1. Use 3/4 in. body C<sub>v</sub> Coefficient for flanged 3/4 x 1 in. construction.

**Table 12. C<sub>v</sub> Coefficient of T205 Series with 1 in. / DN 25 Body Size**

SPRING RANGE AND COLOR	OUTLET PRESSURE SETTING	OFFSET FROM SETPOINT	INLET PRESSURE		C <sub>v</sub> COEFFICIENT									
					Orifice Size, In. / mm									
					1/8 / 3.2		1/4 / 6.4		3/8 / 9.5		1/2 / 13		9/16 / 14	
					Type									
				T205	T205M	T205	T205M	T205	T205M	T205	T205M	T205	T205M	
1 to 2.5 in. w.c. / 2.5 to 6.2 mbar  Orange	1 in. w.c. / 2.5 mbar	-1 to 2 in. w.c. / -2.5 to 5.0 mbar	1	0.07	0.4	0.4	1.5	1.5	2.7	2.7	4.3	4.0	4.9	4.2
			2	0.14	0.4	0.4	1.5	1.6	2.6	2.4	4.0	4.2	4.5	4.5
			5	0.34	0.4	0.4	1.5	1.5	2.6	2.5	4.1	4.2	4.7	4.7
			10	0.69	0.4	0.4	1.4	1.5	2.6	2.6	4.3	4.3	2.6	5.0
			15	1.0	0.4	0.4	1.4	1.4	2.6	2.6	2.6	4.4	2.1	5.3
			20	1.4	0.4	0.4	1.4	1.4	2.0	2.6	1.6	4.6	1.6	3.1
			30	2.1	0.4	0.4	1.4	1.4	1.4	2.7	1.3	4.7		
			40	2.8	0.4	0.4	1.1	1.4	1.0	2.8				
			60	4.1	0.4	0.4	0.8	1.4						
			80	5.5	0.4	0.4	0.5	1.4						
	100	6.9	0.4	0.3	0.5	1.4								
	125	8.6	0.4	0.3										
	150	10.3	0.4	0.3										
	175	12.1	0.4	0.3										
	200	13.8	0.4	0.3										
	1	0.07	0.4	0.4	1.5	1.5	2.7	2.3	4.1	3.8	4.9	4.4		
	2	0.14	0.4	0.4	1.1	1.5	2.6	2.2	4.0	3.5	4.4	4.3		
	5	0.34	0.4	0.4	1.4	1.5	2.6	2.2	4.1	3.9	4.7	4.6		
	10	0.69	0.4	0.4	1.4	1.4	2.6	2.3	3.8	3.7	3.6	4.9		
	15	1.0	0.4	0.4	1.4	1.4	2.8	2.0	2.3	2.7	2.1	3.4		
20	1.4	0.4	0.4	1.4	1.3	2.3	2.0	1.7	4.0	1.6	3.0			
30	2.1	0.4	0.4	1.4	1.4	1.4	1.9	1.2	3.8					
40	2.8	0.4	0.4	1.0	1.4	1.0	2.2							
60	4.1	0.4	0.4	0.7	1.4									
80	5.5	0.4	0.3	0.6	1.3									
100	6.9	0.4	0.3	0.4	1.4									
125	8.6	0.4	0.3											
150	10.3	0.4	0.3											
175	12.1	0.4	0.3											
200	13.8	0.4	0.3											

Shaded areas indicate where maximum operating inlet pressure for a given orifice size is exceeded.

- continued -

**Table 12. C<sub>v</sub> Coefficient of T205 Series with 1 in. / DN 25 Body Size**

SPRING RANGE AND COLOR	OUTLET PRESSURE SETTING	OFFSET FROM SETPOINT	INLET PRESSURE		C <sub>v</sub> COEFFICIENT										
					Orifice Size, In. / mm										
					1/8 / 3.2		1/4 / 6.4		3/8 / 9.5		1/2 / 13		9/16 / 14		
					Type										
		psig	bar	T205	T205M	T205	T205M	T205	T205M	T205	T205M	T205	T205M		
2.5 to 7 in. w.c. / 6.2 to 17 mbar Red	2.5 in. w.c. / 6.2 mbar	-1 to 2 in. w.c. / -2.5 to 5.0 mbar	1	0.07	0.4	0.4	1.0	1.2	1.8	1.2	2.4	2.0	2.4	1.8	
			2	0.14	0.4	0.4	1.1	0.9	1.6	1.3	3.1	2.2	2.6	2.0	
			5	0.34	0.4	0.4	1.1	0.8	2.4	1.3	3.9	2.1	4.7	2.5	
			10	0.69	0.4	0.4	1.3	1.1	2.6	1.3	4.2	1.8	3.1	1.9	
			15	1.0	0.4	0.4	1.4	1.0	2.6	1.1	2.3	2.0	2.2	1.3	
			20	1.4	0.3	0.3	1.4	0.9	2.6	1.1	1.9	2.1			
			30	2.1	0.4	0.4	1.4	1.0	1.5	1.2	1.3	1.7			
			40	2.8	0.4	0.4	1.2	0.8	1.2	0.9	1.0	1.4			
			60	4.1	0.4	0.3	0.8	0.8	1.2	1.0					
			80	5.5	0.4	0.3	0.5	0.8	0.7	2.8					
	100	6.9	0.3	0.3	0.4	0.5									
	125	8.6	0.3	0.3	0.4	1.3									
	150	10.3	0.3	0.3	0.3	1.4									
	175	12.1	0.4	0.3											
	200	13.8	0.4	0.3											
7 to 16 in. w.c. / 17 to 40 mbar Unpainted	4 in. w.c. / 10 mbar	-1 to 2 in. w.c. / -2.5 to 5.0 mbar	1	0.07	0.5	0.4	1.1	1.0	1.5	1.3	1.7	1.5	2.0	1.6	
			2	0.14	0.3	0.4	1.0	0.9	1.3	0.9	2.0	1.4	2.1	1.9	
			5	0.34	0.4	0.4	0.9	0.6	2.0	1.0	3.8	1.5	4.7	1.8	
			10	0.69	0.4	0.4	1.1	0.9	2.4	1.0	4.3	1.5	4.5	1.7	
			15	1.0	0.4	0.3	1.3	0.7	2.6	0.9	3.7	1.3	2.8	1.4	
			20	1.4	0.4	0.3	1.4	0.8	2.5	1.0	1.9	1.5			
			30	2.1	0.4	0.3	1.4	0.6	2.6	0.9	1.3	1.4			
			40	2.8	0.4	0.3	1.4	0.7	2.7	0.8	1.0	0.7			
			60	4.1	0.3	0.3	0.8	0.6	1.6	0.6					
			80	5.5	0.4	0.3	0.6	0.7	0.8	0.5					
	100	6.9	0.4	0.3	0.4	0.4									
	125	8.6	0.4	0.3	0.4	0.8									
	150	10.3	0.4	0.3	0.3	0.6									
	175	12.1	0.3	0.3											
	200	13.8	0.3	0.3											

Shaded areas indicate where maximum operating inlet pressure for a given orifice size is exceeded.

- continued -

# T205 Series

**Table 12. C<sub>v</sub> Coefficient of T205 Series with 1 in. / DN 25 Body Size (continued)**

SPRING RANGE AND COLOR	OUTLET PRESSURE SETTING	OFFSET FROM SETPOINT	INLET PRESSURE		C <sub>v</sub> COEFFICIENT									
					Orifice Size, In. / mm									
					1/8 / 3.2		1/4 / 6.4		3/8 / 9.5		1/2 / 13		9/16 / 14	
					Type									
		psig	bar	T205	T205M	T205	T205M	T205	T205M	T205	T205M	T205	T205M	
7 to 16 in. w.c. / 17 to 40 mbar  Unpainted	12 in. w.c. / 30 mbar	20% Gauge	1	0.07	0.5	0.4	1.4	1.0	1.2	1.6	2.4	2.3	2.7	2.7
			2	0.14	0.4	0.4	0.9	0.9	1.3	1.4	2.3	1.6	2.4	2.4
			5	0.34	0.4	0.4	1.0	0.8	1.5	1.4	2.5	1.9	2.9	2.2
			8	0.55	0.4	0.4	1.1	0.8	2.0	1.5	4.2	2.0	4.8	2.3
			20	1.4	0.4	0.3	1.3	0.9	2.1	1.3	2.2	2.2	2.1	2.0
			35	2.4	0.4	0.4	1.4	0.9	2.3	1.3	1.2	1.6	1.1	2.2
			60	4.1	0.4	0.3	0.9	0.9	1.2	1.0	0.8	1.5	0.6	1.8
			75	5.2	0.4	0.3	0.7	0.9	0.9	1.1	0.6	1.5	0.5	1.4
			100	6.9	0.4	0.3	0.5	0.7	0.5	0.9	0.4	1.5	0.3	1.3
			125	8.6	0.4	0.3	0.5	1.0	0.3	1.4	0.3	1.0	Shaded	
	150	10.3	0.4	0.3	0.3	1.0	0.2	1.2	Shaded					
	175	12.1	0.4	0.3	Shaded									
	200	13.8	0.4	0.3										
	16 in. w.c. / 40 mbar	20% Gauge	1	0.07	0.5	0.5	1.5	1.2	1.6	1.8	2.8	2.6	2.7	3.3
			2	0.14	0.4	0.4	1.0	1.0	1.3	1.5	2.5	1.7	3.0	2.6
			5	0.34	0.4	0.4	1.1	0.9	1.8	1.7	2.6	2.2	3.2	2.6
			8	0.55	0.4	0.4	1.1	0.9	2.1	1.7	4.0	2.2	4.7	2.6
			20	1.4	0.4	0.3	1.2	1.1	2.4	1.6	4.8	2.6	5.3	2.5
			35	2.4	0.4	0.3	1.3	1.0	2.1	1.6	1.4	1.9	1.3	2.2
			60	4.1	0.4	0.3	1.0	1.0	2.7	1.4	1.0	1.9	0.8	2.3
75			5.2	0.4	0.3	0.7	1.0	1.0	1.4	0.7	1.6	0.6	2.4	
100			6.9	0.4	0.3	0.5	0.9	0.5	1.5	0.5	1.5	0.5	1.2	
125			8.6	0.4	0.3	0.5	1.1	0.3	1.5	0.4	1.0	Shaded		
150	10.3	0.3	0.3	0.4	1.2	0.3	1.4	Shaded						
175	12.1	0.3	0.3	Shaded										
200	13.8	0.3	0.3											
0.5 to 1.2 psig / 34 to 83 mbar  Yellow	0.58 psi / 40 mbar	20% Gauge	2	0.14	0.4	0.4	1.1	1.1	1.5	1.6	2.1	2.0	2.4	2.0
			6	0.41	0.4	0.4	0.9	0.7	1.4	1.3	2.4	1.8	2.8	2.2
			10	0.69	0.3	0.4	1.0	0.9	1.6	1.3	3.3	1.8	4.9	2.2
			30	2.1	0.4	0.3	1.3	0.9	2.7	1.2	1.9	1.7	1.5	1.9
			45	3.1	0.4	0.3	1.2	0.9	2.0	1.1	1.4	1.8	1.2	1.2
			60	4.1	0.4	0.3	1.4	0.8	1.5	1.1	0.9	2.1	0.8	1.7
			80	5.5	0.4	0.4	1.1	0.8	0.8	1.1	0.6	1.8	0.6	1.6
			100	6.9	0.4	0.3	0.9	0.8	0.6	1.3	0.5	1.4	0.4	1.5
			125	8.6	0.3	0.3	0.6	1.0	0.3	1.3	0.4	1.2	0.4	1.5
			150	10.3	0.3	0.3	0.4	0.9	0.2	1.3	0.2	1.4	Shaded	
	175	12.1	0.3	0.3	Shaded									
	200	13.8	0.3	0.3										
	1 psi / 69 mbar	20% Gauge	2	0.14	0.5	0.4	1.2	1.3	1.7	2.2	2.7	2.8	3.2	2.5
			6	0.41	0.3	0.4	1.2	1.1	1.7	1.8	2.9	2.5	3.3	2.9
			10	0.69	0.4	0.4	1.2	1.1	1.9	1.9	3.4	2.5	4.4	2.7
			30	2.1	0.3	0.3	1.3	1.2	2.7	1.7	3.4	2.2	2.2	2.3
			60	4.1	0.4	0.4	1.4	1.1	1.5	1.7	1.4	2.1	1.1	1.5
			80	5.5	0.3	0.4	1.4	1.0	1.0	1.5	1.0	2.0	0.8	1.4
			100	6.9	0.4	0.3	1.0	1.2	0.9	2.1	0.8	2.5	0.8	2.1
			125	8.6	0.3	0.3	0.7	1.1	0.7	1.7	0.5	2.0	0.5	2.4
150			10.3	0.3	0.3	0.6	1.1	Shaded		1.7	0.5	1.9	Shaded	
175			12.1	0.3	0.3	Shaded								
200	13.8	0.3	0.3											

Shaded areas indicate where maximum operating inlet pressure for a given orifice size is exceeded.

- continued -

**Table 12. C<sub>v</sub> Coefficient of T205 Series with 1 in. / DN 25 Body Size (continued)**

SPRING RANGE AND COLOR	OUTLET PRESSURE SETTING	OFFSET FROM SETPOINT	INLET PRESSURE		C <sub>v</sub> COEFFICIENT									
					Orifice Size, In. / mm									
					1/8 / 3.2		1/4 / 6.4		3/8 / 9.5		1/2 / 13		9/16 / 14	
					Type									
		psig	bar	T205	T205M	T205	T205M	T205	T205M	T205	T205M	T205	T205M	
1.2 to 2.5 psig / 83 to 172 mbar  Green	1.2 psi / 83 mbar	20% Gauge	4	0.28	0.3	0.3	0.8	0.9	1.0	0.9	1.3	1.5	1.8	1.6
			8	0.55	0.3	0.3	0.8	0.6	1.0	0.9	1.6	1.4	1.9	1.6
			12	0.83	0.3	0.3	0.8	0.7	1.1	1.0	1.7	1.4	2.1	1.6
			30	2.1	0.3	0.3	0.9	0.7	1.3	0.9	1.4	1.3	5.4	1.5
			60	4.1	0.3	0.3	1.2	0.7	2.8	0.9	1.6	1.3	1.6	1.4
			80	5.5	0.3	0.3	1.3	0.6	1.5	0.9	1.2	1.4	1.0	1.4
			100	6.9	0.3	0.3	1.4	0.7	1.0	0.8	1.0	1.3	0.9	1.4
			125	8.6	0.4	0.3	1.1	0.6	0.9	0.8	0.7	1.2	0.7	1.3
			150	10.3	0.3	0.3	0.9	0.7	0.9	1.1	0.6	1.3	0.6	0.9
			175	12.1	0.3	0.3	0.4	0.6	0.6	1.0	0.5	1.2	0.6	1.0
	200	13.8	0.3	0.3	0.3	0.6	0.4	0.9	0.4	1.0	0.4	0.7		
	2.5 psi / 0.17 bar	20% Gauge	6	0.41	0.4	0.4	1.1	1.1	1.7	1.7	2.4	2.2	2.6	2.5
			10	0.69	0.4	0.3	1.1	0.9	1.6	1.6	2.3	2.1	2.6	2.6
			30	2.1	0.4	0.3	1.0	1.0	1.9	1.5	4.0	1.9	5.3	2.5
			60	4.1	0.4	0.3	1.3	1.0	2.7	1.3	2.4	2.3	2.3	2.1
			80	5.5	0.4	0.3	1.4	0.9	2.7	1.4	1.7	2.3	1.7	2.5
			100	6.9	0.4	0.3	1.4	1.0	1.2	1.3	1.3	2.2	1.4	2.3
			125	8.6	0.3	0.3	1.4	0.9	1.0	1.4	1.0	2.2	1.1	2.3
			150	10.3	0.3	0.4	1.2	1.0	1.2	1.5	0.9	1.9	0.8	2.2
			175	12.1	0.3	0.3	1.0	0.9	1.0	1.5	0.7	2.0	0.7	2.2
200			13.8	0.3	0.3	1.0	0.9	0.8	1.6	0.6	1.9	0.6	1.8	
2.5 to 4.5 psig / 0.17 to 0.31 bar  Light blue	2.5 psi / 0.17 bar	20% Gauge	4	0.28	0.4	0.4	0.9	0.9	1.1	1.1	1.8	1.6	1.8	1.7
			8	0.55	0.3	0.4	0.6	0.5	1.0	1.0	1.6	1.4	1.8	1.7
			12	0.83	0.3	0.3	0.7	0.7	1.0	1.0	1.6	1.4	1.8	1.5
			30	2.1	0.3	0.3	0.7	0.7	1.1	0.9	1.5	1.3	2.8	1.5
			60	4.1	0.3	0.3	0.8	0.6	1.4	0.9	4.8	1.1	5.3	1.3
			80	5.5	0.3	0.3	1.0	0.7	2.8	0.9	1.8	1.2	1.9	1.3
			100	6.9	0.3	0.3	1.2	0.7	1.9	0.8	1.4	1.2	1.4	1.5
			125	8.6	0.3	0.3	1.4	0.7	1.1	0.8	1.1	1.2	1.2	1.1
			150	10.3	0.3	0.3	1.4	0.7	1.3	1.0	1.0	1.1	1.0	1.4
			175	12.1	0.3	0.3	1.2	0.7	1.1	0.9	0.8	1.2	0.8	1.5
	200	13.8	0.3	0.3	1.0	0.6	0.9	1.0	0.7	1.3	0.6	1.4		
	4.5 psi / 0.31 bar	20% Gauge	8	0.55	0.4	0.4	1.0	0.9	1.5	1.5	2.4	2.1	2.4	2.2
			12	0.83	0.4	0.4	0.9	0.7	1.4	1.4	2.2	1.9	2.3	2.0
			30	2.1	0.4	0.4	0.9	0.9	1.4	1.4	2.3	1.9	3.1	2.1
			60	4.1	0.4	0.4	1.0	0.9	2.1	1.4	4.6	1.7	5.5	2.0
			80	5.5	0.3	0.4	1.1	0.9	2.7	1.3	4.9	1.9	5.7	2.0
			100	6.9	0.4	0.3	1.3	0.9	2.7	1.4	2.2	1.9	2.2	2.2
			125	8.6	0.3	0.4	1.4	0.9	2.7	1.4	1.6	1.8	1.7	2.2
			150	10.3	0.3	0.3	1.4	0.9	1.6	1.4	1.3	1.9	1.5	2.2
			175	12.1	0.3	0.3	1.4	0.9	13.5	1.6	1.2	1.8	1.2	1.9
200			13.8	0.3	0.3	1.4	0.9	1.2	1.4	1.0	1.8	1.1	2.0	
4.5 to 7 psig / 0.31 to 0.48 bar  Black	4.5 psi / 0.31 bar	20% Gauge	9	0.62	0.3	0.3	0.7	0.5	1.1	1.1	1.6	1.4	1.8	1.5
			12	0.83	0.3	0.3	0.7	0.6	1.1	1.0	1.5	1.4	1.7	1.6
			30	2.1	0.3	0.3	0.7	0.7	1.0	1.0	1.5	1.3	1.9	1.5
			60	4.1	0.2	0.3	0.7	0.7	1.2	1.0	3.7	1.3	4.6	1.4
			80	5.5	0.3	0.3	0.8	0.7	2.2	0.9	4.5	1.2	5.3	1.3
			100	6.9	0.3	0.3	0.9	0.7	2.6	0.9	2.8	1.4	5.4	1.3
			125	8.6	0.3	0.3	1.1	0.7	2.7	0.8	1.8	1.2	1.9	1.4
			150	10.3	0.3	0.3	1.3	0.7	2.1	1.0	1.5	1.3	1.6	1.3
			175	12.1	0.3	0.3	1.4	0.7	1.5	1.0	1.3	1.2	1.3	1.4
			200	13.8	0.3	0.3	1.4	0.6	1.3	1.0	1.1	1.1	1.2	1.2
	7 psi / 0.48 bar	20% Gauge	9	0.62	0.4	0.5	1.1	1.2	1.7	1.5	2.3	2.3	2.7	2.4
			12	0.83	0.4	0.4	0.9	0.7	1.4	1.1	2.1	2.0	2.4	2.2
			30	2.1	0.3	0.3	0.9	0.9	1.3	1.3	2.0	1.9	2.5	2.0
			60	4.1	0.3	0.3	0.9	0.8	1.5	1.2	3.5	1.9	4.5	2.1
			80	5.5	0.3	0.3	1.0	0.9	2.1	1.2	4.5	1.8	5.3	1.9
			100	6.9	0.3	0.3	1.0	0.9	2.4	1.0	4.7	1.6	5.3	1.8
			125	8.6	0.3	0.3	1.2	0.9	2.7	1.2	4.7	1.6	5.3	1.9
			150	10.3	0.4	0.3	1.3	0.8	2.8	1.3	2.0	1.8	2.1	2.1
			175	12.1	0.3	0.3	1.3	0.9	2.8	1.3	1.9	1.7	1.8	1.9
			200	13.8	0.3	0.3	1.3	0.8	1.8	1.3	1.6	1.7	1.3	1.9

# T205 Series

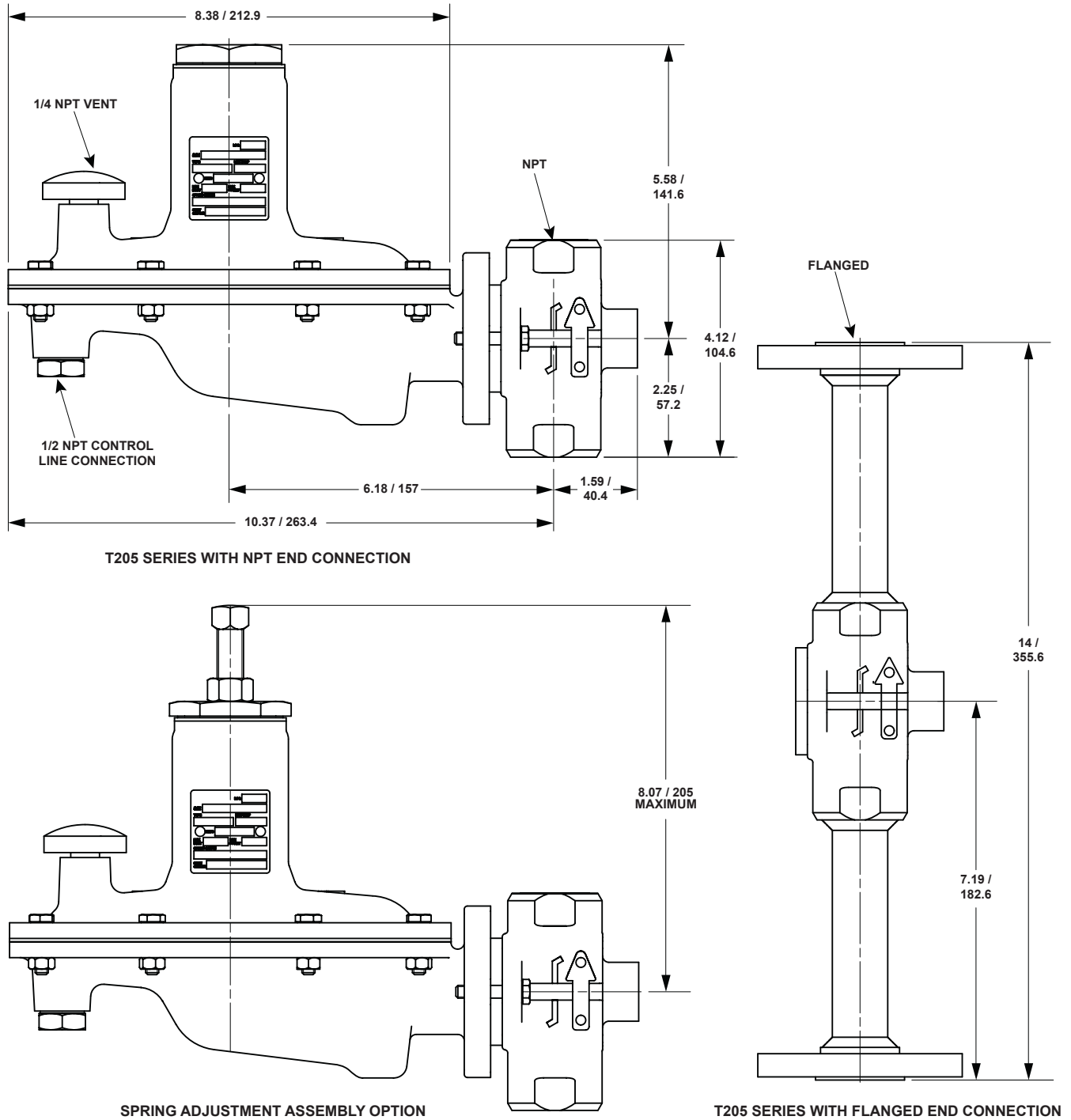

IN. / mm

Figure 6. Dimensions

## Ordering Information

When ordering, complete the ordering guide on this page. Refer to the Specifications section on page 2. Review the description to the right of each specification and the

information in each referenced table or figure. Specify your choice whenever a selection is offered.

## Ordering Guide

### Type (Select One)

- T205, Internal pressure registration
- T205H, Internal pressure registration with equal inlet and outlet pressure rating
- T205M, External pressure registration
- T205HM, External pressure registration with equal inlet and outlet pressure rating

### Body Size (Select One)

- 3/4 in. / DN 20\*\*\*
- 1 in. / DN 25\*\*\*

### Body Material and End Connection Style (Select One)

#### Gray cast iron

- NPT\*\*\*

#### WCC Carbon steel

- NPT\*\*\*
- CL150 RF\*\*
- CL300 RF\*
- PN 16/25/40 RF\*, please specify rating\_\_\_\_\_

#### LCC Carbon steel

- NPT\*\*
- CL150\*
- CL300\*
- PN 16/25/40 RF\*, please specify rating\_\_\_\_\_

#### CF8M/CF3M Stainless steel

- NPT\*\*\*
- CL150 RF\*\*
- CL300 RF\*
- PN 16/25/40 RF\*, please specify rating\_\_\_\_\_

### Outlet (Control) Pressure Range (Select One)

- 1 to 2.5 in. w.c. / 2.5 to 6.2 mbar, Orange\*\*\*
- 2.5 to 7 in. w.c. / 6.2 to 17 mbar, Red\*\*\*
- 7 to 16 in. w.c. / 17 to 40 mbar, Unpainted\*\*\*
- 0.5 to 1.2 psig / 34 to 83 mbar, Yellow\*\*\*
- 1.2 to 2.5 psig / 83 to 172 mbar, Green\*\*
- 2.5 to 4.5 psig / 0.17 to 0.31 bar, Light Blue\*\*
- 4.5 to 7 psig / 0.31 to 0.48 bar, Black\*\*

### Orifice Size (Select One)

- 1/8 in. / 3.2 mm\*\*\*
- 1/4 in. / 6.4 mm\*\*\*
- 3/8 in. / 9.5 mm\*\*\*
- 1/2 in. / 13 mm\*\*
- 9/16 in. / 14 mm\*

### 316 Stainless Steel Trim Parts (Select One)

- Yes
- No

### Trim Material (See Table 4, Select One)

- Standard
- EE
- FDA
- VV
- TN
- TV
- TK
- TE

### Adjusting Screw (Select One)

- Internal Flat Circular (**standard**)\*\*\*
- External Square Head (Available for Green, Light Blue and Black springs only. Steel closing cap is automatically supplied in this option)\*\*\*

### Closing Cap Material (Select One)

- Plastic (**standard**) (not available for Green, Light Blue and Black springs)\*\*\*
- Steel (**standard** for Green, Light Blue and Black springs)\*\*\*
- Stainless steel\*\*

### Body Position (See Figure 5, Select One)

- Position 1 (**standard**)\*\*\*
- Position 2\*\*\*
- Position 3\*\*\*
- Position 4\*\*\*

### Spring Case Orientation/Vent Type (Select One)

- Spring Case Sideways (Type Y602-12) (**standard**)
- Spring Case Down (Type Y602-1)
- Spring Case Up (Type Y602-11)

### Vent Orientation (See Figure 5, Select One)

- Position A (**standard**)\*\*\*
- Position B\*\*\*
- Position C\*\*\*
- Position D\*\*\*

### NACE Standard MR0175-2002 Construction (Select One)

- Yes
- No

### Replacement Parts Kit (Optional)

- Yes, send one replacement parts kit to match this order.

- continued -

# T205 Series

## Ordering Guide (continued)

Regulators Quick Order Guide	
***	Readily Available for Shipment
**	Allow Additional Time for Shipment
*	Special Order, Constructed from Non-Stocked Parts. Consult your local Sales Office for Availability.
Availability of the product being ordered is determined by the component with the longest shipping time for the requested construction.	

Specification Worksheet	
<b>Application:</b>	
Specific Use	_____
Line Size	_____
Fluid Type	_____
Specific Gravity	_____
Temperature	_____
Does the Application Require Overpressure Protection?	
<input type="checkbox"/> Yes	<input type="checkbox"/> No
<b>Pressure:</b>	
Maximum Inlet Pressure	_____
Minimum Inlet Pressure	_____
Differential Pressure	_____
Set Pressure	_____
Maximum Flow	_____
<b>Accuracy Requirements:</b>	
Less Than or Equal To:	
<input type="checkbox"/> 5%	<input type="checkbox"/> 10% <input type="checkbox"/> 20% <input type="checkbox"/> Wide-Open
<b>Construction Material Requirements (if known):</b>	
_____	
_____	

 [Webadmin.Regulators@emerson.com](mailto:Webadmin.Regulators@emerson.com)

 [Facebook.com/EmersonAutomationSolutions](https://www.facebook.com/EmersonAutomationSolutions)

 [Fisher.com](http://Fisher.com)

 [LinkedIn.com/company/emerson-automation-solutions](https://www.linkedin.com/company/emerson-automation-solutions)

 [Twitter.com/emr\\_automation](https://twitter.com/emr_automation)

### Emerson Automation Solutions

#### Americas

McKinney, Texas 75070 USA  
T +1 800 558 5853  
+1 972 548 3574

#### Europe

Bologna 40013, Italy  
T +39 051 419 0611

#### Asia Pacific

Singapore 128461, Singapore  
T +65 6777 8211

#### Middle East and Africa

Dubai, United Arab Emirates  
T +971 4 811 8100

D103747X012 © 2013, 2022 Emerson Process Management Regulator Technologies, Inc. All rights reserved. 03/22.

The Emerson logo is a trademark and service mark of Emerson Electric Co. All other marks are the property of their prospective owners. Fisher™ is a mark owned by Fisher Controls International LLC, a business of Emerson Automation Solutions.

The contents of this publication are presented for informational purposes only, and while every effort has been made to ensure their accuracy, they are not to be construed as warranties or guarantees, express or implied, regarding the products or services described herein or their use or applicability. All sales are governed by our terms and conditions, which are available upon request. We reserve the right to modify or improve the designs or specifications of such products at any time without notice.

Emerson Process Management Regulator Technologies, Inc does not assume responsibility for the selection, use or maintenance of any product. Responsibility for proper selection, use and maintenance of any Emerson Process Management Regulator Technologies, Inc. product remains solely with the purchaser.



The distinctive diamond shape cast into every spring case uniquely identifies the regulator as part of the Fisher™ brand and assures you of the highest-quality engineering, durability, performance, and support.

