

Commercial Service Reliability



FISHER™ CS400 Series

The Fisher™ CS400 Series

The CS400 Series direct-operated, spring-loaded regulators have been engineered to fit a multitude of pressure-reducing applications including commercial and light industrial installations. This flexibility is provided by the numerous body sizes and end connections, outlet pressure settings, orifice sizes and the option for internal or external pressure registration. The CS400 Series also offers multiple overpressure protection options, which include Internal relief, Integral True-Monitor™ Protection and Slam-Shut Protection.

Product Advantages

- Higher capacities, up to 7.5M BTU LP-Gas
- New Technologies in overpressure protection
- Inlet and outlet gauge taps
- Improved corrosion resistance
- Internal or external pressure registration
- Wide variety of body sizes and end connections

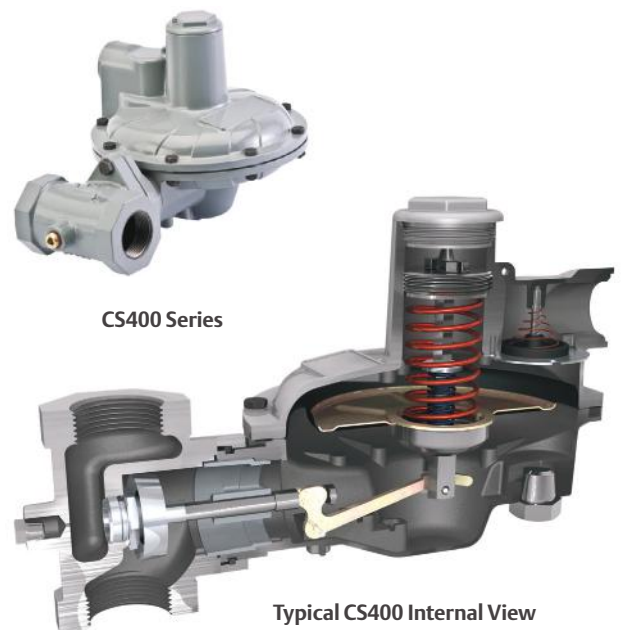

Overpressure Protection Options

INTEGRAL MONITOR

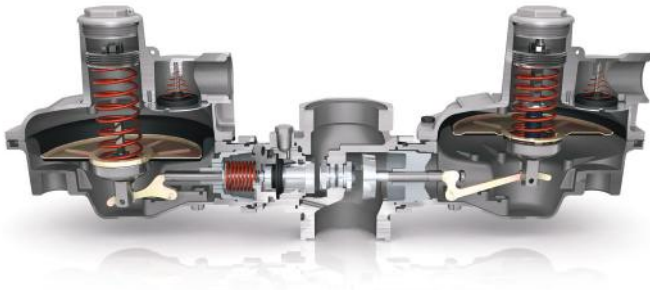

PRIMARY REGULATOR



Integral True-Monitor™ Protection

Combines the operation of a conventional two regulator wide-open monitor set into one device without the need for a downstream control line.

Internal Relief

Discharges gas across the diaphragm assembly to minimize overpressure.



Slam-Shut

Shuts off gas service to the downstream system in the event of an overpressure or underpressure condition.

CS400 Series Features

- **Operation:** Direct-Operated, Spring-Loaded
- **Body Size:** NPS 1-1/4, 1-1/2, 2, NPT, ISO 7/1 Rp; NPS 2 / DN 50, CL125 FF / CL150 FF, PN 10/16
- **Maximum Operating Inlet Pressure:** Up to 125 psig / 8.6 bar
- **Outlet Pressure Range:** 3.5 in. w.c. to 5.5 psig / 9 mbar to 0.38 bar
- **Maximum Outlet (Casing) Pressure:** 25 psig / 1.7 bar
- **Temperature Capabilities:** -20 to 150°F / -29 to 66°C
- **Spring Case Vent Connection:** 1 NPT
- **Pressure Registration:** Internal or External
- **Body Material:** Gray Cast Iron, Ductile Cast Iron and Steel
- **Overpressure Protection:**
 - Internal Relief
 - Integral True-Monitor Protection
 - Slam-Shut Protection

Emerson Automation Solutions

Americas

T +1 800 558 5853
T +1 972 548 3574

✉ webadmin.regulators@emerson.com

🌐 Fisher.com

Europe

T +39 051 419 0611

📘 Facebook.com/EmersonAutomationSolutions

Asia Pacific

T +65 6777 8211

🌐 LinkedIn.com/company/emerson-automation-solutions

🐦 Twitter.com/emr_automation

Middle East / Africa

T +971 4811 8100