

Fisher™ Commercial Service Reliability



FISHER™ CS200 Series

The Fisher CS200 Series

The CS200 Series direct-operated, spring-loaded regulators have been engineered to fit a multitude of pressure-reducing applications including commercial and light industrial installations. This flexibility is provided by the numerous body sizes, outlet pressure settings and orifice sizes. Ease of maintenance and installation is also a strength of the CS200 Series, which offers the combination of 360 degree rotatable union ring along with a rotatable upper casing that provides simplified vent positioning, especially in tight spaces or awkward installations.

To provide further flexibility, the CS200 Series offers optional overpressure protection via Internal Relief or Secondary Seat™ Protection.

By relieving gas through the diaphragm assembly to atmosphere, the Internal Relief valve minimizes downstream pressure build-up in the event of an overpressure situation.

Secondary Seat Protection provides shutoff in the event that the primary orifice seating surface or disk surface becomes damaged or obstructed by debris and can no longer provide shutoff.



CS200 Series

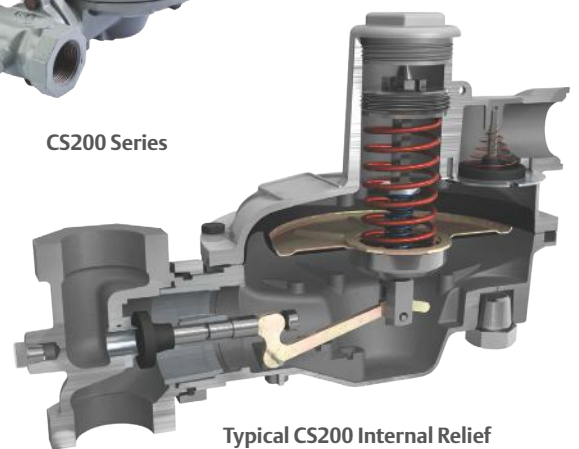

Typical CS200 Internal Relief



Optional Secondary Seat™ Protection

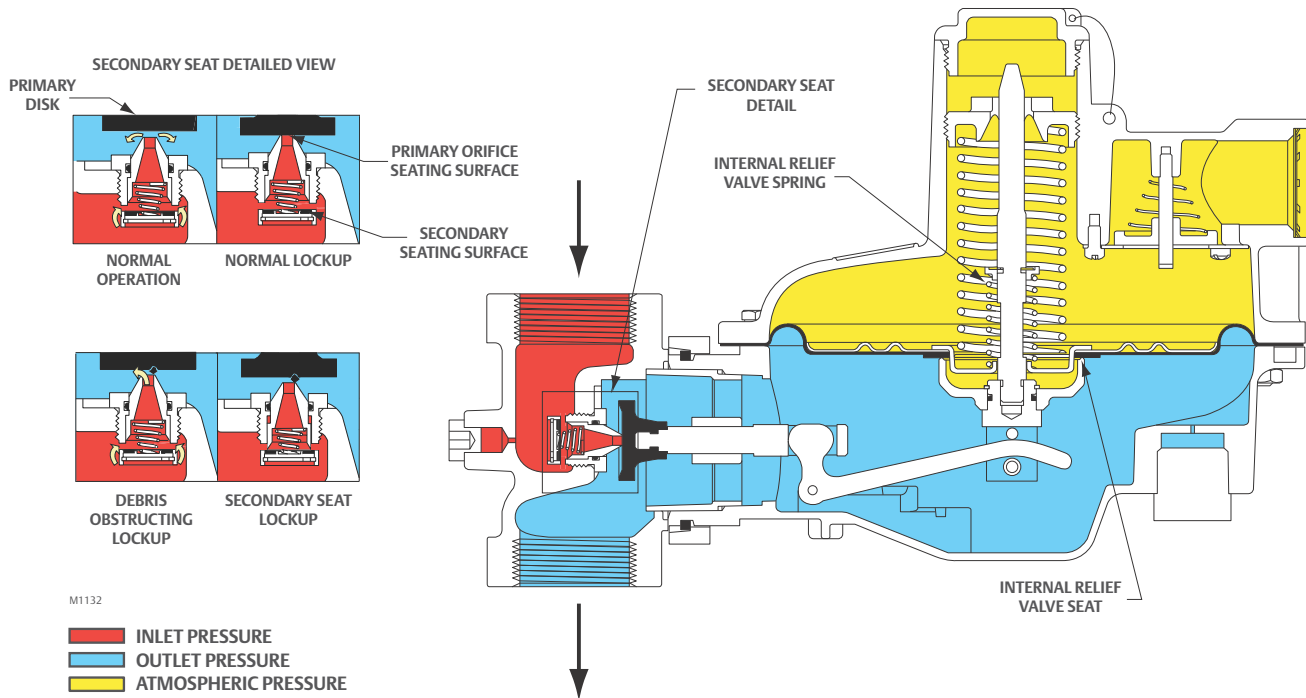

Product Advantages

- Internal registration provides compact installation
- Wide range of NPT body sizes
- Platform breadth and application coverage
- Multiple Overpressure Protection Options:
 - Internal Relief
 - Secondary Seat Protection
 - Secondary Seat Protection with bleed

CS200 Series Features

- **Operation:** Direct-Operated, Spring-Loaded
- **Body Size:** 3/4, 3/4 x 1, 3/4 x 1-1/4, 1, 1 x 1-1/4 and 1-1/4 NPT
- **Maximum Inlet Pressure:** Up to 175 psig / 12.1 bar
- **Outlet Pressure Range:** 3.5 in. w.c. to 2.0 psig / 9 to 138 mbar
- **Maximum Outlet (Casing) Pressure:** 25 psig / 1.7 bar
- **Temperature Capabilities:** -20 to 150°F / -29 to 66°C
- **Spring Case Vent Connection:** 1 NPT
- **Pressure Registration:** Internal
- **Body Material:** Gray Cast Iron
- **Overpressure Protection:**
 - Internal Relief
 - Secondary Seat Protection

Emerson Automation Solutions

Americas

T +1 800 558 5853
T +1 972 548 3574

Europe

T +39 051 419 0611

Asia Pacific

T +65 6777 8211

Middle East / Africa

T +971 4811 8100

- ✉ webadmin.regulators@emerson.com
- 🔍 Fisher.com
- 📘 Facebook.com/EmersonAutomationSolutions
- 🌐 LinkedIn.com/company/emerson-automation-solutions
- 🐦 Twitter.com/emr_automation



The distinctive swirl pattern cast into every actuator casing uniquely identifies the regulator as part of the Fisher™ brand Commercial Service Regulator family and assures you of the highest-quality engineering, performance, and support traditionally associated with Fisher™ and Tartarini™ regulators. Visit www.fishercommercialservice.com to access interactive applications.

