

RV4043/RV4044 Motorized Valves

PRODUCT SPECIFICATION SHEET



FEATURES

- RV4043 provides 2-position, straight-through control of water.
- RV4044 provides 2-position diverting control of water.
- Compact construction for easy installation.
- Manual opener for valve operation on power failure
- Valve returns to automatic position when power is restored.
- Motor can be replaced by removing one screw, without disturbing the valve body or draining the system.
- Complete power-head may be removed or replaced without breaking the line connections or draining system.
- All models can be installed without disassembling the valve.

Specifications

Models:

RV4043: line voltage, straight-through valves.

RV4044: line voltage, 2-position diverting valves.

Static Pressure Rating: 125 psi

Electrical Rating:

220V @ 0.042A, 120V @ 0.080A

Timing:

RV4043: Open or close in 15 seconds maximum.

RV4044: Divert flow in 30 seconds maximum.

Temperature ratings:

Maximum Fluid Temperature: 116°C

Minimum Fluid Temperature: 5°C

Ambient Temperature: 50°C

Manual Opener:

Manual opener (on all except the straight-through, normally open valves) allows opening the valve in case of power failure. Valve returns to automatic position when power is restored.

APPLICATION

These valves consist of an actuator motor and valve assembly for controlling the flow of hot or cold water.

IMPORTANT

These valves are not for use in systems containing dissolved oxygen.

SELECTION

OS#	2/3 way	Voltage (Vac)	Freq (Hz)	Size (in.)	Pipe Connection (Internal Thread)	Flow Capacity Cv	Max. Close-Off Pressure (psi)	Valve Action
RV4043C1347B	2	220	50	1/2"	BSPT	3.5	20	Normally Closed
RV4043C1354B	2	220	50	1/2"	Flare	3.5	20	Normally Closed
RV4043C1362B	2	220	50	3/4"	BSPP	8.0	8	Normally Closed
RV4043A1720B	2	220	50	3/4"	BSPP	3.5	20	Normally Closed
RV4044A1704B	3	220	50	3/4"	BSPT	7.0	10	Port A normally closed
RV4044C1668B	3	220	50	1/2"	BSPT	3.5	20	Port A normally closed

MOUNTING DIMENSIONS

RV4043 BSPP / BSPT MODELS

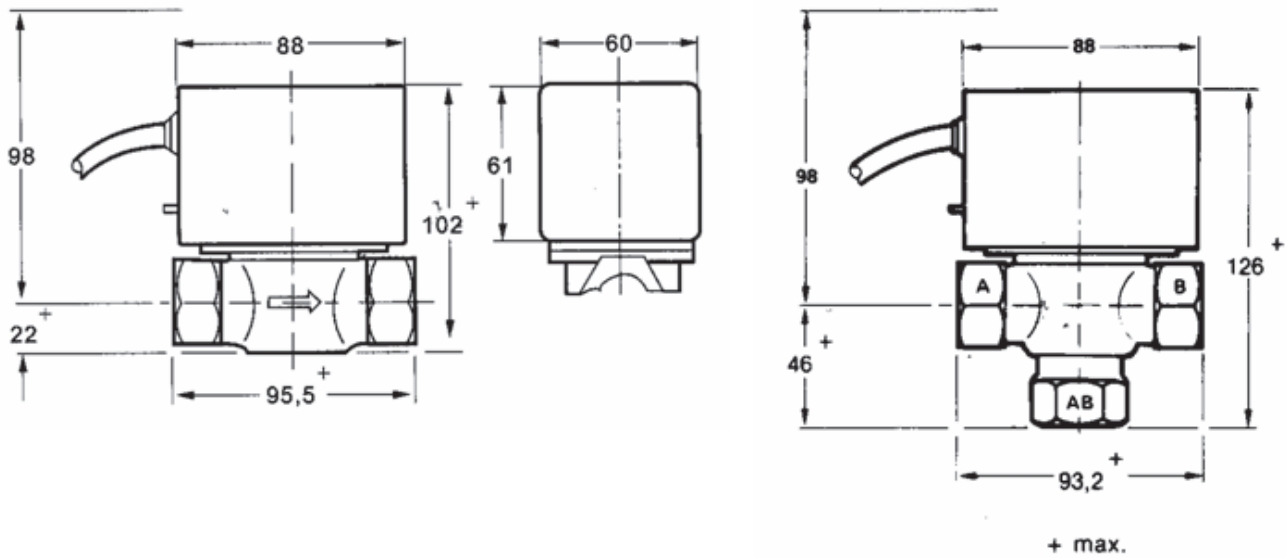

RV4043 FLARE-FITTING MODELS

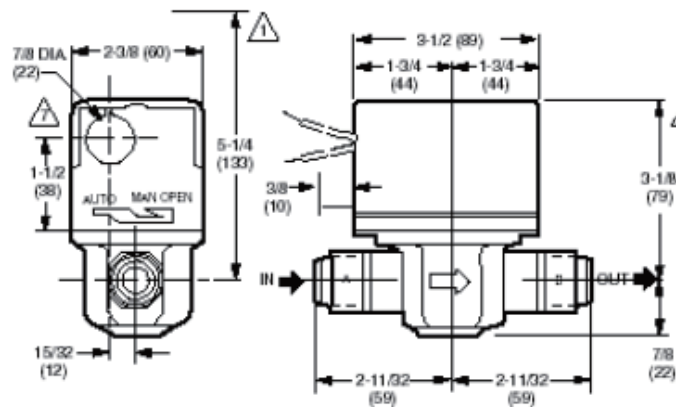

RV4044 FLARE-FITTING MODELS

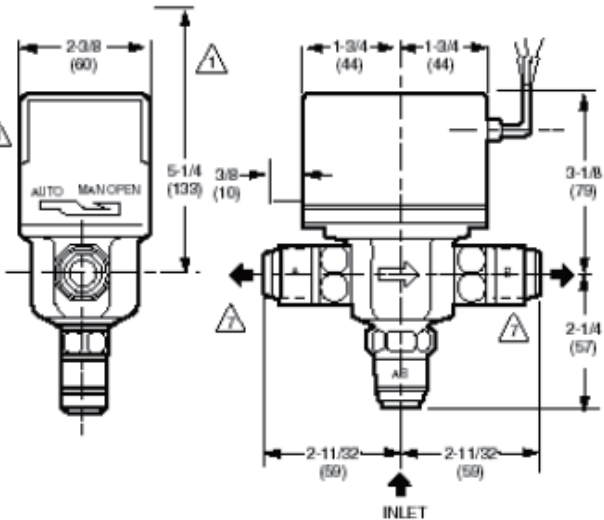

Fig. 1. Mounting dimensions in in. (mm) of RV4043 and RV4044 Motorized Valves

How to Find Maximum Valve Operating Temperature

The maximum operating temperature for motorized valves depends on the maximum ambient temperature at the valve location, and on the maximum fluid temperature. Using the graph in Fig. 2, find the maximum valve operating temperature as follows:

1. Measure the ambient temperature at the valve and locate that temperature on the ambient temperature scale on the graph.
2. Draw a line from the ambient temperature, parallel with the fluid temperature scale, to the maximum fluid temperature line.
3. Draw a line from that point down to the fluid temperature scale to find the maximum operating temperature. (Note the example shown by the dashed line in Fig. 2.)

To find the maximum ambient temperature for a valve when the fluid temperature is known, reverse the procedure.

How to Find Valve Pressure Drop

The pressure drop in psi (kPa), equivalent ft (m) of pipe, or feet of water (kPa) can be calculated from Fig. 3 through 8 as follows:

1. Calculate the flow rate to heat the zone.
2. Determine the Cv (Kv) rating of the motorized valve.
3. Select the graph corresponding to the Cv (Kv) rating (Fig. 3 through 5).
4. Determine the pressure drop across the valve using the following procedures for calculating pressure drop.

Pressure Drop in psi (kPa)

1. Locate the flow rate at the bottom of the graph.
2. Draw a line up from the flow rate to the intersection of the curve.
3. Draw a line from the intersection to the left edge of the graph to determine the pressure drop in psi (kPa).

Pressure Drop in Equivalent ft (m) of Pipe

NOTE: Both 1/2 and 3/4 in. pipe conversion scales are available for this determination.

1. Locate the flow rate at the bottom of the graph.
2. Draw a line vertically to the top of the graph. Determine the pressure drop for either the 1/2 or 3/4 in. pipe.

Pressure Drop in ft of Water (kPa)

1. Locate the flow rate at the bottom of the graph.
2. Draw a line up from the flow rate to the intersection of the curve.
3. Draw a line from the intersection to the right edge of the graph to determine pressure drop in ft of water (kPa).

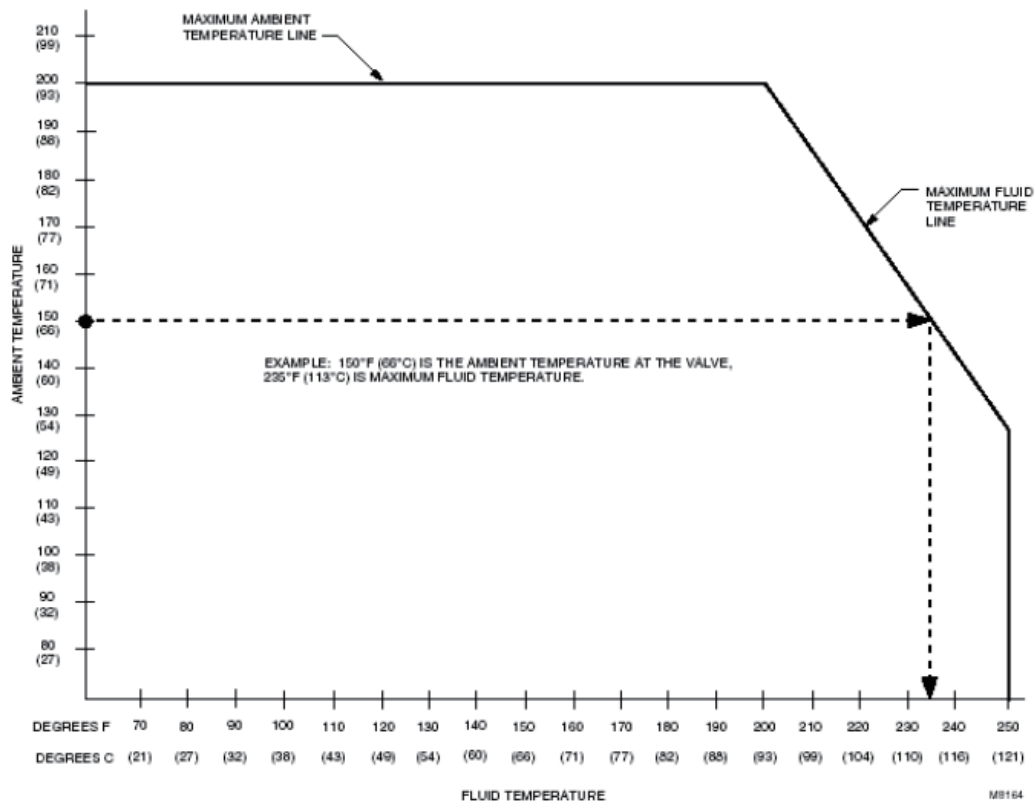

Fig. 2. Maximum temperature characteristics of valves with Class F motors

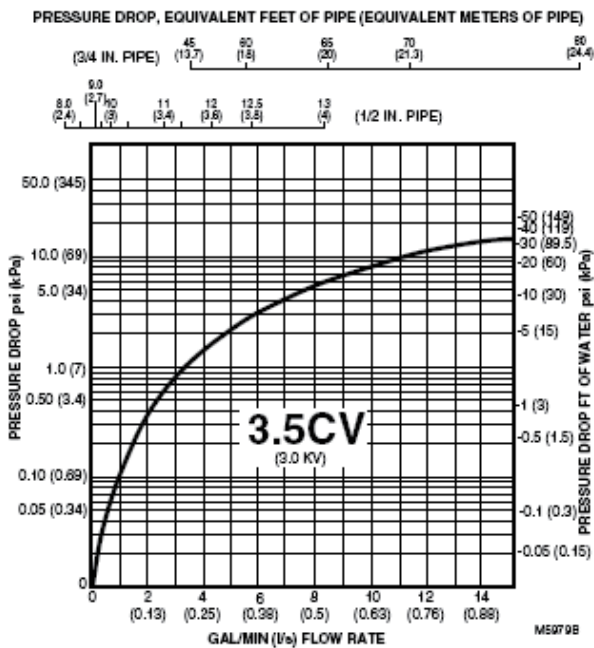

Fig. 3. Flow characteristics of 3.5 Cv (3.0 Kv) valve.

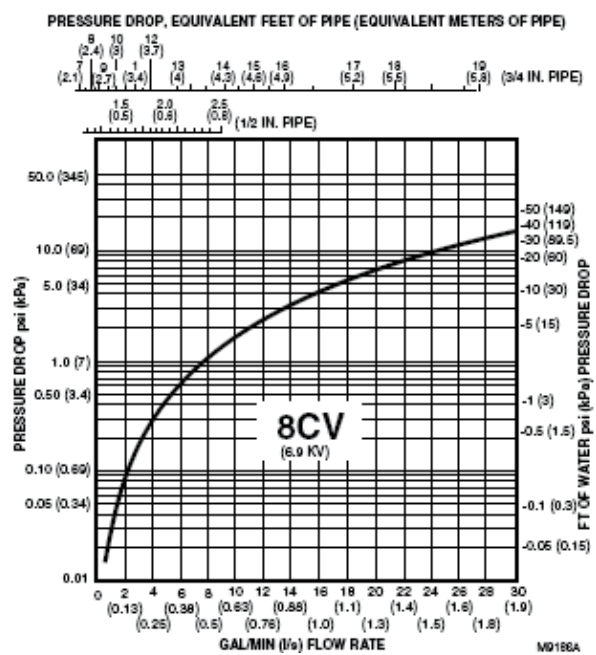

Fig. 5. Flow characteristics of 8 Cv (6.9 Kv) valve.

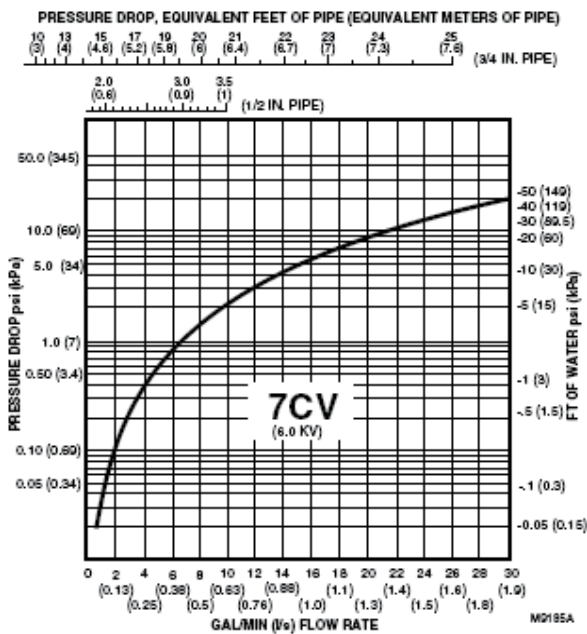

Fig. 4. Flow characteristics of 7 Cv (6.0 Kv) valve.

INSTALLATION

When Installing this Product...

1. Read these instructions carefully. Failure to follow them could damage the product or cause a hazardous condition.
2. Check the ratings given in the instructions and on the product to make sure the product is suitable for your application.
3. Installer must be a trained, experienced service technician.
4. After installation is complete, check out product operation as provided in these instructions.

CAUTION

1. Disconnect power supply before connecting wiring to prevent electrical shock or equipment damage.
2. Normally it is not necessary to remove the powerhead from the valve body during installation. If the valve must be disassembled, be certain that it is reassembled with the water flow in the direction of the arrow. Reversal of the powerhead results in damage to the gear train.
3. On 24V systems, never jumper the valve coil terminals even temporarily. This can burn out the heat anticipator in the thermostat.

IMPORTANT

Use this valve in hydronic heating systems that do not contain dissolved oxygen in the system water. The dissolved oxygen, which is found in systems that have a frequent source of makeup water, causes the rubber plug inside the valve to deteriorate and eventually fail.

Mounting

See Fig. 9. If the valve is mounted horizontally; the powerhead must be even with or above the center line of the piping. Make sure to leave enough room above the powerhead to remove the cover for servicing.

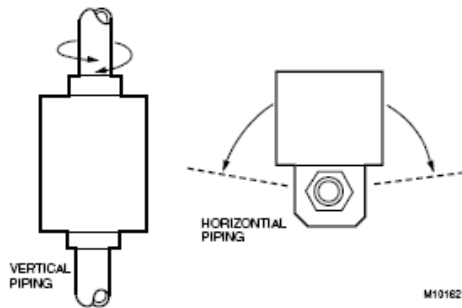

Fig. 6. Mounting positions.

Mount the valve directly in the tube or pipe. Make sure that the flow through the valve is in the direction indicated by the arrow stamped on the valve body.

On diverting valves, the three fittings or ports are labeled on the bottom of the valve body casting. Port AB is the inlet port and is open at all times. Port A is closed when the valve is de-energized; port B is open when the valve is de-energized. Refer to the equipment manufacturer instructions to determine which port (A or B) should be connected to the coil bypass.

Flare Fitting Models

Use new, properly reamed pipe, free from chips. The valve body is threaded for standard 5/8 in. OD copper, 45 degree SAE flare fitting nuts. These nuts are not furnished with the valve and must be obtained separately.

OPERATION AND CHECKOUT

CAUTION

On 24V systems, never jumper the valve coil terminals even temporarily. This can burn out the heat anticipator in the thermostat.

Operation

Automatic Operation

On a call for heat by the zone thermostat, the valve opens and its auxiliary switch contacts make, closing the circuit to the system circulator. In a multizone system with all the valve auxiliary switches wired in parallel, any zone calling for heat can operate the circulator. When the call for heat ends, the valve closes by integral spring return. The auxiliary switch contacts break the circulator circuit.

Manual Operation

The motorized valve can be opened manually by lifting the manual opening lever over the stop and pushing slowly and firmly to the MAN. OPEN position. The stop permits the valve to be locked in the open position. The valve returns to automatic position when the valve is energized.

Normally Closed Models

With the manual opener set to AUTO and the powerhead energized, the valve is opened as shown in Fig. 36A. When the powerhead is de-energized, a spring-return mechanism drives the valve to the closed position as shown in Fig. 36B. The valve can also be opened with no electrical power by moving the manual opening lever over the stop and pushing slowly and firmly to the MAN. OPEN position. The stop permits the valve to be locked in the open position. The valve returns to the automatic position when the valve is energized. Auxiliary switch is not energized when the valve is manually opened.

Normally Open Models

When the powerhead is de-energized, a spring-return mechanism drives the valve to the open position (Fig. 36A). When energized, the valve is closed as shown in Fig. 36B. A reverse-acting thermostat is required to control a normally open valve.

NOTE: Inlet Port is stamped A and Outlet Port is stamped B on the valve body.

Checkout

1. Raise the setpoint on the zone thermostat above the room temperature to initiate a call for heat.
2. Observe all control devices—the valve should open and the auxiliary switch should make the circuit to the circulator or other valve at the end of the opening stroke.
3. Lower the setpoint on the zone thermostat below the room temperature.
4. Observe the control devices. The valve should close and the auxiliary equipment should stop.

Service

This valve should be serviced by a trained, experienced service technician.

1. If the valve is leaking, drain the system and check to see if the O-ring needs replacing.
2. If the gear train is damaged, replace the entire powerhead assembly. See the Installation section. If the motor is burned out, replace the motor.

NOTE: Resideo zone valves are designed and tested for silent operation in properly designed and installed systems; however, water noises can occur as a result of excessive water velocity or piping noises can occur in high temperature (higher than 212°F(100°C) systems with insufficient water pressure.



Resideo Singapore Pte.Ltd
#04-01, 1 Paya Lebar Link

Paya Lebar Quarter 1
Singapore 408533

Subject to change without notice.